

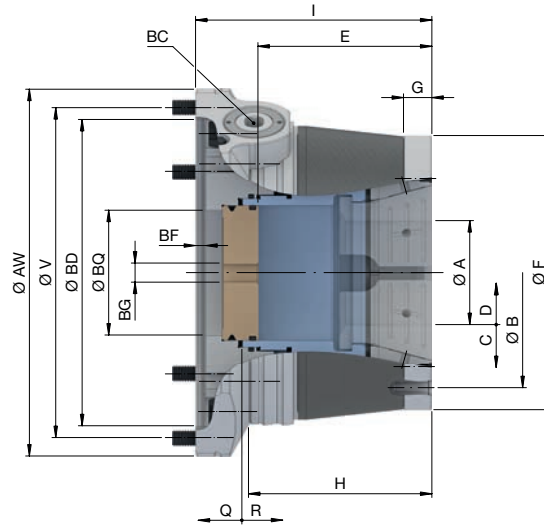

**TOROK CFK SE.** Technical data



Product line	<b>SE</b>		
Size	<b>52</b>	<b>65</b>	
Run-out ≤ [mm]	0,015		
Max. radial clamping force [kN]	108	120	
Max. axial drawtube force [pull / push] [kN]	40	45	
Flange location	BD	Ø 145 H7	Ø 162 H7
Flange fit length [mm]	BF	5,1	
Max. actuating torque [Nm]	BC	75	90
RPM n max. [1/min.]	7000		
Clamping range [mm]	A	3 – 52	3 – 65
Release stroke in Ø [mm]	C	0,6	
Reserve stroke in Ø [mm]	D	1	
Range / recommended workpiece tolerance [mm]	± 0,5		
End-stop depth [mm]	E	90	92
Ø Capacity [mm]	BQ	53	66
End-stop thread size [M]	BG	10	12
Location front end-stop	F	Ø 125 f7	Ø 145 f7
Length [mm]	H	92	97
Centering length [mm]	G	15	
Bolt hole circle end-stop	B	LK Ø 107 [3 x M6]	LK Ø 126 [3 x M6]
Total length [mm]	I	120	125
Reserve stroke axial [mm]	Q	2	
Release stroke axial [mm]	R	2,5	
Bolt hole circle	V	LK Ø 156 [6 x M8]	LK Ø 176 [6 x M8]
Outer Ø [mm]	AW	174	194
Weight [kg]		7	10,3
In stock		-	-
Material no.		10000486	10000487



Clamping heads Page 422	Adaptations I.D. clamping Page 270	Adaptations jaw clamping Page 316	Face driver / morse taper Page 324	Magnet module Page 332	Flanges Page 131	Accessory overview Page 478



**TOROK CFK RD.** Technical data

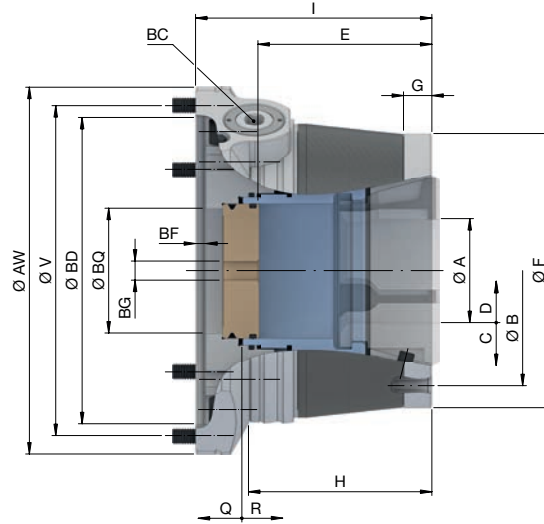

Product line	<b>RD</b>	
Size	<b>52</b>	<b>65</b>
Run-out ≤ [mm]		0,010
Max. radial clamping force [kN]	94	105
Max. axial drawtube force [pull / push] [kN]	40	45
Flange location	BD	Ø 145 H7
Flange fit length [mm]	BF	5,1
Max. actuating torque [Nm]	BC	75
RPM n max. [1/min.]		7000
Clamping range [mm]	A	3 – 52
Release stroke in Ø [mm]	C	0,6
Reserve stroke in Ø [mm]	D	1
Range / recommended workpiece tolerance [mm]		± 0,5
End-stop depth [mm]	E	90
Ø Capacity [mm]	BQ	53
End-stop thread size [M]	BG	10
Location front end-stop	F	Ø 125 f7
Length [mm]	H	92
Centering length [mm]	G	15
Bolt hole circle end-stop	B	LK Ø 107 [3 x M6]
Total length [mm]	I	120
Reserve stroke axial [mm]	Q	2
Release stroke axial [mm]	R	2,5
Bolt hole circle	V	LK Ø 156 [6 x M8]
Outer Ø [mm]	AW	174
Weight [kg]		7,3
In stock		-
Material no.		10000488
		10000489



Clamping heads Page 430	Adaptations I.D. clamping Page 270	Adaptations jaw clamping Page 316	Face driver / morse taper Page 324	Magnet module Page 332	Flanges Page 131	Accessory overview Page 478