

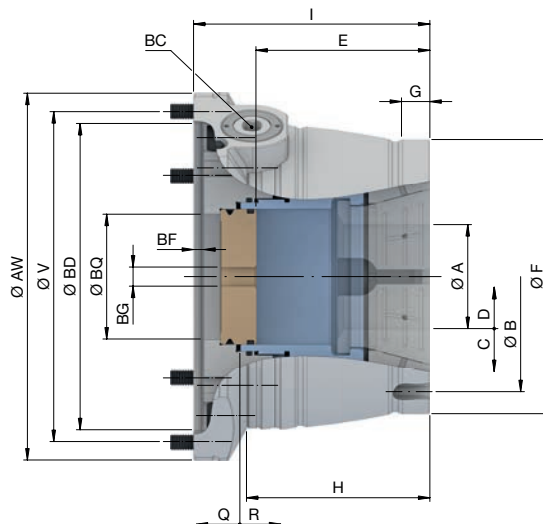

TOROK SE. Technical data



Product line	SE			
Size	52	65	100	
Run-out ≤ [mm]		0,015		
Max. radial clamping force [kN]	108	120	150	
Max. axial drawtube force [pull / push] [kN]	40	45	65	
Flange location	BD	Ø 145 H7	Ø 162 H7	Ø 240 H6
Flange fit length [mm]	BF	5,1		5
Max. actuating torque [Nm]	BC	75	90	
RPM n max. [1/min.]		7000	6000	5000
Clamping range [mm]	A	3 – 52	3 – 65	15 – 100
Release stroke in Ø [mm]	C		0,6	2
Reserve stroke in Ø [mm]	D		2	1,5
Range / recommended workpiece tolerance [mm]		± 0,5		± 1,0
End-stop depth [mm]	E	90		92
Ø Capacity [mm]	BQ	53	66	100
End-stop thread size [M]	BG	10	12	
Location front end-stop	F	Ø 125 f7	Ø 145 f7	Ø 195 f7
Length [mm]	H	92	97	67
Centering length [mm]	G	17	14	15
Bolt hole circle end-stop	B	LK Ø 107 [3 x M6]	LK Ø 126 [3 x M6]	LK Ø 180 [3 x M8]
Total length [mm]	I	120	125	130
Reserve stroke axial [mm]	Q		2	3,1
Release stroke axial [mm]	R		2,5	5
Bolt hole circle	V	LK Ø 156 [6 x M8]	LK Ø 176 [6 x M8]	LK Ø 235 [6 x M10]
Outer Ø [mm]	AW	174	194	260
Weight [kg]		12,6	15,2	32
In stock		✓	✓	✓
Material no.	10000174	10000175	10015275	

The bolt hole circle does not have equal division.

Clamping heads Page 422	Adaptations I.D. clamping Page 270	Adaptations jaw clamping Page 316	Face driver / morse taper Page 324	Magnet module Page 332	Flanges Page 131	Clamping head adapter Page 513	Accessory overview Page 478



TOROK RD. Technical data

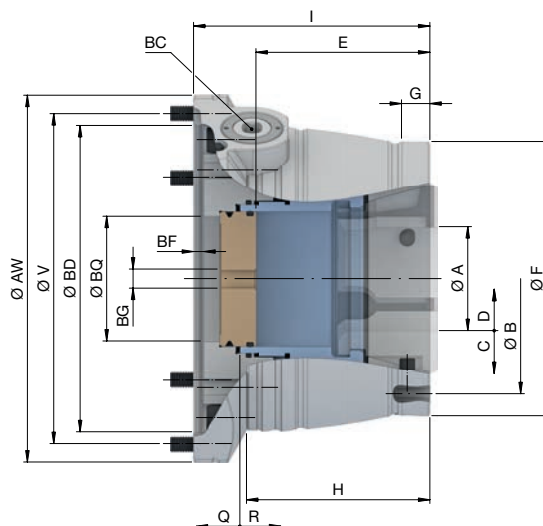

Product line	RD			
Size	52	65	80	100
Run-out ≤ [mm]	0,010		0,015	
Max. radial clamping force [kN]	94	105	115	150
Max. axial drawtube force [pull / push] [kN]	40	45	50	65
Flange location	BD	Ø 145 H7	Ø 162 H7	Ø 240 H6
Flange fit length [mm]	BF	5,1		5
Max. actuating torque [Nm]	BC	75	90	70
RPM n max. [1/min.]		7000	6000	5500
Clamping range [mm]	A	3 – 52	3 – 65	4 – 80
Release stroke in Ø [mm]	C	0,6		2
Reserve stroke in Ø [mm]	D	1		1,5
Range / recommended workpiece tolerance [mm]		± 0,5		± 1,0
End-stop depth [mm]	E	90	92	90
Ø Capacity [mm]	BQ	53	66	80
End-stop thread size [M]	BG	10		12
Location front end-stop	F	Ø 125 f7	Ø 145 f7	Ø 160 f7
Length [mm]	H	92	97	57
Centering length [mm]	G	17		15
Bolt hole circle end-stop	B	LK Ø 107 [3 x M6]	LK Ø 126 [3 x M6]	LK Ø 139 [3 x M6]
Total length [mm]	I	120	125	
Reserve stroke axial [mm]	Q	2		2,1
Release stroke axial [mm]	R	2,5		5
Bolt hole circle	V	LK Ø 156 [6 x M8]	LK Ø 176 [6 x M8]	LK Ø 235 [6 x M10]
Outer Ø [mm]	AW	174	194	260
Weight [kg]		12,6	15,2	32
In stock		✓	✓	✓
Material no.		10000172	10000173	10015262

The bolt hole circle does not have equal division.

Clamping heads Page 430	Adaptations I.D. clamping Page 270	Adaptations jaw clamping Page 316	Face driver / morse taper Page 324	Magnet module Page 332	Flanges Page 131	Clamping head adapter Page 513	Accessory overview Page 478