

TRAUB

TOPlus mini chuck for TRAUB

Size	Variant	Machine type	Ø Capacity [mm]	Spindle nose	Connecting thread outside	In stock	Order no.
40	Deadlength	TNL32 GSP	33	A2-4	M42 x 1,5 - LH	✓	10653/0003

Machine spindle standard DIN ISO 702-1.

SPANNTOP mini chuck for TRAUB

Size	Variant	Machine type	Ø Capacity [mm]	Spindle nose	Connecting thread inside	In stock	Order no.
42	Deadlength	TNK42 GSP / TNK65 GSP / ABC65	44	AP100	M62 x 1,5	✓	10686/0001
52	Deadlength	TNK42 GSP / TNK65 GSP / ABC65	54	AP100	M62 x 1,5	✓	10686/0002

Machine spindle standard DIN ISO 702-1.

SPANNTOP nova chuck for TRAUB

Size	Variant	Machine type	Ø Capacity [mm]	Spindle nose	Connecting thread inside	In stock	Order no.
65	Modular	TNX 65/42	67	A2-6	M75 x 1,5	-	2711/0001

Machine spindle standard DIN 55026.

SPANNTOP chuck for TRAUB

Size	Variant	Machine type	Ø Capacity [mm]	Spindle nose	Connecting thread outside	Connecting thread inside	In stock	Order no.
36	Combi deadlength	TNK36 GS	36	A2-4	M42 x 1,5		-	2613/0016
42	Combi deadlength	TNC 42	46	A2-5		M54 x 1,5	-	2613/0003
65	Combi deadlength	TNC 65 / TNX 65-D65	67	A2-6	M74 x 1,5		✓	2613/0004
	Modular	TNA 300/400-65 / TND350/G / TND 400 / TNS 65				M74 x 1,5		-

Machine spindle standard DIN 55026.

CHUCKS

Machine specific chucks

TRAUB TNK26/32. Machine specific chucks incl. accessories - main spindle

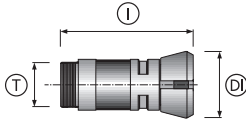
							
Product	Profile	Clamping range [mm] A	Head Ø [mm] DI	Connecting thread outside T	Total length [mm] I	In stock	Order no.
Basic body			69,7	M42 x 1,5 - LH	132,3	✓	1105/0005
Clamping head ZW	●	4 – 36	69,7			✓	sk6970zwr4,0-36,0
	■	7 – 9				-	sk6970zvw7,0-9,0
		10 – 24				-	sk6970zvw10,0-24,0
	⬡	7 – 9				✓	sk6970zws7,0-9,0
10 – 30		✓	sk6970zws10,0-30,0				
Manual changing fixture						✓	mq32
Assembling aid						✓	eaw36tnk

TRAUB TNK26/32. Machine specific chucks incl. accessories - sub spindle

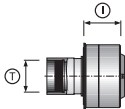
							
Product	Profile	Clamping range [mm] A	Head Ø [mm] DI	Connecting thread outside T	Total length [mm] I	In stock	Order no.
Machine specific SPANNTOP chucks				M42 x 1,5	90	-	2613/0016
Clamping head ZWG	●	4 – 36	69,7			✓	sk6970zwr4,0-36,0
	■	7 – 9				-	sk6970zvgv7,0-9,0
		10 – 24				-	sk6970zvgv10,0-24,0
	⬡	7 – 9				-	sk6970zws7,0-9,0
10 – 30		-	sk6970zws10,0-30,0				

TRAUB TNK26/32

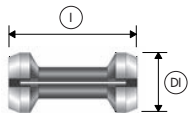
							
Product	Profile	Clamping range [mm] A	Head Ø [mm] DI	Total length [mm] I	In stock	Order no.	
Segmented collet	●	5 – 32	42	90	✓	sb.d/0001r5,0-32,0	
	■	8 – 22			-	sb.d/0001v8,0-22,0	
	⬡	8 – 27			-	sb.d/0001s8,0-27,0	