

# STATIONARY CLAMPING DEVICES

## InoFlex centric clamping vise

### InoFlex VF centric clamping vise. Technical data

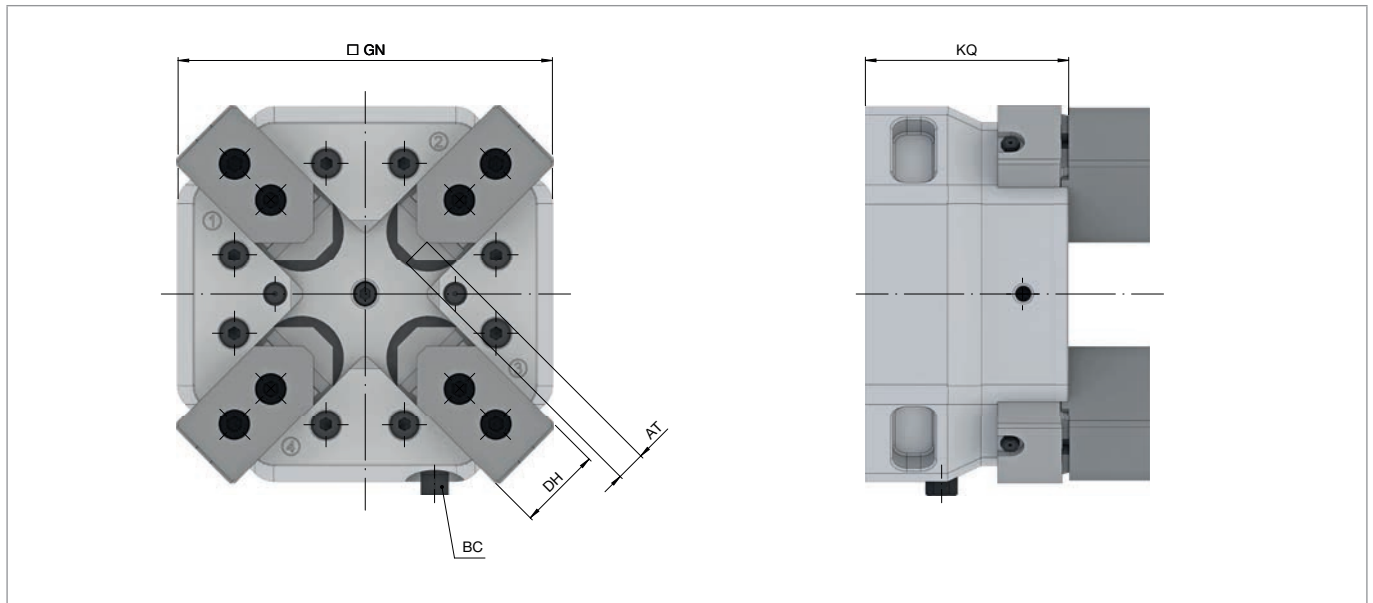

Size	160	260
Variant	VF	
Repeatability $\leq$ [mm]	0,020	
Max. radial clamping force [kN]	40	70
Max. actuating torque [Nm]	100	180
RPM n max. [1/min.]	400	
Stroke per jaw [mm]	12,6	14
Compensating stroke for each jaw [mm]	11,6	13,0
Height without jaws [mm]	88,0	125,5
Jaw width [mm]	36	48
Outer dimension [mm]	162	235
Weight [kg]	13	44,5
In stock	✓	✓
Material no.	10015010	10015012

The run-out is based on soft, milled top jaws.



#### Scope of delivery

- Centric clamping vise
- Top jaws, soft
- Grease cartridge
- Actuation wrench