

Operating instructions

[incl. installation manual]

Changing part

EN

Translation of the original operating instructions

Contents

1	General.....	6
1.1	Information about this manual.....	6
1.2	Key to symbols.....	6
1.3	Definition of terms.....	7
1.3.1	Release setting.....	7
1.3.2	Complete clamping reserve.....	8
1.4	Limitation of liability.....	8
1.5	Copyright.....	8
1.6	Scope of delivery.....	8
1.7	Spare parts and accessories.....	9
1.8	Warranty terms.....	9
2	Safety.....	10
2.1	Responsibility of the operator.....	10
2.2	Personnel requirements.....	10
2.3	Intended use.....	12
2.4	Personal protective equipment.....	14
2.5	Particular hazards.....	15
2.6	Other safety instructions.....	16
2.7	Screws.....	18
2.8	Functionality.....	18
2.9	Environmental protection.....	19
3	Technical data.....	20
3.1	General information.....	20
3.2	Performance values.....	20
3.3	Speed.....	20
3.4	Operating conditions.....	20
3.5	Type designation.....	21
4	Layout and function.....	22
4.1	Brief description.....	22
4.2	Optional accessories.....	22
4.2.1	Clamping devices.....	22
5	Use.....	23
6	Transport, packaging, storage.....	24
6.1	Safety, transport, packaging, storage.....	24
6.2	Symbols on the packaging.....	25
6.3	Transport inspection.....	25
6.4	Unpacking and internal transportation.....	26
6.5	Packaging.....	26
6.6	Storage.....	27
6.7	Preservation.....	27
6.8	Return to storage.....	27

7	Installation	28
7.1	Installation safety	28
7.2	Preliminary remarks	29
7.3	Screw tightening torques.....	31
7.4	Preparation of machine for installation	32
7.5	Installation of the product	32
7.5.1	Compatibility check.....	32
7.5.2	Preparation of the product	32
7.5.3	Installation of the product on the clamping device	32
8	Commissioning	33
8.1	Commissioning safety	33
8.2	Tests	34
8.3	Procedure after a collision.....	35
9	Removal	36
9.1	Safe removal.....	36
9.2	Preparing the machine for removal	38
9.3	Removal of the product	38
9.3.1	Removal of the product from the clamping device.....	38
9.4	Removal of the product	38
9.4.1	Disassembly of the cover variant / axially screwed centrally	39
9.4.2	Disassembly of the variant x-times with axial screw connection..	40
9.4.3	Disassembly of the radially screwed variant	41
9.4.4	Removal of the axial retaining ring variant.....	42
10	Maintenance	43
10.1	Maintenance safety.....	43
10.2	Maintenance schedule	43
10.3	Cleaning.....	44
10.4	Visual inspection	45
10.5	Use of lubricants	46
11	Disposal.....	47
12	Faults.....	48
12.1	Procedure with faults.....	48
12.2	Fault table	49
12.3	Commissioning after a fault has been remedied	49
13	Annex	50
13.1	Contact.....	50
13.2	Manufacturer certification.....	50

Directory of tables

Table 1:	Operating conditions	20
Table 2:	Screw tightening torques, metric control threads.....	31
Table 3:	Screw tightening torques for aluminum components.....	32
Table 4:	Maintenance table	43
Table 5:	Selection of lubricants	46
Table 6:	Fault table.....	49

1 General

1.1 Information about this manual

This manual enables you to work safely and efficiently with the product.

This manual is part of the product and must be kept in a location directly beside the product that is accessible to the personnel at all times. The personnel must have read this manual carefully and understood its contents before starting any work. The basic requirement for safe work is compliance with all stipulated safety notices and work-related instructions in this manual.

If the product is passed onto a third party, this manual must accompany it.

Illustrations in this manual are there to facilitate a basic understanding, and may differ from the actual design configuration of the product.



WARNING

Serious injuries caused by individual products or by inappropriate combinations of them!

- Read and pay attention to all operating instructions for individual products and combinations of them.

This manual is for products such as:

- Sprung workpiece end-stop
- Sprung depth end-stop
- Sprung swarf bell housing
- Sprung ejector
- Sprung centering tip
- Sprung vibration damper

1.2 Key to symbols

Safety instructions in this manual are designated by symbols. The safety notices are invoked by signal words that express the level of hazard involved.

Always comply with safety notices and exercise caution to avoid accidents, injury to people and damage to materials.

Safety notices



DANGER

... indicates an immediate and hazardous situation that can lead to death or serious injury if not avoided.



WARNING

... indicates a potentially hazardous situation that can lead to death or serious injury if not avoided.

Tips and recommendations



CAUTION

... indicates a potentially hazardous situation that can lead to moderate or slight injuries if not avoided.



NOTE

... indicates a potentially hazardous situation that can lead to damage to materials if not avoided.



INFORMATION

... highlights useful tips and recommendations as well as information for efficient and problem-free operation.



... refers to other documents relating to personal and general safety.

Warning symbols may appear on the product or its components.

Always pay attention to warning symbols, and exercise caution to avoid accidents, injury to people and damage to materials.

... warns of stored energy [for example involving springs].



... warns of hand injuries.



... draws attention to the fact that the operating instructions of the product must be read.



1.3 Definition of terms

1.3.1 Release setting

Release setting means that the clamping device is released. If the clamping device is released, this also releases the workpiece.

1.3.2 Complete clamping reserve

Complete clamping reserve means that the clamping device is clamped without a workpiece. The complete stroke has been used up, which means that the clamping device is therefore at the limit position for clamping reserve.

1.4 Limitation of liability

All details and notices in this manual were compiled with due reference to applicable standards and specifications, state-of-the-art technology and our many years of expertise and experience.

The manufacturer accepts no liability for damage arising from any of the following:

- Non-compliance with this manual
- Unintended use
- Use of untrained personnel
- Autonomous conversion work
- Technical modifications
- Use of non-approved spare parts
- Use of non-approved accessories

Subject to any commitments agreed to in the supplier contract, the General Terms & Conditions of Business and the delivery terms of the manufacturer and all legislative stipulations valid at the time of conclusion of this contract.

1.5 Copyright

This manual is protected by copyright, and are only intended for internal use.

The dissemination of this manual to third parties, reproductions in any shape or form - even in part - as well as commercial use and/or communication of their contents are prohibited for anything other than internal use, except with the written consent of the manufacturer.

Infringements oblige the offending party to pay compensation. Without restriction on further claims.

1.6 Scope of delivery

The scope of delivery of this product includes:

- Changing part
- The operating instructions

Additionally needed and included as optional items in the scope of delivery:

- Basic clamping device

1.7 Spare parts and accessories



WARNING

Serious injuries can be caused by incorrect or defective spare parts!

- Always use genuine spare parts made by the original manufacturer.



NOTE

Damage, malfunctions or total failure of the product or the machine tool caused by an incorrect or defective spare parts!

- Always use genuine spare parts made by the original manufacturer.

Spare parts and accessories can be sourced from contract dealers or directly from the manufacturer [see »Contacts« chapter].

Without exception, wearing parts and components in contact with the workpiece are not covered by warranty.

1.8 Warranty terms

The warranty terms are included in the manufacturer's General Terms & Conditions of Business.

2 Safety

This section provides an overview of all the important safety aspects for optimum protection of personnel, and for safe and problem-free operation.

2.1 Responsibility of the operator

The product is used in the industrial sector. The operator of the product is therefore governed by the provisions of Health & Safety at Work legislation.

As well as the safety notices in this manual, the area of use of the product must also comply with locally applicable safety, accident prevention and environmental protection specifications as well as those in the manual for the machine tool.

No modifications must be made to the product. The operator is wholly and solely responsible for any resultant personal injury and/or damage to materials.



DANGER

Serious injuries caused by parts being ejected centrifugally due to a drop in actuating force / supply pressure!

- On the machine, ensure that the actuating force / the supply pressure do not drop while the product is in use.
- If no precautions have been taken on the machine to maintain the actuating force / the supply pressure, it is prohibited to use this product on the machine.
- Pay attention to the operating instructions for the machine tool.

2.2 Personnel requirements



WARNING

Serious injuries caused by incorrect handling of the product by insufficiently skilled or trained personnel!

- All activities must be performed by skilled staff from the relevant specialist field.



WARNING

Serious injuries caused by unauthorized presence of unauthorized personnel in the working area!

- Keep unauthorized people away from the working area.
- If in doubt, speak to people and direct them to leave the working area.
- Interrupt work until unauthorized people have left the working area.



NOTE

Serious damage to materials caused by incorrect handling of the product by insufficiently skilled or trained personnel!

- All activities must be performed by skilled staff from the relevant specialist field.

This manual name the following skills sets required for various different areas of activity:

Skilled specialist

Skilled specialists, due to their professional training, knowledge and experience and awareness of applicable provisions, are capable of carrying out the work entrusted to them and independently to identify and avoid potential hazards.

Hydraulics specialist

Hydraulics specialists are trained in the specific task profile for which they are employed, and are familiar with the relevant standards and legislative provisions.

Due to their vocational training and experience, hydraulics specialists can work on hydraulic systems and can independently identify and avoid potential hazards.

Pneumatics specialist

Pneumatics specialists are trained in the specific task profile for which they are employed, and are familiar with the relevant standards and legislative provisions.

Due to their vocational training and experience, pneumatics specialists can work on pneumatic systems and can independently identify and avoid potential hazards.

Electricians

Electricians are trained in the specific task profile for which they are employed, and are familiar with the relevant standards and legislative provisions.

Due to their vocational training and experience, electricians can work on electrical systems and can independently identify and avoid potential hazards.

Trainees

Trainees can only work on the machine under the supervision and direction of staff skilled in the relevant specialist field.

The only people admitted as personnel are those who can reasonably be expected to carry out their work to a reliable standard. People whose response capabilities are impaired, for example by drugs, alcohol or medication, are prohibited.

For the selection of personnel, pay attention to the stipulations applicable at the place of work governing age and specific vocational requirements.

2.3 Intended use

The product is only intended for installation in a CE-compliant machine tool with a separating set of guards.

This product is intended for installation in a compatible product with corresponding attachment geometry.

The product is only intended for the type of use described in this manual [see »Use« chapter]. Furthermore, an extended form of use can be agreed contractually between manufacturer and operator.

Only skilled staff from the appropriate specialist fields may install, operate, maintain and clean the product [see »Personnel requirements« chapter].

Never exceed the technical values stipulated for the product [see »General information« and »Operating conditions« chapters].

Maintain the product at regular intervals [see »Maintenance schedule« chapter].

When used for its intended purpose, the operational safety of the product is assured, subject to compliance with relevant safety stipulations, to the full extent foreseeable.

Intended use also includes compliance with all stipulations in this manual.

Any form of use beyond the scope of intended use, or other forms of use of the product, is considered as misuse, and can lead to dangerous situations.



WARNING

Serious injuries caused by misuse of the product!

- Only use in CE-compliant machine tool with a separating guard.
- Only use with compatible products.
- Only use for the disclosed purpose [see »Use« chapter].
- Product only to be used by trained specialists in the relevant field [see »Personnel requirements« chapter].
- Never exceed the technical data indicated on the product [see »General details« and »Operating conditions« chapters].
- The product requires regular maintenance [see the »Maintenance schedule« chapter].
- Only use with approved attachments and/or clamping elements.



NOTE

Material damage caused by misuse of the product!

- Only use in CE-compliant machine tool with a separating guard.
- Only use with compatible products.
- Only use for the disclosed purpose [see »Use« chapter].
- Product only to be used by trained specialists in the relevant field [see »Personnel requirements« chapter].
- Never exceed the technical data indicated on the product [see »General details« and »Operating conditions« chapters].
- The product requires regular maintenance [see the »Maintenance schedule« chapter].
- Only use with approved attachments and/or clamping elements.

Claims of all kinds will be rejected that are due to unintended use.

Here are some examples of unintended use of the product

- If people fail to observe the safety stipulations when working on the product, and failing to use additional protective equipment, for example to machine clamped workpieces.
- If the product is used on non-intended machines and/or clamping devices.

2.4 Personal protective equipment

During work, it is essential to wear personal protective equipment to minimize the health hazards.

Always wear the required personal protective equipment when working on any given job.

Always pay attention to any notices about personal protective equipment displayed in the working area.

Always wear



Workplace clothing

Workplace clothing should be close-fitting, with low tear-resistance, narrow cuffs and no protruding parts. It serves primarily to protect the wearer from coming into contact with moving machine parts. Do not wear rings, chains or other jewelry.



Safety footwear

To protect the wearer from any heavy items that may fall, and from losing their footing on slippery ground.



Protective goggles

To protect the eyes from projectile parts and liquid splashes.



Hair net

To protect long hair from getting snagged in rotating parts on the machine tool.

Additional personal protective equipment

When carrying out certain work, additional personal protective equipment is required. Separate reference is made to this in the individual chapters of this manual. The following section explains these additional items of personal protective equipment:



Protective gloves

To protect the hands from friction, chafing, stabbing or deeper injuries and from contact with hot surfaces.



Hard hat

To protect against falling and projectile parts and materials.

2.5 Particular hazards

The following section names residual risks resulting from the installation of the product in a machine tool. In all cases, the residual risks detected during a risk assessment of the machine tool need to be named by the operator.

Pay attention to the safety instructions named here, as well as the warning notices in other chapters of these operating instructions to reduce the risk of health hazards and to prevent dangerous situations.

Moving parts



WARNING

Serious injuries caused by touching rotating and/or moving parts!

- Do not open guards while the system is operating.
- During operation, do not reach for rotating and/or moving parts.
- Pay attention to the gap dimensions of moving parts.
- Before opening the guards, ensure that none of the parts are moving any more.

Sharp-edged parts



WARNING

Serious cut injuries caused by sharp-edged parts and burrs!

- All installation of individual parts must be performed by skilled staff from the relevant specialist field.
- Also wear the following items of personal protective equipment, in addition to the basic equipment:



2.6 Other safety instructions



DANGER

Serious injuries caused by workpieces being ejected centrifugally when clamping unit is released while still rotating!

- Never release the clamping of the workpiece while it is still rotating.



WARNING

Serious injuries caused by the release of stored energy!

- Do not open the screws secured with sealing lacquer.
- When unfastening the relevant screws, these must be actuated crosswise in alternating fashion to reduce clamping action to a minimum.



WARNING

Serious head injuries caused by bending into the working area of the machine!

- Only ever bend into the working area of the machine if there are no cutting tools or sharp objects in it, or if these are covered.
- Never move body parts under parts in the working area of the machine with the potential to drop down.



WARNING

Serious injuries caused by snagging body parts on the rotating machine spindle!

- Never reach into the product while the machine spindle is still rotating.
- Before working on the product, ensure that the machine spindle is unable to start up.



WARNING

Serious injuries caused by reaching into slots and bores!

- Never reach into slots or bores.



WARNING

Serious injuries caused by workpieces dropping or the clamping unit getting released!

- Only unclamp the workpiece if it is protected against falling.



WARNING

Serious injuries caused by the use of damaged products or by their components and accessories!

- Check products or their components and accessories on a regular basis for visible signs of damage [see »Inspections« and »Cleaning« chapters].
- Use of damaged products, their damaged components and/or their damaged accessories is prohibited.
- Report damage to the operator immediately.
- Damaged components / accessories must be replaced with genuine spare parts / accessories made by the manufacturer.



CAUTION

Cut injuries caused by sharp edges and burrs resulting from wear and/or repeated rework!

- Remove sharp edges and burrs.
- If necessary, replace worn components with genuine parts made by the manufacturer.



NOTE

Serious damage to materials / the machine tool / the product caused by workpieces being ejected centrifugally if clamping is released while they are still rotating!

- Never release the clamping of the workpiece while it is still rotating.



NOTE

Damage to materials caused by untightening the wrong screws!

- Do not open the screws secured with sealing lacquer.

2.7 Screws



WARNING

Serious injuries caused by radially installed screws being ejected centrifugally if installed incorrectly / poor handling!

- Do not open the screws secured with sealing lacquer.
- Screws and threaded pins fitted radially to the product that were bonded with adhesive need to be secured again using a standard, medium-strength screw adhesive and tightened to the specified tightening torque [see marking or the »Screw tightening torques« chapter]. Before reinstallation, clean and degrease the screw and internal thread.
- Radially mounted screws and threaded pins that were not bonded with sealing lacquer or an adhesive need to be tightened back down to the specified tightening torque [see nomenclature or the »Screw tightening torques« chapter].
- If in doubt, contact the manufacturer immediately to determine how best to proceed.

2.8 Functionality



WARNING

Serious injuries caused by severe contamination of the product!

- Always comply with the cleaning instructions and intervals [see »Cleaning« chapter].

2.9 Environmental protection



NOTE

Substantial damage to the environment can result from non-compliant handling or incorrect disposal of environmentally hazardous substances!

- If environmentally hazardous substances enter the environment accidentally, take immediate remedial action.
- If in doubt, notify the relevant municipal authorities about the incident.

The following environmentally hazardous substances are used:

Lubricants, auxiliary materials and operating fluids

Lubricants such as grease and oil can contain toxic substances. These must not enter the environment.

Dispose of environmentally hazardous substances properly [see »Disposal« chapter].

3 Technical data

3.1 General information

The product is available in various sizes and variants, with each version differing in terms of dimensions and weight.

3.2 Performance values



NOTE

Material damage to the products use and/or to the machine tool caused by exceeding the maximum performance values!

- Do not exceed the maximum performance values [see »General information« chapter].
- On all products used, do not exceed the lowest of the maximum performance values.
- Only use product in machine tools with the same performance values.



INFORMATION

Details of maximum performance values can be found on each product.

If, due to abrasive wear, those performance values are no long legible, refer to the operating instructions.

3.3 Speed

The product is authorized for rotational operation.



DANGER

Serious injuries caused by parts being ejected centrifugally due to a non-compliant combination of several products!

- From all of the maximum speeds indicated for the combined products, always remain at the lowest of those maximum speeds.

3.4 Operating conditions

Indication	Value	Unit
Ambient temperature range	15 - 65	°C
Workpiece temperature	≤ 80	°C
Humidity	≤ 80	%

Table 1: Operating conditions

3.5 Type designation

The type designation is on the product and it includes the following indications:

- ID number [marked with a # symbol]

4 Layout and function

4.1 Brief description

The changing part is a sprung module equipped with springs. The changing part acts as a workpiece end-stop, a depth end-stop, a swarf bell housing, an ejector, a centering tip or a vibration damper for HAINBUCH clamping devices.

4.2 Optional accessories

4.2.1 Clamping devices

The clamping device is secured to the product to adapt it to the machine tool.

5 Use

The product can only be used in conjunction with a suitable product from HAINBUCH.

As well as for its general field of application, this product was designed and developed for use, when necessary, in a specific and documented application [see clamping situation drawing or order confirmation].

Any other fields of application require the explicit approval of the manufacturer.

6 Transport, packaging, storage

6.1 Safety, transport, packaging, storage



WARNING

High level of physical strain due to the weight of the product or of its components if not transported properly!

- From a weight of 10 kg, use appropriate transport equipment, lifting gear and lifting tackle.



WARNING

Serious crushing injuries and breakages caused by falling parts if transported incorrectly!

- Ensure that the product cannot roll away or fall.
- Place on a non-slip surface.
- When using lifting gear, use appropriate load-bearing equipment and lifting tackle.



WARNING

Serious injuries caused by transporting off-center equipment!

- Pay attention to marks on the packaging items.
- Attach the crane hook directly above the center of gravity.
- Raise carefully and correct the lifting points if necessary.



WARNING

Serious injuries caused by incorrect transport with lifting gear!

- Never raise loads above people.
- Never step under suspended loads.
- Pay attention to information about the intended lifting points. Ensure that the lifting gear is mounted on a secure base.
- Only use authorized and undamaged lifting gear, load-bearing equipment and lifting tackle.
- Never exceed the maximum load-bearing capacity of lifting gear, load-bearing equipment and lifting tackle.



NOTE

Damage to materials caused by falling parts if transported incorrectly!

- Ensure that the product cannot roll away or fall.
- Place on a non-slip surface.
- When using lifting gear, use appropriate load-bearing equipment and lifting tackle.

6.2 Symbols on the packaging



Fragile

Designates packaging items with fragile or breakable contents.

Handle the packaging item with care. Do not drop it and protect it against collision impacts.



Keep it dry

Keep packaging items dry and protect them from the ingress of water.



Position designation

Points to the correct upright position of the packaging item.

6.3 Transport inspection

Check the delivery on receipt immediately to ensure it is complete and has not been damaged in transit.

Proceed as follows if you find any externally visible signs of damage while in transit:

- Refuse to accept the delivery, or only subject to later approval
- Make a note of the extent of damage on the transportation documents or on the delivery note of the transportation company
- Initiate a complaint



INFORMATION

Raise a complaint for every defect as soon as it is discovered. Compensation claims can only be enforced during the applicable complaint periods.

6.4 Unpacking and internal transportation

The total weight of the product depends on its size.

Depending on the weight involved, it may be necessary to use lifting gear to lift the product or its components out of the packaging safely, to transport them and to position and install them in the machine tool or on the machine table.

1. The product is packaged in a stable position, and it has threads / bores for transportation.
2. Lifting tackle can be installed in these transportation threads / bores. To lift the product out of its packaging, the front-end functional threads can if necessary be used to attach lifting tackle to upright packaged products.
3. Attach load-bearing equipment to the lifting tackle.
4. Subject to weight, use lifting gear to lift the product out of its packaging safely, and place it down on a stable, flat surface.
5. Secure the product to prevent it from rolling away.
6. When transporting on a trolley or car, ensure that the product is securely mounted on a non-slip surface before starting to move it.

6.5 Packaging

The individual packaging items are packaged in an appropriate manner for the type of transportation involved. Always use environmentally compatible materials for packaging purposes.

Packaging should protect individual components from damage in transit, corrosion and other forms of damage, up until installation. For this reason, do not destroy the packaging, and do not remove it until shortly before installation.



INFORMATION

The packaging units are packaged, wrapped in airtight film and placed in cardboard boxes. On the individual weights of each of the sizes [see »General information« chapter].

Dispose of packaging material in accordance with applicable legislative provisions and local regulations.



NOTE

Damage to the environment caused by improper disposal of packaging materials!

- Dispose of packaging materials in an environmentally responsible manner.
- Pay attention to local disposal regulations and, if necessary, appoint a specialist waste disposal company with this work.

6.6 Storage



INFORMATION

The packaged items may display information relating to storage and readmission to storage that extend beyond the scope of these requirements. Pay attention to these notices.

Store packaged items under the following conditions:

- Safe for storage.
- Do not store outdoors.
- Store in a dry, dust-free place.
- Avoid exposure to aggressive media.
- Protect against direct sunlight.
- Avoid mechanical vibration.
- Storage temperature: 15 to 35°C.
- Relative humidity: Maximum 60%.
- In the event of storage for more than 3 months:
 - On a regular basis, check the general condition of all parts and packaging.
 - If necessary, refresh the preservation or replace it.

6.7 Preservation

1. Clean the product [see »Cleaning« chapter].
2. Apply a light coating of preserving oil to the inner and outer faces of the product. Wipe away surplus preserving oil with a soft, lint-free, tear-resistant cloth.
3. Pack product air-tight in foil.
4. Return product to storage [see »Return to storage« chapter].

6.8 Return to storage

Return product to storage under the following conditions:

1. Preserve the product [see »Preservation« chapter].
2. The product must be stored in a safe condition. Use an appropriate container for the product, on a non-slip surface, or fit the floor of the shelving unit with an all-round safety border.
3. For storage conditions, see the »Storage« chapter.

7 Installation

7.1 Installation safety



WARNING

Serious injuries caused by unskilled staff during installation / removal!

- Installation and removal must be performed by skilled staff from the relevant specialist field.



WARNING

Serious injuries can be caused if the machine tool starts up accidentally!

- Set the machine tool into set-up mode.
- Remove all tools, auxiliary equipment and items of test equipment immediately from the working area of the machine.
- Remove all lifting gear from the product and from the working area of the machine.



WARNING

Serious injuries caused by the escape of media under high pressure!

- Shut down media delivery during installation and removal.
- Relieve any pressure trapped in the system.
- Shut down the system.



WARNING

Serious crushing injuries and breakages caused by falling parts during incorrect installation or removal!

- Ensure that the product cannot roll away or fall.
- If necessary, use an appropriate mounting aid for installation or removal on a vertically suspended machine spindle.



WARNING

Serious crushing injuries caused by improper machine movement during installation or removal!

- Machine movements are only permitted in set-up mode during installation and removal.
- Never reach into a gap.
- Pay attention to the gap dimensions of moving parts.



WARNING

Serious head injuries caused by bending into the working area of the machine!

- Only ever bend into the working area of the machine if there are no cutting tools or sharp objects in it, or if these are covered.
- Never move body parts under parts in the working area of the machine with the potential to drop down.
- Depending on weight, use an appropriate mounting aid for installation or installing on a vertically suspended machine spindle.



WARNING

High level of physical strain due to the weight of the product or of its components if not transported properly!

- From a weight of 10 kg, use appropriate transport equipment, lifting gear and lifting tackle.



CAUTION

Serious cut injuries caused by sharp-edged changing parts and/or clamping elements!

- All installation / removal of changing parts and clamping elements must be performed by skilled staff from the relevant specialist field.



NOTE

Damage to materials caused by lifting gear left in the product!

- Always remove lifting gear immediately after installing the product.



NOTE [only for aluminum components]

Damage to materials can be caused by incorrect screw tightening torques on aluminum components!

- Pay attention to the reduced screw tightening torques for aluminum components [see »Screw tightening torques« chapter].

7.2 Preliminary remarks

- In accordance with their thread size and strength class, screws must be tightened crosswise to the specified tightening torque [see »Screw tightening torques« chapter]. When tightening the screws, do so evenly to prevent any distortion under load.

- To avoid precision errors, clean all screw-fitting points and mating surfaces [Notes on cleaning, see »Cleaning« chapter]. Factory wetting of flat surfaces and, where necessary of clamping elements, only serves as a corrosion inhibitor. This is not functionally related lubrication.
- Only apply lubricant to the mechanical mating surfaces. Pay attention to notes about lubricants [see »Use of lubricants« chapter].
- Avoid too much lubricant on the locating face because this can cause face run-out errors.
- Apply grease to the sealing elements [e.g. O-rings, rectangular rings] and sealing surfaces. Pay attention to notes about greases [see »Use of lubricants« chapter].
- Do not damage the functional surfaces [flat, mating, tapered and sealing surfaces].

7.3 Screw tightening torques

The tables show the specified values.

Knowledge of the applicable guidelines and design criteria is essential.



NOTE

Damage to materials caused by defective screw tightening torques!

- To secure the product to the machine, pay attention to the values specified by HAINBUCH and by the machine manufacturer for screw tightening torques. If the machine manufacturer stipulates different values, you must consult HAINBUCH.

Metric control threads

The following table contains the guide values in Nm for screw tightening torques for achieving the highest permitted preload for metric control threads.

- Total friction coefficient $\mu_{ges} = 0.12$

Thread designation	Tightening torque at screw quality [Nm]	
	10.9	12.9
M4	4	5
M5	7	9
M6	12	15
M8	25	38
M10	50	70
M12	100	130
M16	220	300
M20	400	550
M24	600	800

Table 2: Screw tightening torques, metric control threads

Aluminum components

The following table contains the reduced screw tightening torques for securing aluminum components.

Thread designation	Tightening torque [Nm]	Minimum screw depth [mm]
M6	10	12
M8	23	16
M10	46	20

Table 3: Screw tightening torques for aluminum components

7.4 Preparation of machine for installation

1. Set the machine into set-up mode.
2. Reduce the operating pressure to a minimum.
3. Remove cutting tools and/or sharp objects from the working area of the machine, or cover them.

7.5 Installation of the product

1. As described in the »Preparing the machine for installation« chapter, prepare for the following steps.

7.5.1 Compatibility check

Check the compatibility of the product and the connection point of the basic clamping device.

For this, check that the connection point and the product share the same adaptation geometry. Also check if the actuating element / coupling element is suitable.

7.5.2 Preparation of the product

The product is supplied in assembled condition.

No preparatory steps are needed to install the product.

7.5.3 Installation of the product on the clamping device

1. Move the clamping device into release position.



INFORMATION

Installation / removal of the product is described in the operating instructions for the clamping device.



In addition to these operating instructions, also read and follow the operating instructions for the relevant clamping device.

2. Install the product.

8 Commissioning

For commissioning purposes, set the operating pressure to the permitted, established machining value.

The machine tool must not start up until full operating pressure has built up.

8.1 Commissioning safety



DANGER

Serious injuries caused by workpieces being ejected centrifugally or dropping out if clamping force is insufficient!

- Workpiece blanks must not be outside the clamping width diameter.
- Prior to commissioning, set the actuation force to the permitted, established machining value.
- Check the clamping force at regular intervals and correct if necessary.



WARNING

Serious injuries can be caused if the machine tool starts up accidentally!

- Prior to commissioning, close all safety doors or hoods on the machine tool.



WARNING

Serious injuries caused by tools and items of test equipment being ejected centrifugally!

- Prior to commissioning, ensure that all tools and items of test equipment are removed from the working area of the machine.



NOTE

Serious damage to materials / the product caused by workpieces being ejected centrifugally or dropping out if clamping force is insufficient!

- Workpiece blanks must not be outside the clamping width diameter.
- Prior to commissioning, set the actuation force to the permitted, established machining value.
- Check the clamping force at regular intervals and correct if necessary.



NOTE

Damage to components caused by cooling lubricants with sufficient levels of corrosion inhibitor!

- The components made of steel materials must be protected before the usual oxidation process.
- Only ever use cooling lubricants with sufficient levels of corrosion inhibitor.



NOTE

Damage to materials caused by contaminated / unprocessed cooling lubricants!

- For the product to function properly, in particular for internal flushing with cooling lubricants and/or when using tools with internal flushing, ensure that the cooling lubricant is cleaned / processed, and that it contains no particles measuring >100 microns [filtered with a mesh width of 100 microns].



NOTE

Damage to seals caused by using the wrong coolant lubricants!

- To clean the product, never use a cooling lubricant that attacks and damages the sealing elements installed. Those installed sealing elements can be made of NBR, Viton and PUR materials.
- Never use cooling lubricants that contain ester or a polar solvent.

8.2 Tests



NOTE

Serious damage to, or destruction of, the machine tool and the workpiece caused by damaged, incomplete or incorrectly installed products!

- Only install undamaged and complete products properly.
- If in doubt, contact the manufacturer.

Assure the following points before every installation and/or before every time the products are put into service:

- The products used are undamaged.
- All fixing screws are present on the products, and are tightened to the correct tightening torque.
- None of the edges and races are chipped or show any signs of wear.

- The speed set on the machine tool must not exceed the maximum speed of the product. Always take the lowest value of all maximum speeds for combined products indicated.
- Do not exceed the maximum technical data indicated on the product.
- All installation tools are removed from the machining area.
- Clamping device and workpiece are compatible.

8.3 Procedure after a collision

In the event of a collision, the product and its components must be checked for cracks and damage before being used again.

9 Removal

If a break in production occurs that lasts for more than three days, the product must be removed and stored safely in accordance with the manufacturer's stipulations [see »Transport, packaging, storage« chapter].

9.1 Safe removal



WARNING

Serious injuries caused by unskilled staff during installation / removal!

- Installation and removal must be performed by skilled staff from the relevant specialist field.



WARNING

Serious injuries can be caused if the machine tool starts up accidentally!

- Set the machine tool into set-up mode.
- Remove all tools, auxiliary equipment and items of test equipment immediately from the working area of the machine.
- Remove all lifting gear from the product and from the working area of the machine.



WARNING

Serious injuries caused by the escape of media under high pressure!

- Shut down media delivery during installation and removal.
- Relieve any pressure trapped in the system.
- Shut down the system.



WARNING

Serious crushing injuries and breakages caused by falling parts during incorrect installation or removal!

- Ensure that the product cannot roll away or fall.
- If necessary, use an appropriate mounting aid for installation or removal on a vertically suspended machine spindle.



WARNING

Serious crushing injuries caused by improper machine movement during installation or removal!

- Machine movements are only permitted in set-up mode during installation and removal.
- Never reach into a gap.
- Pay attention to the gap dimensions of moving parts.



WARNING

Serious head injuries caused by bending into the working area of the machine!

- Only ever bend into the working area of the machine if there are no cutting tools or sharp objects in it, or if these are covered.
- Never move body parts under parts in the working area of the machine with the potential to drop down.
- Depending on weight, use an appropriate mounting aid for installation or installing on a vertically suspended machine spindle.



WARNING

High level of physical strain due to the weight of the product or of its components if not transported properly!

- From a weight of 10 kg, use appropriate transport equipment, lifting gear and lifting tackle.



CAUTION

Serious cut injuries caused by sharp-edged changing parts and/or clamping elements!

- All installation / removal of changing parts and clamping elements must be performed by skilled staff from the relevant specialist field.



INFORMATION

If necessary, use any forcing / extraction threads in the components of the product, changing parts or clamping elements.

9.2 Preparing the machine for removal

1. Set the machine into set-up mode.
2. Reduce the operating pressure to a minimum.
3. Remove cutting tools and/or sharp objects from the working area of the machine, or cover them.
4. Remove operating and auxiliary materials as well as remaining processing materials and dispose of them in an environmentally responsible manner.

9.3 Removal of the product

1. As described in the »Preparing the machine for removal« chapter, prepare for the following steps.

9.3.1 Removal of the product from the clamping device

1. Move the clamping device into release position.



INFORMATION

Installation / removal of the product is described in the operating instructions for the clamping device.



In addition to these operating instructions, also read and follow the operating instructions for the relevant clamping device.

2. Remove the product.

9.4 Removal of the product

It may be necessary to dismantle the product for cleaning, setting of spring force or for replacement of the springs.

Depending on the version of the product, they can be removed as follows.



INFORMATION

The next section only deals with the disassembly of components under spring load. It may prove necessary before disassembly to remove other components that are not under spring load.

1. As described in the »Preparing the machine for removal« chapter, prepare for the following steps.
2. Move the clamping device into release position.
3. Remove the product from the clamping device [see »Removal of product« chapter].

9.4.1 Disassembly of the cover variant / axially screwed centrally

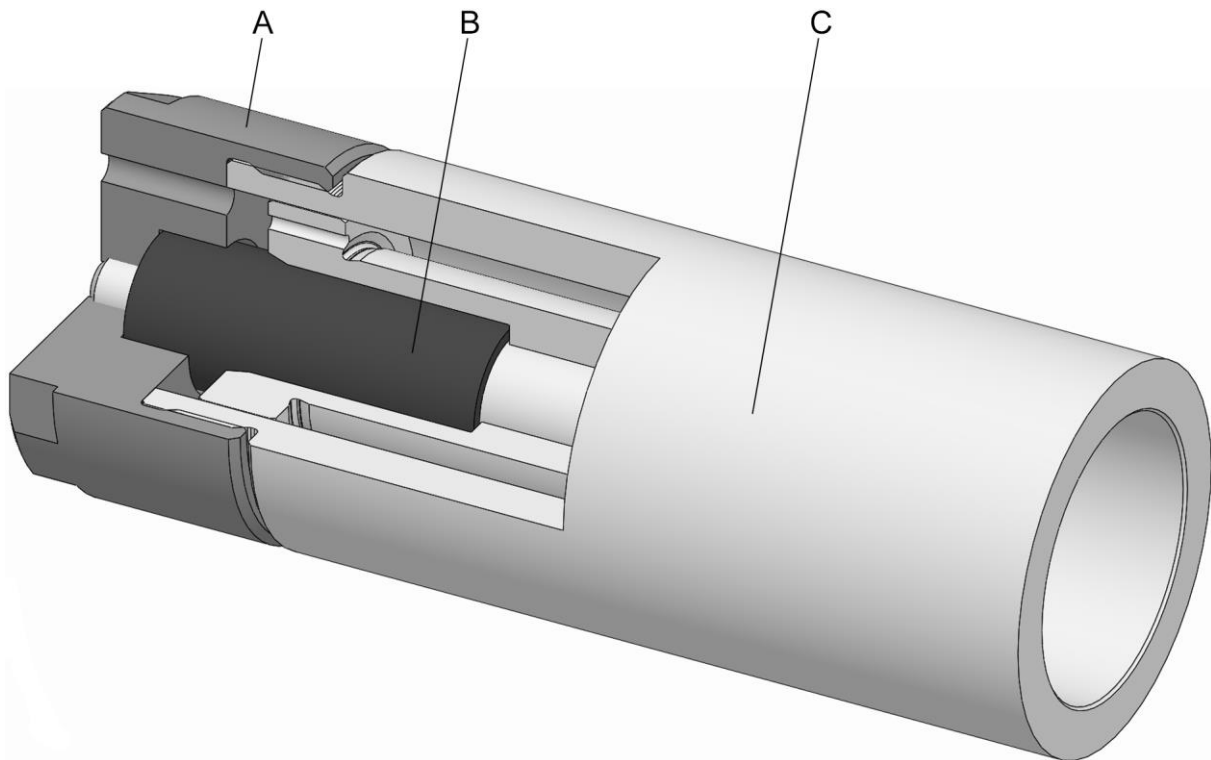

- A Cover
- B Spring
- C Changing part

1. Carefully unfasten and remove the cover / screw from the changing part. This reduces spring force completely, or to a low level of force.
2. Clean the components of the changing part.
3. Adjust spring force if necessary and / or replace the springs if required.
4. Screw the cover onto the changing part and tighten to the specified tightening torque [see nomenclature].



INFORMATION

If necessary, the cover / screw is secured with medium-strength screw adhesive.

Before reinstallation, clean and degrease the cover / screw.

The screw / cover needs to be secured again using a standard, medium-strength screw adhesive and tightened to the specified tightening torque [see nomenclature or the »Screw tightening torques« chapter].

9.4.2 Disassembly of the variant x-times with axial screw connection

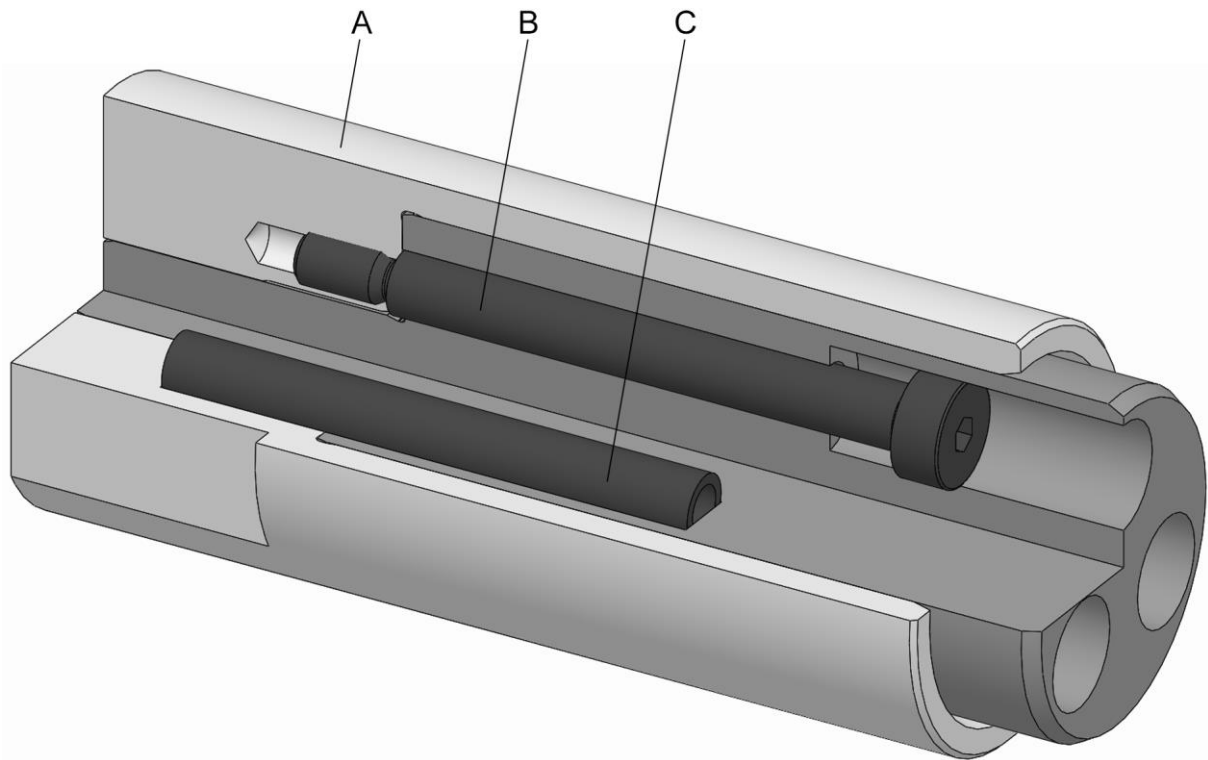

- A Changing part
- B Screws
- C Springs

1. Unfasten the screws carefully, uniformly, alternately and crosswise to reduce clamping action to a minimum.
2. Remove the screws.
3. Clean the components of the changing part.
4. Adjust spring force if necessary and / or replace the springs if required.
5. Screw in the screws uniformly, alternately and crosswise, and tighten to the specified tightening torque [see »Screw tightening torques« chapter].

9.4.3 Disassembly of the radially screwed variant

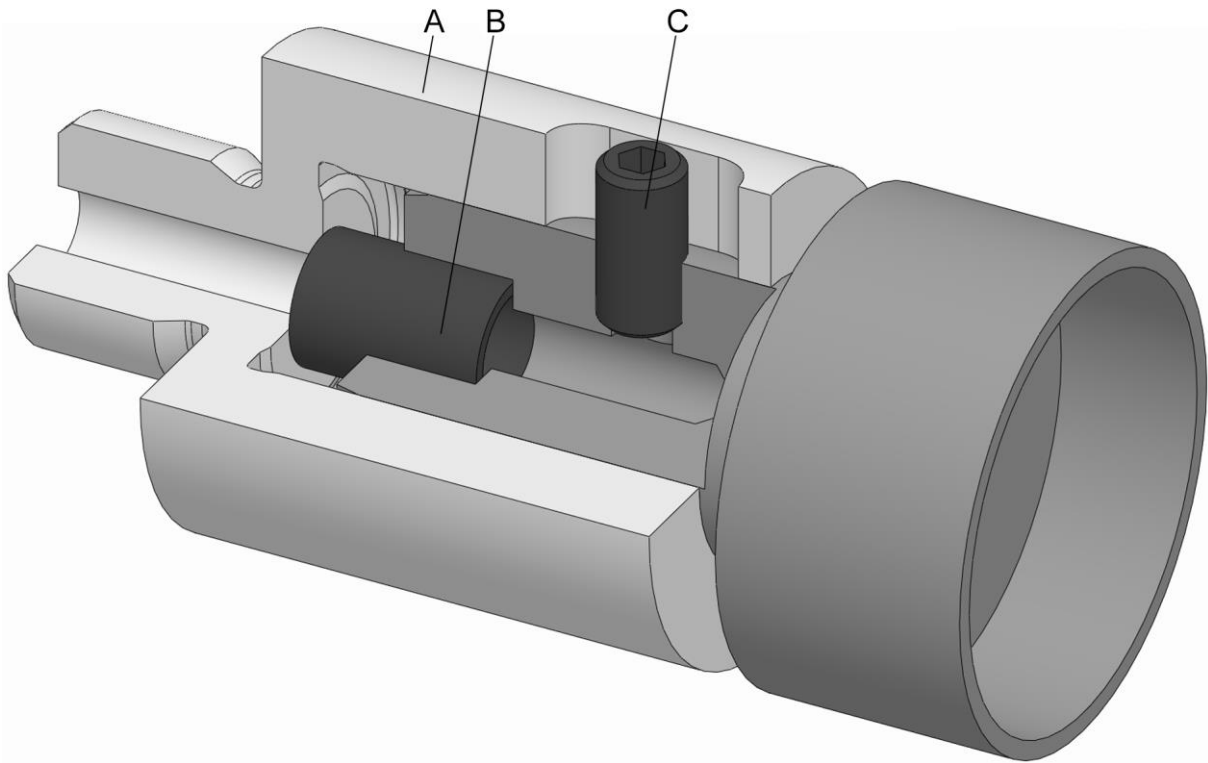

- A Changing part
- B Spring
- C Screw / threaded dowel



WARNING

Serious injuries from unintended projectile components caused by release of stored energy!

- Particular caution is required.

1. Relieve tension on the screw / the threaded dowel by pressing the components under spring load together and keeping them held down.
2. Unfasten and remove the screw / the threaded dowel.
3. Carefully relieve the spring force by releasing tension on the components under spring load.
4. Clean the components of the changing part.
5. Adjust spring force if necessary and / or replace the springs if required.
6. Relieve spring tension by pressing the relevant components together and keeping them held down.
7. Screw in the screw / threaded dowel into the changing part and tighten it to the specified tightening torque [see »Screw tightening torques« chapter].
8. Release tension of the components under spring force.

9.4.4 Removal of the axial retaining ring variant

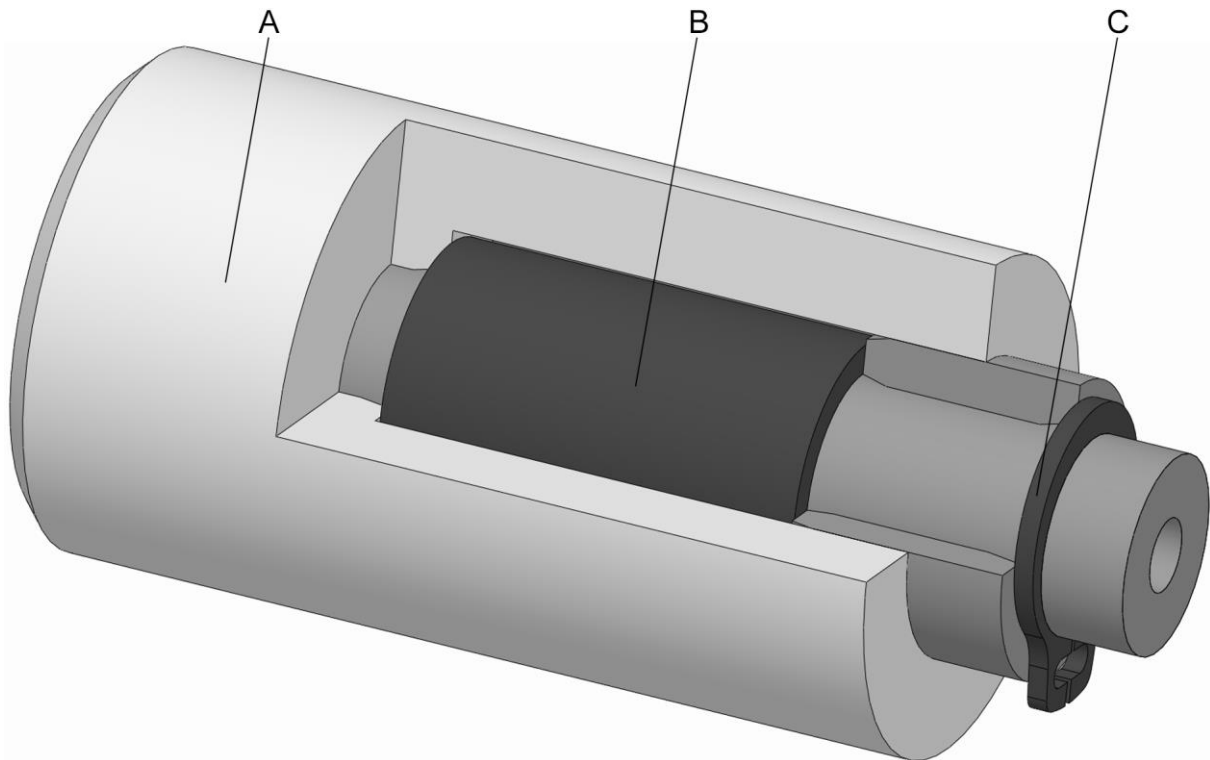

- A Changing part
- B Spring
- C Retaining ring

1. Relieve tension on the retaining ring by pressing the components under spring load together and keeping them held down.
2. Remove the retaining ring.
3. Carefully relieve the spring force by releasing tension on the components under spring load.
4. Clean the components of the changing part.
5. Adjust spring force if necessary and / or replace the springs if required.
6. Relieve spring tension by pressing the relevant components together and keeping them held down.
7. Install the retaining ring in the changing part.
8. Release tension of the components under spring force.

10 Maintenance

10.1 Maintenance safety



WARNING

Serious injuries caused by parts being ejected centrifugally after a loss of clamping power!

- Maintain the maintenance and cleaning intervals of the product at all times.



CAUTION

Health risks caused by incorrect handling of cleaning agents!

- Pay attention to hazard specifications and the safety data sheet of the manufacturer.

10.2 Maintenance schedule

The following sections describe the maintenance work needed to ensure optimum and fault-free operation.

If increased levels of wear are detected during regular checks, shorten the maintenance intervals to reflect the actual rate at which signs of wear appear.

Contact the manufacturer for questions relating to maintenance work and maintenance intervals [see »Contact« chapter].

Interval	Maintenance work
daily	Visual inspection of wear locations, nicks and cracks [see »Visual inspection« chapter]
	Complete cleaning if heavily soiled [see »Cleaning« chapter]
six-monthly or after 3000 operating hours*	Completely clean the product [see »Cleaning« chapter]
with storage	See »Storage« chapter

* depending upon which stipulation is achieved first

Table 4: Maintenance table

10.3 Cleaning



WARNING

Eye injuries and cuts caused by failure to wear protective clothing during cleaning operation!

- Never use compressed air to clean the product.
- Also wear the following items of personal protective equipment, in addition to the basic equipment:



NOTE

Damage to seals caused by the wrong solvent!

- To clean the product, never use a solvent that attacks and damages the sealing elements installed. Those installed sealing elements can be made of NBR, Viton and PUR materials.
- To clean the product, never use a solvent that contains ester, nor a polar solvent.



NOTE

Damage to materials caused by incorrect installation of sealing elements!

- Replace missing or damaged sealing elements.
- Ensure that the sealing elements do not fall out or get damaged during installation / removal, and apply a thin coat of grease if necessary.

Cleanliness of the relevant limit stop and guide diameter are essential for achieving axial and face run-out tolerances.

1. Dismantle the changing part from the clamping device [see operating instructions for the clamping device].



WARNING

Serious injuries caused by an absence of clamping force resulting from incorrect reassembly!

- Pay attention to the sequence and arrangement of the springs.

2. Dismantle the product. Pay attention to the following during disassembly:
 - To dismantle the product, see the »Disassembly of product« chapter.

- Unfasten the screws uniformly, alternately and crosswise.
- 3. Clean all oil and grease residues off all components with an ester-free, non-polar, soft, lint-free cloth and check for visible signs of damage.
- 4. Assemble the product. Pay attention to the following during assembly:
 - Replace worn or damaged fixing screws.
 - Tighten all fixing screws to the specified tightening torque [see nomenclature and/or »Screw tightening torques« chapter]. When tightening the screws, do so evenly to prevent any distortion under load.
 - Only apply lubricant to the mechanical mating surfaces. Pay attention to notes about lubricants [see »Use of lubricants« chapter].
 - Avoid too much lubricant on the locating face because this can cause face run-out errors.
 - Apply grease to the sealing elements [e.g. O-rings, rectangular rings] and sealing surfaces. Pay attention to notes about greases [see »Use of lubricants« chapter].
 - Reinstall the springs in the same sequence and arrangement.

10.4 Visual inspection

Perform a daily visual inspection of the product to identify any damage to the product at an early stage.

Check the product for cracks and damage.

A check is also required to ensure that all fixing screws are tightened down.

If damage is detected, the relevant components must be exchanged immediately for genuine spare parts from the manufacturer.

Complete cleaning of the product is required if heavily soiled [see »Cleaning« chapter].

10.5 Use of lubricants

To achieve ultimate performance from the products, use the specified lubricants.

Only use grease that complies with the fundamental requirements governing adhesion, pressure resistance and solubility in coolants. Furthermore, there must be no particles of dirt in the grease because these cause an operational malfunction if they come between two interference fit surfaces. For this, the following lubricants are recommended:

GP 355 universal grease

[see the HAINBUCH product catalogue]

Alternatively:

Lubricants	Manufacturer	Product designation
Grease	MicroGleit	GP 355
	Klüber	QNB 50
	Zeller & Gmelin	DIVINOL SD24440
	Bremer & Leguill	RIVOLTA W.A.P.

Table 5: Selection of lubricants



NOTE

Malfunction of the product due to a combination of different greases!

- Never mix different greases with one another.
- Clean the product completely before using a different grease.

11 Disposal

If no agreement exists for return or disposal, send dismantled components off for recycling.



NOTE

Substantial damage to the environment can result from incorrect disposal of environmentally hazardous substances!

- Lubricants, auxiliary materials and operating fluids are governed by legislation for the processing of special-category waste: All disposal to be performed by authorized waste disposal specialists.

Catch exchanged oils and greases in suitable containers and dispose of them in accordance with applicable local provisions.

The local municipal authority or specialist waste disposal companies can provide information about environmentally compliant disposal.

12 Faults

The following chapter describes possible causes for faults, and the work involved in remedial action.

If multiple faults occur, shorten the maintenance intervals in accordance with actual load levels.

Contact the manufacturer if faults occur that cannot be remedied by following these instructions [see »Contacts« chapter].

12.1 Procedure with faults

This applies in all cases:

1. With faults that constitute an immediate danger to people or capital equipment, press the Emergency Stop button on the machine tool immediately.
2. Establish the cause of the fault.
3. If troubleshooting requires work to be conducted in the danger area, switch the machine tool into set-up mode.
4. Notify the person on location of the fault immediately.
5. Depending on the type of fault, get it remedied by authorized and appropriately skilled specialists.



INFORMATION

The troubleshooting table in the following section provides information about who is authorized to remedy a given fault.

6. In the event of a fault not caused by the product, the fault may be caused by something close to the machine tool. For this, refer to the operating instructions of the machine tool.

12.2 Fault table

Fault	Possible cause	Remedial action	Remedied by
	Compression springs are fatigued	Replace the compression springs	Skilled specialist
Spring release stroke is too short	Product is jamming due to dirt	Clean / rinse the product	Skilled specialist
		Disassembly and cleaning	Skilled specialist
Spring loading action is too weak	Product is jamming due to dirt	Clean / rinse the product	Skilled specialist
		Disassembly and cleaning	Skilled specialist
Spring force is too weak	Compression springs are fatigued	Replace the compression springs	Skilled specialist

Table 6: Fault table

12.3 Commissioning after a fault has been remedied

After the fault has been remedied, perform the following steps to recommission it:

1. Reset the emergency stop equipment.
2. Acknowledge the fault on the control unit of the machine tool.
3. Ensure that no-one is in the danger area.
4. Start the machine tool.

13 Annex

13.1 Contact

The following hotlines are available to you for orders, schedule tracking and emergencies.

Order hotline

Ordered quickly, supplied swiftly. Just phone:

+49 7144. 907-333

Tracking hotline

Current status of your order? Just call:

+49 7144. 907-222

24 hour emergency phone line

Has a system crash occurred, or some other technical emergency?

Our experts are there for you around the clock:

+49 7144. 907-444

For advice or help, you can contact the sales partners and service staff listed in www.hainbuch.com.

13.2 Manufacturer certification

Manufacturer certification is supplied with the product and with this manual.

Index directory

A		Pneumatics specialist 11
Accessories, needed		Skilled specialist..... 11
Clamping devices 22		Trainees 11
B		Protective equipment
Brief description 22		Hair net 14
C		Hard hat 15
Cleaning..... 44		Protective gloves..... 14
Copyright 8		Protective goggles 14
D		Safety footwear 14
Definition of terms 7		Workplace clothing..... 14
E		Preservation 27
Environmental protection 19		R
F		Removal
Fault table 49		Preparation of the machine 38
Faults 48		Product..... 38
H		S
Hazards 15		Safety
I		Commissioning 33
Installation		General 10
Preparation of machine..... 32		Maintenance 43
Preparation of the product 32		Removal..... 36
Product 32		Transport, packaging, storage 24
Installation safety 28		Scope of delivery..... 8
Intended use 12		Screw tightening torques
K		Aluminum components..... 32
Key to symbols..... 6		Metric control threads 31
L		Spare parts..... 9
Layout 22		Speed..... 20
Liability 8		Storage..... 27
Lubricants 19, 46		Symbols on the packaging 25
M		T
Maintenance schedule 43		Technical data 20
Misuse 13		Tests 34
O		Transport inspection..... 25
Operating conditions 20		Transportation, internal 26
P		Type designation 21
Packaging 26		U
Performance values 20		Unpacking 26
Personnel requirements 10		W
Electricians 11		Warranty..... 9
Hydraulics specialist 11		



HAINBUCH GMBH · SPANNENDE TECHNIK

Postfach 1262 · 71667 Marbach / Erdmannhäuser Strasse 57 · 71672 Marbach · Germany

Tel. +49 7144.907-0 · Fax +49 7144.18826 · verkauf@hainbuch.de · www.hainbuch.com

24 hour emergency phone line + 49 7144.907-444

02.2020 - 065.11/0080 EN - Technical modifications reserved