

Operating instructions

[incl. installation manual]

MAXXOS T211

EN

Translation of the original operating instructions

Contents

1	General.....	7
1.1	Information about this manual.....	7
1.2	Key to symbols.....	7
1.3	Definition of terms	8
1.3.1	Release setting.....	8
1.3.2	Complete clamping reserve	8
1.4	Limitation of liability	9
1.5	Copyright.....	9
1.6	Scope of delivery	9
1.7	Spare parts and accessories.....	10
1.8	Warranty terms	10
2	Safety	11
2.1	Responsibility of the operator.....	11
2.2	Personnel requirements	12
2.3	Intended use	13
2.4	Personal protective equipment.....	15
2.5	Particular hazards	16
2.6	Other safety instructions	18
2.7	Screws	20
2.8	Functionality.....	20
2.9	Environmental protection	21
3	Technical data	22
3.1	General information.....	22
3.2	Performance values	23
3.3	Balancing quality	23
3.4	Speed.....	24
3.5	Operating conditions	24
3.6	Type designation.....	24
4	Layout and function	25
4.1	Overview and brief description	25
4.2	Accessories required.....	26
4.2.1	Spindle flange.....	26
4.2.2	Drawtube adapter	26
4.2.3	Segmented clamping bushing	26
4.2.4	Workpiece end-stop.....	26
4.3	Optional accessories.....	26
4.3.1	Adapter for checking the air system	26
4.3.2	hs dock actuating unit.....	26
4.3.3	Rotating ms dock actuating unit.....	27
4.3.4	ms dock stationary actuating unit	27
5	Use and limits of use	28

5.1	Use.....	28
5.2	Limits of use.....	28
5.2.1	Nomenclature	28
5.2.2	First limit [workpiece length]	28
5.2.3	Second limit [workpiece mass]	29
5.2.4	Third limit [clamping length]	29
5.2.5	Fourth limit [forces]	30
6	Transport, packaging, storage.....	31
6.1	Safety, transport, packaging, storage	31
6.2	Symbols on the packaging	32
6.3	Transport inspection.....	32
6.4	Unpacking and internal transportation.....	33
6.5	Packaging	33
6.6	Storage	34
6.7	Preservation.....	34
6.8	Return to storage	34
7	Installation	35
7.1	Installation safety	35
7.2	Preliminary remarks	37
7.3	Screw tightening torques.....	37
7.4	Preparation of the machine for installation	39
7.5	Installation of the product	39
7.5.1	Compatibility check.....	39
7.5.2	Preparation of the product	40
7.5.3	Installation of the product on an actuating unit	43
7.5.4	Installation of the drawtube adapter.....	44
7.5.5	Installation of a spindle flange that cannot be aligned	44
7.5.6	Installation of a spindle flange that can be aligned	46
7.5.7	Installation of the functional unit of an alignable clamping device	48
7.5.8	Installation of the functional unit of a non-alignable clamping device	51
7.6	Installation of the clamping element.....	55
7.7	Installation of the changing parts	57
7.7.1	Installation of the variant x-times with axial screw connection.....	58
7.7.2	Installation of the variant x-times with bayonet axial screw connection	59
7.8	Aligning the clamping device with the test specimen	60
8	Commissioning.....	61
8.1	Commissioning safety	61
8.2	Checking the total stroke.....	63
8.3	Tests	63
8.4	Workpiece	64
8.5	Procedure after a collision.....	65

9	Activities after end of production	66
10	Removal	67
	10.1 Safe removal	67
	10.2 Preparing the machine for removal	69
	10.3 Removal of the changing parts	69
	10.3.1 Removal of the variant x-times with axial screw connection	70
	10.3.2 Removal of the variant x-times with axial screw connection bayonet.....	71
	10.4 Removal of the clamping element.....	72
	10.5 Removal of the product.....	75
	10.5.1 Removal of the product from an actuating unit	75
	10.5.2 Removal of the functional unit	76
	10.5.3 Removal of the spindle flange	78
	10.5.4 Removal of the drawtube adapter.....	79
11	Maintenance.....	80
	11.1 Maintenance safety	80
	11.2 Maintenance schedule	81
	11.3 Cleaning.....	82
	11.4 Visual inspection	84
	11.5 Lubricating the product.....	85
	11.6 Use of lubricants	86
12	Disposal.....	87
13	Faults.....	88
	13.1 Procedure with faults.....	88
	13.2 Fault table	89
	13.3 Commissioning after a fault has been remedied	90
14	Annex	91
	14.1 Contact.....	91
	14.2 Manufacturer certification.....	91

Directory of tables

Table 1:	Technical data	22
Table 2:	Operating conditions	24
Table 3:	Nomenclature application limits.....	28
Table 4:	Maximum workpiece mass	29
Table 5:	Screw tightening torques, metric control threads.....	38
Table 6:	Screw tightening torques for aluminum components.....	38
Table 7:	Maintenance table	81
Table 8:	Selection of lubricants	86
Table 9:	Fault table.....	90

1 General

1.1 Information about this manual

This manual enables you to work safely and efficiently with the product.

This manual is part of the product and must be kept in a location directly beside the product that is accessible to the personnel at all times. The personnel must have read this manual carefully and understood its contents before starting any work. The basic requirement for safe work is compliance with all stipulated safety notices and work-related instructions in this manual.

If the product is passed onto a third party, this manual must accompany it.

Illustrations in this manual are there to facilitate a basic understanding, and may differ from the actual design configuration of the product.



WARNING

Serious injuries caused by individual products or by inappropriate combinations of them!

- Read and pay attention to all operating instructions for individual products and combinations of them.

1.2 Key to symbols

Safety instructions in this manual are designated by symbols. The safety notices are invoked by signal words that express the level of hazard involved.

Always comply with safety notices and exercise caution to avoid accidents, injury to people and damage to materials.

Safety notices



DANGER

... indicates an immediate and hazardous situation that can lead to death or serious injury if not avoided.



WARNING

... indicates a potentially hazardous situation that can lead to death or serious injury if not avoided.



CAUTION

... indicates a potentially hazardous situation that can lead to moderate or slight injuries if not avoided.



NOTE

... indicates a potentially hazardous situation that can lead to damage to materials if not avoided.

Tips and recommendations



INFORMATION

... highlights useful tips and recommendations as well as information for efficient and problem-free operation.



... refers to other documents relating to personal and general safety.

Warning symbols may appear on the product or its components.

Always pay attention to warning symbols, and exercise caution to avoid accidents, injury to people and damage to materials.



... warns of stored energy [for example involving springs].



... warns of hand injuries.



... draws attention to the fact that the operating instructions of the product must be read.

1.3 Definition of terms

1.3.1 Release setting

Release setting means that the clamping device is released. If the clamping device is released, this also releases the workpiece.

1.3.2 Complete clamping reserve

Complete clamping reserve means that the clamping device is clamped without a workpiece. The complete stroke has been used up, which means that the clamping device is therefore at the limit position for clamping reserve.

1.4 Limitation of liability

All details and notices in this manual were compiled with due reference to applicable standards and specifications, state-of-the-art technology and our many years of expertise and experience.

The manufacturer accepts no liability for damage arising from any of the following:

- Non-compliance with this manual
- Unintended use
- Use of untrained personnel
- Autonomous conversion work
- Technical modifications
- Use of non-approved spare parts
- Use of non-approved accessories
- Installation and use of clamping elements not made by the manufacturer

Subject to any commitments agreed to in the supplier contract, the General Terms & Conditions of Business and the delivery terms of the manufacturer and all legislative stipulations valid at the time of conclusion of this contract.

1.5 Copyright

This manual is protected by copyright, and are only intended for internal use.

The dissemination of this manual to third parties, reproductions in any shape or form - even in part - as well as commercial use and/or communication of their contents are prohibited for anything other than internal use, except with the written consent of the manufacturer.

Infringements oblige the offending party to pay compensation. Without restriction on further claims.

1.6 Scope of delivery

The scope of delivery of this product includes:

- MAXXOS T211
- The operating instructions

Additionally needed and included as optional items in the scope of delivery:

- Spindle flange
- Drawtube adapter
- Segmented clamping bushing
- Workpiece end-stop

1.7 Spare parts and accessories



WARNING

Serious injuries can be caused by incorrect or defective spare parts!

- Always use genuine spare parts made by the original manufacturer.



WARNING

Serious injuries can be caused by incorrect or defective clamping elements!

- Always use genuine clamping elements made by the original manufacturer.



NOTE

Damage, malfunctions or total failure of the product or the machine tool caused by an incorrect or defective spare parts!

- Always use genuine spare parts made by the original manufacturer.



NOTE

Damage, malfunctions or total failure of the product or the machine tool caused by an incorrect or defective clamping elements!

- Always use genuine clamping elements made by the original manufacturer.

Spare parts and accessories can be sourced from contract dealers or directly from the manufacturer [see »Contact« chapter].

Without exception, wearing parts and components in contact with the workpiece are not covered by warranty.

1.8 Warranty terms

The warranty terms are included in the manufacturer's General Terms & Conditions of Business.

2 Safety

This section provides an overview of all the important safety aspects for optimum protection of personnel, and for safe and problem-free operation.

2.1 Responsibility of the operator

The product is used in the industrial sector. The operator of the product is therefore governed by the provisions of Health & Safety at Work legislation.

As well as the safety notices in this manual, the area of use of the product must also comply with locally applicable safety, accident prevention and environmental protection specifications as well as those in the manual for the machine tool.

No modifications must be made to the product. The operator is wholly and solely responsible for any resultant personal injury and/or damage to materials.

Excepted from this are changing parts that HAINBUCH approved explicitly for autonomous machining, but specified limits must never be exceeded.



DANGER

Serious injuries caused by parts being ejected centrifugally due to a drop in actuating force / supply pressure!

- On the machine, ensure that the actuating force / the supply pressure do not drop while the product is in use.
- If no precautions have been taken on the machine to maintain the actuating force / the supply pressure, it is prohibited to use this product on the machine.
- Pay attention to the operating instructions for the machine tool.

In particular, note that end-stop requests by the machine tool must be set on the product involved.



DANGER

Serious injuries caused by parts being ejected centrifugally after defective setting of the machine!

- Set up the end-stop requests by the machine tool on the product involved.
- On a regular basis, check the end-stop requests of the machine tool [see »Maintenance schedule« chapter].
- If the limit stops are not reached, the product must not be used any more.

2.2 Personnel requirements



WARNING

Serious injuries caused by incorrect handling of the product by insufficiently skilled or trained personnel!

- All activities must be performed by skilled staff from the relevant specialist field.



WARNING

Serious injuries caused by unauthorized presence of unauthorized personnel in the working area!

- Keep unauthorized people away from the working area.
- If in doubt, speak to people and direct them to leave the working area.
- Interrupt work until unauthorized people have left the working area.



NOTE

Serious damage to materials caused by incorrect handling of the product by insufficiently skilled or trained personnel!

- All activities must be performed by skilled staff from the relevant specialist field.

This manual name the following skills sets required for various different areas of activity:

Skilled specialist

Skilled specialists, due to their professional training, knowledge and experience and awareness of applicable provisions, are capable of carrying out the work entrusted to them and independently to identify and avoid potential hazards.

Hydraulics specialist

Hydraulics specialists are trained in the specific task profile for which they are employed, and are familiar with the relevant standards and legislative provisions.

Due to their vocational training and experience, hydraulics specialists can work on hydraulic systems and can independently identify and avoid potential hazards.

Pneumatics specialist

Pneumatics specialists are trained in the specific task profile for which they are employed, and are familiar with the relevant standards and legislative provisions.

Due to their vocational training and experience, pneumatics specialists can work on pneumatic systems and can independently identify and avoid potential hazards.

Electricians

Electricians are trained in the specific task profile for which they are employed, and are familiar with the relevant standards and legislative provisions.

Due to their vocational training and experience, electricians can work on electrical systems and can independently identify and avoid potential hazards.

Trainees

Trainees can only work on the machine under the supervision and direction of staff skilled in the relevant specialist field.

The only people admitted as personnel are those who can reasonably be expected to carry out their work to a reliable standard. People whose response capabilities are impaired, for example by drugs, alcohol or medication, are prohibited. For the selection of personnel, pay attention to the stipulations applicable at the place of work governing age and specific vocational requirements.

2.3 Intended use

The product is only intended for installation in a CE-compliant machine tool with a separating set of guards.

The product is only intended for the type of use described in this manual [see »Use« chapter]. Furthermore, an extended form of use can be agreed contractually between manufacturer and operator.

Only skilled staff from the appropriate specialist fields may install, operate, maintain and clean the product [see »Personnel requirements« chapter].

Never exceed the technical values stipulated for the product [see »General information« and »Operating conditions« chapters].

Furthermore, never exceed the limits for use of the product [see »Limits of use« chapter].

Maintain the product at regular intervals [see »Maintenance schedule« chapter].

When used for its intended purpose, the operational safety of the product is assured, subject to compliance with relevant safety stipulations, to the full extent foreseeable.

Intended use also includes compliance with all stipulations in this manual.

Any form of use beyond the scope of intended use, or other forms of use of the product, is considered as misuse, and can lead to dangerous situations.



DANGER

Serious injuries caused by misuse of the product!

- Only in a CE-compliant machine tool with a separating set of guards.
- Only use for the type of use indicated [see »Use« chapter].
- Only skilled staff from the appropriate specialist fields may use the product [see »Personnel requirements« chapter].
- Never exceed the technical data indicated on the product [see »General information« and »Operating conditions« chapters].
- Never exceed the limits for use of the product [see »Limits of use« chapter].
- Maintain the product at regular intervals [see »Maintenance schedule« chapter].
- Only use with approved attachments and/or clamping elements.



DANGER

Serious injuries caused by parts being ejected centrifugally during commissioning without a workpiece!

- Never rotate the product without a workpiece installed.
- For commissioning, clamp an appropriate workpiece at every available clamping point.



NOTE

Damage to materials caused by incorrect use of the product!

- Only in a CE-compliant machine tool with a separating set of guards.
- Only use for the type of use indicated [see »Use« chapter].
- Only skilled staff from the appropriate specialist fields may use the product [see »Personnel requirements« chapter].
- Never exceed the technical data indicated on the product [see »General information« and »Operating conditions« chapters].
- Never exceed the limits for use of the product [see »Limits of use« chapter].
- Maintain the product at regular intervals [see »Maintenance schedule« chapter].
- Only use with approved attachments and/or clamping elements.

Claims of all kinds will be rejected that are due to unintended use.

Here are some examples of unintended use of the product

- If workpieces are not clamped properly.
- If people fail to observe the safety stipulations when working on the product, and failing to use additional protective equipment, for example to machine clamped workpieces.
- If the product is used on machines, workpieces and/or changing parts for which it is not intended.

2.4 Personal protective equipment

During work, it is essential to wear personal protective equipment to minimize the health hazards.

Always wear the required personal protective equipment when working on any given job.

Always pay attention to any notices about personal protective equipment displayed in the working area.

Always wear



Workplace clothing

Workplace clothing should be close-fitting, with low tear-resistance, narrow cuffs and no protruding parts. It serves primarily to protect the wearer from coming into contact with moving machine parts. Do not wear rings, chains or other jewelry.



Safety footwear

To protect the wearer from any heavy items that may fall, and from losing their footing on slippery ground.



Protective goggles

To protect the eyes from projectile parts and liquid splashes.



Hair net

To protect long hair from getting snagged in rotating parts on the machine tool.

Additional personal protective equipment

When carrying out certain work, additional personal protective equipment is required. Separate reference is made to this in the individual chapters of this manual. The following section explains these additional items of personal protective equipment:



Protective gloves

To protect the hands from friction, chafing, stabbing or deeper injuries and from contact with hot surfaces.



Hard hat

To protect against falling and projectile parts and materials.

2.5 Particular hazards

The following section names residual risks resulting from the installation of the product in a machine tool. In all cases, the residual risks detected during a risk assessment of the machine tool need to be named by the operator.

Pay attention to the safety instructions named here, as well as the warning notices in other chapters of these operating instructions to reduce the risk of health hazards and to prevent dangerous situations.

Moving parts



WARNING

Serious injuries caused by touching rotating and/or moving parts!

- Do not open guards while the system is operating.
- During operation, do not reach for rotating and/or moving parts.
- Pay attention to the gap dimensions of moving parts.
- Before opening the guards, ensure that none of the parts are moving any more.

Stroke



WARNING

Serious crushing injuries caused by the stroke of the product!

- Never reach into an area where moving parts are operating.
- Prevent accidental initiation of the clamping process [for example due to an installation error with the power supply or a programming error].

Insufficient workpiece clamping



DANGER

Serious injuries caused by parts being ejected centrifugally if level of workpiece clamping is insufficient!

- Workpiece blanks must not be outside the clamping width diameter.
- Clamping of the workpiece must not be outside the defined limits [see »Limits of use« chapter].
- Do not exceed the maximum performance values [see »General information« chapter].

Insufficient workpiece clamping



WARNING

Serious injuries caused by breakage of individual components of the product when actuating force is too high!

- Check actuating force on a regular basis and adjust if necessary.

Sharp-edged parts



WARNING

Serious cut injuries caused by sharp-edged parts and burrs!

- All installation of individual parts must be performed by skilled staff from the relevant specialist field.
- Also wear the following items of personal protective equipment, in addition to the basic equipment:



2.6 Other safety instructions



DANGER

Serious injuries caused by workpieces being ejected centrifugally when clamping unit is released while still rotating!

- Never release the clamping of the workpiece while it is still rotating.



DANGER

Serious injuries caused by projectile workpieces!

- To assist clamping of the workpiece with long clamping devices, always use a tailstock / back rest or a brace.



WARNING

Serious head injuries caused by bending into the working area of the machine!

- Only ever bend into the working area of the machine if there are no cutting tools or sharp objects in it, or if these are covered.
- Never move body parts under parts in the working area of the machine with the potential to drop down.



WARNING

Serious injuries caused by snagging body parts on the rotating machine spindle!

- Never reach into the product while the machine spindle is still rotating.
- Before working on the product, ensure that the machine spindle is unable to start up.



WARNING

Serious injuries caused by reaching into slots and bores!

- Never reach into slots or bores.



WARNING

Serious injuries caused by workpieces dropping or the clamping unit getting released!

- Only unclamp the workpiece if it is protected against falling.



WARNING

Serious injuries caused by the use of damaged products or by their components and accessories!

- Check products or their components and accessories on a regular basis for visible signs of damage [see »Inspections« and »Cleaning« chapters].
- Use of damaged products, their damaged components and/or their damaged accessories is prohibited.
- Report damage to the operator immediately.
- Damaged components / accessories must be replaced with genuine spare parts / accessories made by the manufacturer.



CAUTION

Cut injuries caused by sharp edges and burrs resulting from wear and/or repeated rework!

- Remove sharp edges and burrs.
- If necessary, replace worn components with genuine parts made by the manufacturer.



NOTE

Serious damage to materials / the machine tool / the product caused by workpieces being ejected centrifugally if clamping is released while they are still rotating!

- Never release the clamping of the workpiece while it is still rotating.



NOTE

Damage to materials caused by untightening the wrong screws!

- Do not open the screws secured with sealing lacquer.

2.7 Screws



WARNING

Serious injuries caused by radially installed screws being ejected centrifugally if installed incorrectly / poor handling!

- Do not open the screws secured with sealing lacquer.
- Screws and threaded pins fitted radially to the product that were bonded with adhesive need to be secured again using a standard, medium-strength screw adhesive and tightened to the specified tightening torque [see nomenclature or the »Screw tightening torques« chapter]. Before reinstallation, clean and degrease the screw and internal thread.
- Radially mounted screws and threaded pins that were not bonded with sealing lacquer or an adhesive need to be tightened back down to the specified tightening torque [see nomenclature or the »Screw tightening torques« chapter].
- If in doubt, contact the manufacturer immediately to determine how best to proceed.

2.8 Functionality



WARNING

Serious injuries caused by severe contamination of the product!

- Always comply with the cleaning instructions and intervals [see »Cleaning« chapter].

2.9 Environmental protection



NOTE

Substantial damage to the environment can result from non-compliant handling or incorrect disposal of environmentally hazardous substances!

- If environmentally hazardous substances enter the environment accidentally, take immediate remedial action.
- If in doubt, notify the relevant municipal authorities about the incident.

The following environmentally hazardous substances are used:

Lubricants, auxiliary materials and operating fluids

Lubricants such as grease and oil can contain toxic substances. These must not enter the environment.

Dispose of environmentally hazardous substances properly [see »Disposal« chapter].

3 Technical data

3.1 General information

Size	Clamping range [mm]	Axial release stroke [mm]	Axial clamping reserve [mm]	Radial opening stroke in Ø [mm]	Radial reserve stroke in Ø [mm]	Total weight [kg]	Spindle flange weight [kg]	Functional unit weight [kg]	Dimensions [Ø x length] [mm]	Maximum speed [min^{-1}]	Axial clamping force $F_{ax\ max}$ [kN]	Radial clamping force $F_{rad\ max}$ [kN]	Balancing quality G in n planes
A	18-24	2.0	2.0	0.18	0.26	7.7-37.5	3.0-32.8	4.7	Ø 140.0-230.0 x 140.0-275.0	7000	7.5	27	10/1
B	20-32	2.0	2.0	0.17	0.26	8.1-37.9	3.0-32.8	5.1	Ø 140.0-230.0 x 140.0-275.0	7000	10	36	10/1
C	24-39	2.0	2.0	0.26	0.4	7.8-37.6	3.0-32.8	4.8	Ø 140.0-230.0 x 150.0-285.0	7000	16	51	10/1
D	32-50	2.5	2.0	0.32	0.4	8.5-38.3	3.0-32.8	5.5	Ø 140.0-230.0 x 170.0-305.0	7000	22	70	10/1
E	39-68	2.5	2.0	0.3	0.4	9.1-38.9	3.0-32.8	6.1	Ø 140.0-230.0 x 180.0-315.0	7000	27	86	10/1
F	50-100	2.5	2.0	0.3	0.4	9.4-39.2	3.0-32.8	6.4	Ø 140.0-230.0 x 180.0-315.0	6000	45	143	10/1

Table 1: Technical data



INFORMATION

$F_{rad\ max}$ can only be reached in lubricated condition. In unlubricated condition, $F_{rad\ max}$ is much less.

3.2 Performance values



NOTE

Material damage to the products use and/or to the machine tool caused by exceeding the maximum performance values!

- Do not exceed the maximum performance values [see »General information« chapter].
- On all products used, do not exceed the lowest of the maximum performance values.
- Only use product in machine tools with the same performance values.



INFORMATION

Details of maximum performance values can be found on each product.

If, due to abrasive wear, those performance values are no long legible, refer to the operating instructions.

The achievable actuation forces may vary as a result of the maintenance status [lubrication status and level of contamination] of the product [see »Maintenance schedule« chapter].

The achievable clamping forces resulting from actuating forces must be checked at regular intervals. For this, structural clamping force measurements must be performed.

3.3 Balancing quality

The product is balanced before leaving the factory [balancing quality - see »General information« chapter].



DANGER

Serious injuries caused by parts being ejected centrifugally if products are not balanced correctly!

- Do not clamp rotationally symmetrical workpieces, or do so only after contacting the manufacturer.
- Never remove balancing screws and weights attached to the product.



NOTE

Material damage caused by machining with incorrectly balanced products!

- Do not clamp rotationally symmetrical workpieces, or do so only after contacting the manufacturer.
- Never remove balancing screws and weights attached to the product.

3.4 Speed

The product is authorized for rotational operation.

The maximum speed is written on the product [maximum speed, see »General information« chapter].



DANGER

Serious injuries caused by parts being ejected centrifugally due to a non-compliant combination of several products!

- From all of the maximum speeds indicated for the combined products, always remain at the lowest of those maximum speeds.



DANGER

Serious injuries caused by workpieces being ejected centrifugally after a loss of clamping power!

- Never rotate the product without a workpiece installed.
- When several clamping points are involved, clamp a suitable workpiece to each one.
- If necessary, adjust the machining forces.

3.5 Operating conditions

Indication	Value	Unit
Ambient temperature range	15 - 65	°C
Workpiece temperature	≤ 80	°C
Humidity	≤ 80	%

Table 2: Operating conditions

3.6 Type designation

The type designation is on the product and it includes the following indications:

- Manufacturer
- Product designation
- ID number [marked with a # symbol]
- Build year
- Maximum speed n [min^{-1}]
- Maximum actuating force $F_{ax\ max}$ [kN]
- Maximum clamping force $F_{rad\ max}$ [kN]

4 Layout and function

4.1 Overview and brief description

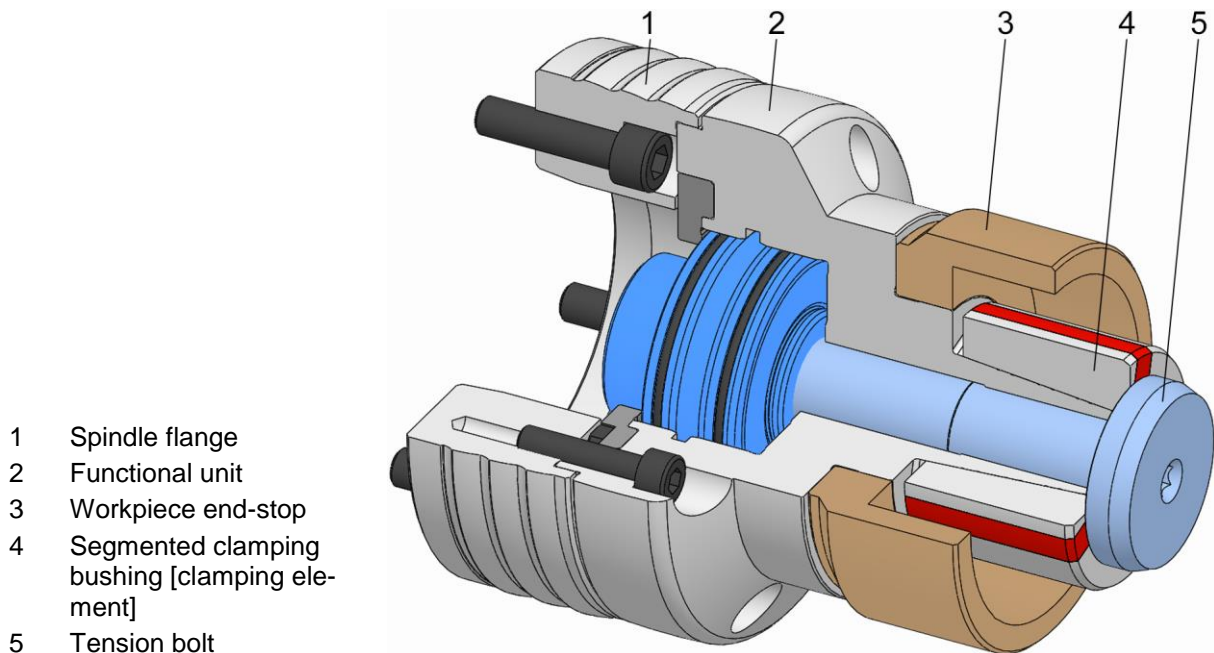

The spindle flange is mounted on the machine spindle.

The clamping device is screwed to the drawtube on the machine tool through the drawtube adapter and is screwed to the spindle flange.

The clamping element is mounted to the clamping device with the tension bolt and the workpiece end-stop, and it clamps the workpiece that is to be machined.

The workpiece end-stop is secured to the clamping device.

The clamping device functions on the pull-back principle.

When clamping, the clamping element performs an axial movement towards the workpiece end-stop.

The mobile coupling draws the clamping element onto the stationary taper.

This draws the workpiece firmly up against the stationary workpiece end-stop.

This increases the rigid strength of this clamping configuration.

4.2 Accessories required

4.2.1 Spindle flange

The spindle flange helps to adapt the clamping device to suit the machine tool.

Depending on the scope of delivery, the spindle flange can either be supplied with the unit or provided by the customer.

4.2.2 Drawtube adapter

The drawtube adapter serves as a connector between the drawtube on the machine tool and the clamping device and, depending on the type of machine, can be configured in various forms.

4.2.3 Segmented clamping bushing

The segmented clamping bushing is manufactured with a customer-specified clamping diameter.

4.2.4 Workpiece end-stop

The workpiece end-stop is produced with an end-stop dimension that reflects customer wishes.

4.3 Optional accessories

The following optional accessories are available for different sizes of product.

4.3.1 Adapter for checking the air system

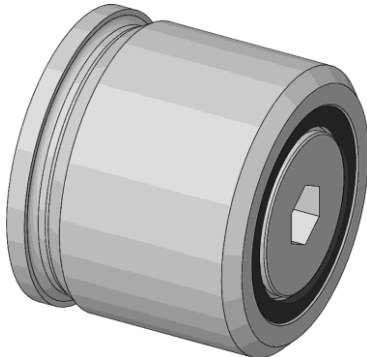

Using the adapter makes it possible to operate the product with an air system check.

4.3.2 hs dock actuating unit

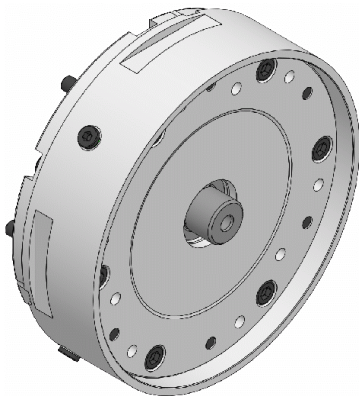

The actuating unit is used for pneumatic and hydraulic actuation of the MANDO segmented mandrels.

4.3.3 Rotating ms dock actuating unit

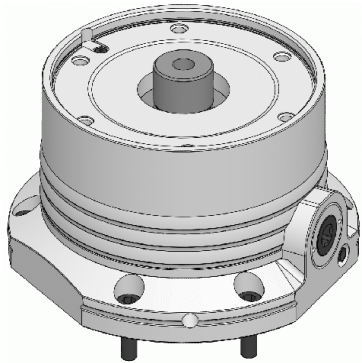

The actuating unit is used for manual actuation of the MANDO segmented mandrels.

4.3.4 ms dock stationary actuating unit

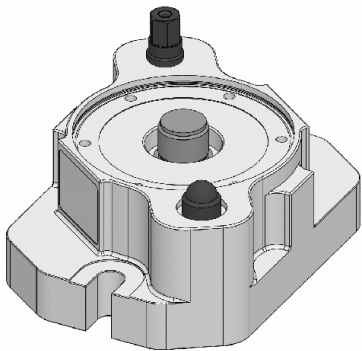

The actuating unit is used for manual actuation of the MANDO segmented mandrels.

5 Use and limits of use

5.1 Use

The product is a clamping device that may only be used to clamp a rotationally symmetrical workpiece to enable it to be machined.

As well as for its general field of application, this product was designed and developed for use, when necessary, in a specific and documented application [see clamping situation drawing or order confirmation].

Any other fields of application require the explicit approval of the manufacturer.

The clamping device is used for the internal clamping of workpieces.

As standard equipment, the clamping device is prepared with channels for checking the air system and it can be connected to the media supply on the machine with an additional adapter.

The force-actuated clamping device can also be actuated manually or hydraulically using a suitable actuating unit.

5.2 Limits of use

Limits are set on the operation of segmented mandrels in the area where workpieces are machined.

5.2.1 Nomenclature

Brief designation	Unit	Explanation
F_z	N	Centrifugal force
m	kg	Mass of the segmented clamping bushing
$m_{w\ max}$	kg	Maximum workpiece mass
r_s	m	Distance between mass center of gravity of segmented clamping bushing and rotational axis of the segmented mandrel

Table 3: Nomenclature application limits

5.2.2 First limit [workpiece length]

To assist with clamping of the workpiece when working with very long workpieces, a tailstock or a back rest.

5.2.3 Second limit [workpiece mass]

The maximum workpiece mass depends on the width across flats and/or on the inner circle diameter of the mandrel tip on the product.

Width across flats range and/or inner circle diameter of mandrel tip [mm]	Standard size	Maximum workpiece mass $m_{w\ max}$ [kg]	
		Horizontal application	Vertical application
≤3.5		0.5	0.7
> 3.5 to ≤ 4.5		3	5
> 4.5 to ≤ 7.0		6	8
> 7.0 to ≤ 10.5	A	12	18
> 10.5 to ≤ 13	B	25	37
> 13 to ≤ 16.5	C	32	50
> 16.5 to ≤ 20.0	D	40	52
> 20.0 to ≤ 25.0	E	50	65
> 25.0 to ≤ 32.0	F	60	80
> 32.0 to ≤ 45.0		80	100
> 45.0 to ≤ 70.0		100	150

Table 4: Maximum workpiece mass

5.2.4 Third limit [clamping length]

The clamped length must be proportional to the planned clamping and machining operation.

5.2.5 Fourth limit [forces]

The radial clamping force must exceed its required limit.

The required level of radial clamping force required is derived from the planned cutting conditions and the resultant machining forces and torques.

As the clamping element mass increases, a higher level of centrifugal force needs to be taken into account when selecting the clamping force.

The centrifugal force can be determined on the basis of the following formula:

$$F_z = \left(\frac{\pi * n}{30}\right)^2 * m * r_s$$

Simultaneous machining, for example through the use of several tools, also need to be superimposed technically in regard to forces. This involves taking account of the highest forces and the least favorable torques involved in the machining process.

The clamping forces must be adapted to reflect the workpiece materials.

The torque exerted on the clamping device during machining of the workpiece must never exceed the maximum level of transmissible torque resulting from the radial clamping force.

6 Transport, packaging, storage

6.1 Safety, transport, packaging, storage



WARNING

High level of physical strain due to the weight of the product or of its components if not transported properly!

- From a weight of 10 kg, use appropriate transport equipment, lifting gear and lifting tackle.



WARNING

Serious crushing injuries and breakages caused by falling parts if transported incorrectly!

- Ensure that the product cannot roll away or fall.
- Place on a non-slip surface.
- When using lifting gear, use appropriate load-bearing equipment and lifting tackle.



WARNING

Serious injuries caused by transporting off-center equipment!

- Pay attention to marks on the packaging items.
- Attach the crane hook directly above the center of gravity.
- Raise carefully and correct the lifting points if necessary.



WARNING

Serious injuries caused by incorrect transport with lifting gear!

- Never raise loads above people.
- Never step under suspended loads.
- Pay attention to information about the intended lifting points. Ensure that the lifting gear is mounted on a secure base.
- Only use authorized and undamaged lifting gear, load-bearing equipment and lifting tackle.
- Never exceed the maximum load-bearing capacity of lifting gear, load-bearing equipment and lifting tackle.



NOTE

Damage to materials caused by falling parts if transported incorrectly!

- Ensure that the product cannot roll away or fall.
- Place on a non-slip surface.
- When using lifting gear, use appropriate load-bearing equipment and lifting tackle.

6.2 Symbols on the packaging



Fragile

Designates packaging items with fragile or breakable contents.

Handle the packaging item with care. Do not drop it and protect it against collision impacts.



Keep it dry

Keep packaging items dry and protect them from the ingress of water.



Position designation

Points to the correct upright position of the packaging item.

6.3 Transport inspection

Check the delivery on receipt immediately to ensure it is complete and has not been damaged in transit.

Proceed as follows if you find any externally visible signs of damage while in transit:

- Refuse to accept the delivery, or only subject to later approval
- Make a note of the extent of damage on the transportation documents or on the delivery note of the transportation company
- Initiate a complaint



INFORMATION

Raise a complaint for every defect as soon as it is discovered. Compensation claims can only be enforced during the applicable complaint periods.

6.4 Unpacking and internal transportation

The total weight of the product depends on its size.

Depending on the weight involved, it may be necessary to use lifting gear to lift the product or its components out of the packaging safely, to transport them and to position and install them in the machine tool or on the machine table.

1. The product is packaged in a stable position, and it has threads / bores for transportation.
2. Lifting tackle can be installed in these transportation threads / bores. To lift the product out of its packaging, the front-end functional threads can if necessary be used to attach lifting tackle to upright packaged products.
3. Attach load-bearing equipment to the lifting tackle.
4. Subject to weight, use lifting gear to lift the product out of its packaging safely, and place it down on a stable, flat surface.
5. Secure the product to prevent it from rolling away.
6. When transporting on a trolley or car, ensure that the product is securely mounted on a non-slip surface before starting to move it.

6.5 Packaging

The individual packaging items are packaged in an appropriate manner for the type of transportation involved. Always use environmentally compatible materials for packaging purposes.

Packaging should protect individual components from damage in transit, corrosion and other forms of damage, up until installation. For this reason, do not destroy the packaging, and do not remove it until shortly before installation.



INFORMATION

The packaging units are packaged, wrapped in airtight film and placed in cardboard boxes. On the individual weights of each of the sizes [see »General information« chapter].

Dispose of packaging material in accordance with applicable legislative provisions and local regulations.



NOTE

Damage to the environment caused by improper disposal of packaging materials!

- Dispose of packaging materials in an environmentally responsible manner.
- Pay attention to local disposal regulations and, if necessary, appoint a specialist waste disposal company with this work.

6.6 Storage



INFORMATION

The packaged items may display information relating to storage and readmission to storage that extend beyond the scope of these requirements. Pay attention to these notices.

Store packaged items under the following conditions:

- Safe for storage.
- Do not store outdoors.
- Store in a dry, dust-free place.
- Avoid exposure to aggressive media.
- Protect against direct sunlight.
- Avoid mechanical vibration.
- Storage temperature: 15 to 35°C.
- Relative humidity: Maximum 60%.
- In the event of storage for more than 3 months:
 - On a regular basis, check the general condition of all parts and packaging.
 - If necessary, refresh the preservation or replace it.

6.7 Preservation

1. Clean and lubricate the product [see »Cleaning« and »Lubricating the product« chapters].
2. Apply a light coating of preserving oil to the inner and outer faces of the product. Wipe away surplus preserving oil with a soft, lint-free, tear-resistant cloth.
3. Pack product air-tight in foil.
4. Return product to storage [see »Return to storage« chapter].

6.8 Return to storage

Return product to storage under the following conditions:

1. Preserve the product [see »Preservation« chapter].
2. The product must be stored in a safe condition. Use an appropriate container for the product, on a non-slip surface, or fit the floor of the shelving unit with an all-round safety border.
3. For storage conditions, see the »Storage« chapter.

7 Installation

7.1 Installation safety



WARNING

Serious injuries caused by unskilled staff during installation / removal!

- Installation and removal must be performed by skilled staff from the relevant specialist field.



WARNING

Serious injuries can be caused if the machine tool starts up accidentally!

- Set the machine tool into set-up mode.
- Remove all tools, auxiliary equipment and items of test equipment immediately from the working area of the machine.
- Remove all lifting gear from the product and from the working area of the machine.



WARNING

Serious injuries caused by the escape of media under high pressure!

- Shut down media delivery during installation and removal.
- Relieve any pressure trapped in the system.
- Shut down the system.



WARNING

Serious crushing injuries and breakages caused by falling parts during incorrect installation or removal!

- Ensure that the product cannot roll away or fall.
- If necessary, use an appropriate mounting aid for installation or removal on a vertically suspended machine spindle.



WARNING

Serious crushing injuries caused by improper machine movement during installation or removal!

- Machine movements are only permitted in set-up mode during installation and removal.
- Never reach into a gap.
- Pay attention to the gap dimensions of moving parts.



WARNING

Serious head injuries caused by bending into the working area of the machine!

- Only ever bend into the working area of the machine if there are no cutting tools or sharp objects in it, or if these are covered.
- Never move body parts under parts in the working area of the machine with the potential to drop down.
- Depending on weight, use an appropriate mounting aid for installation or installing on a vertically suspended machine spindle.



WARNING

High level of physical strain due to the weight of the product or of its components if not transported properly!

- From a weight of 10 kg, use appropriate transport equipment, lifting gear and lifting tackle.



CAUTION

Serious cut injuries caused by sharp-edged changing parts and/or clamping elements!

- All installation / removal of changing parts and clamping elements must be performed by skilled staff from the relevant specialist field.



NOTE

Damage to materials caused by lifting gear left in the product!

- Always remove lifting gear immediately after installing the product.



NOTE [only for aluminum components]

Damage to materials can be caused by incorrect screw tightening torques on aluminum components!

- Pay attention to the reduced screw tightening torques for aluminum components [see »Screw tightening torques« chapter].

7.2 Preliminary remarks

- In accordance with their thread size and strength class, screws must be tightened crosswise to the specified tightening torque [see »Screw tightening torques« chapter]. When tightening the screws, do so evenly to prevent any distortion under load.
- To avoid precision errors, clean all screw-fitting points and mating surfaces [Notes on cleaning, see »Cleaning« chapter]. Factory wetting of flat surfaces and, where necessary of clamping elements, only serves as a corrosion inhibitor. This is not functionally related lubrication.
- Only apply lubricant to the mechanical mating surfaces. Pay attention to notes about lubricants [see »Use of lubricants« chapter].
- Avoid too much lubricant on the locating face because this can cause face run-out errors.
- Apply grease to the sealing elements [for example O-rings, rectangular rings] and sealing surfaces. Pay attention to notes about greases [see »Use of lubricants« chapter].
- Do not damage the functional surfaces [flat, mating, tapered and sealing surfaces].

7.3 Screw tightening torques

The tables show the specified values.

Knowledge of the applicable guidelines and design criteria is essential.



NOTE

Damage to materials caused by defective screw tightening torques!

- To secure the product to the machine, pay attention to the values specified by HAINBUCH and by the machine manufacturer for screw tightening torques. If the machine manufacturer stipulates different values, you must consult HAINBUCH.

Metric control threads

The following table contains the guide values in Nm for screw tightening torques for achieving the highest permitted pre-load for metric control threads.

- Total friction coefficient $\mu_{ges} = 0.12$

Thread designation	Tightening torque at screw quality [Nm]	
	10.9	12.9
M4	4	5
M5	7	9
M6	12	15
M8	25	38
M10	50	70
M12	100	130
M16	220	300
M20	400	550
M24	600	800

Table 5: Screw tightening torques, metric control threads

Aluminum components

The following table contains the reduced screw tightening torques for securing aluminum components.

Thread designation	Tightening torque [Nm]	Minimum screw depth [mm]
M6	10	12
M8	23	16
M10	46	20

Table 6: Screw tightening torques for aluminum components

7.4 Preparation of the machine for installation

1. Set the machine into set-up mode.



INFORMATION

The minimum operating pressure is reached when the drawtube can still just be moved without triggering an error message.

2. Reduce the operating pressure to a minimum.
3. Remove cutting tools and/or sharp objects from the working area of the machine, or cover them.

7.5 Installation of the product

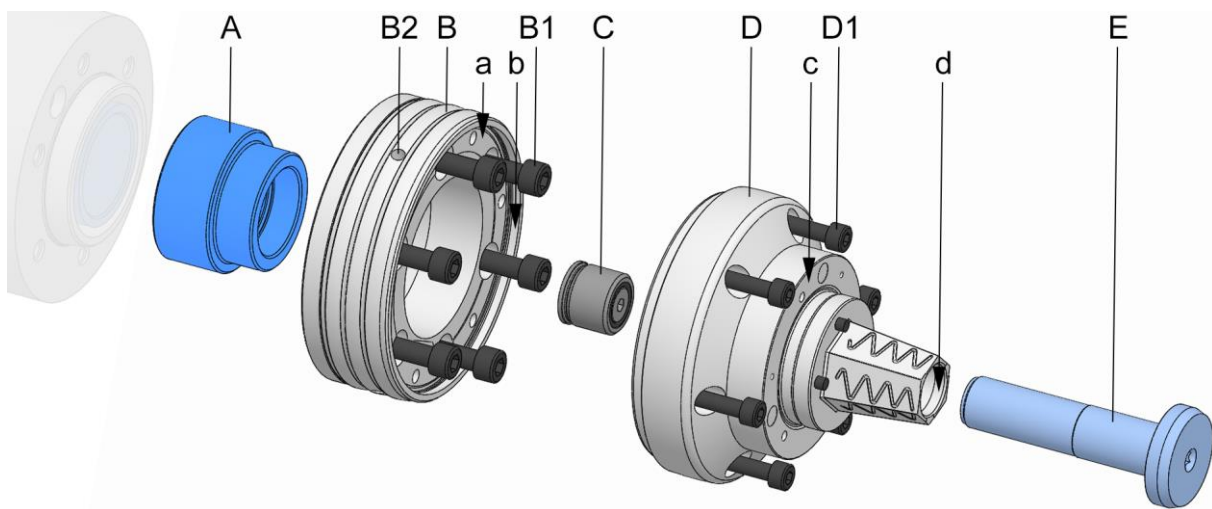

- A Drawtube adapter
- B Spindle flange
- B1 Fixing screws, spindle flange
- B2 Transport thread spindle flange
- C Adapter for checking air system
- D Functional unit
- D1 Fixing screws on functional unit
- E Tension bolt
- a Test surface face run-out spindle flange
- b Test surface axial run-out spindle flange
- c Test surface face run-out functional unit
- d Test surface axial run-out functional unit

1. As described in the »Preparation of the machine for installation« chapter, prepare for the following steps.

7.5.1 Compatibility check

Check the compatibility of the product and the connection point of the machine.

For this, check that the connection point and the product share the same adaptation geometry. Also check if the actuating element / coupling element is suitable.

It may be necessary to install an adapter between the actuating element on the machine and the product.

7.5.2 Preparation of the product

The product is supplied in assembled condition.

The following preparatory steps are needed to install the product.

If the prepared air system check on the product is not to be used, continue with a check of the spindle flange and/or the drawtube adapter.

The following preparatory steps are needed to install the product if the prepared air system check of the product is to be used.



INFORMATION

The adapter for the air system check can only be used if it is connected to the machine, if necessary with a drawtube adapter fitted to the external thread of the product.

It may be necessary to remove a drawtube adapter fitted previously in order to install the adapter for the air system check.

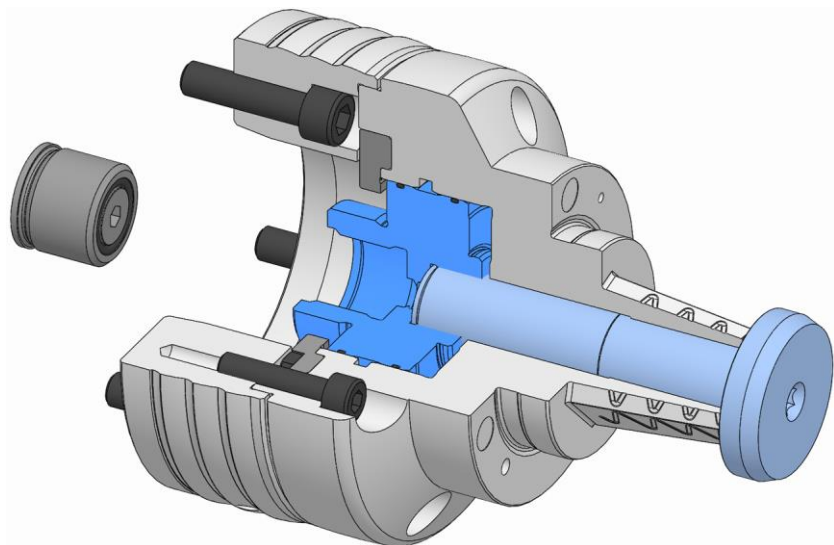

NOTE

Damage to materials caused by incorrect installation of sealing elements!

- Replace missing or damaged sealing elements.
- Ensure that the sealing elements do not fall out or get damaged during installation / removal, and apply a thin coat of grease if necessary.

1. If necessary, screw the adapter for the air system check into the product.

If the spindle flange and / or the drawtube adapter is included in the scope of delivery, the following preparatory steps are needed to install the product.

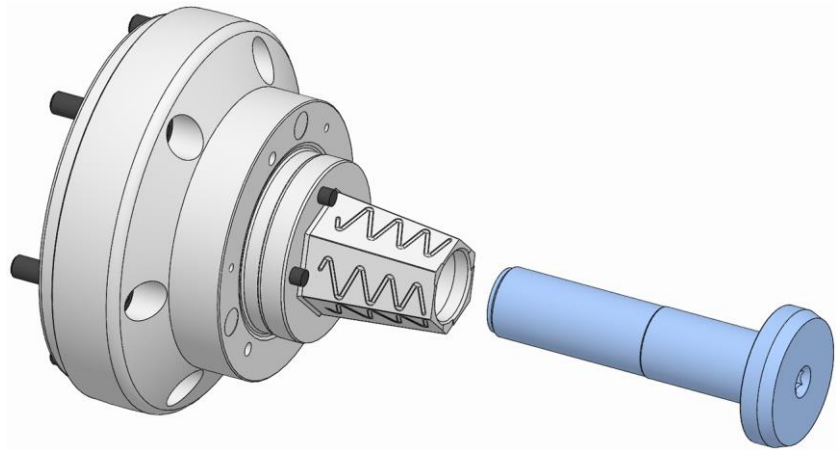

1. Unfasten and remove the tension bolt.

If the spindle flange and / or the drawtube adapter is installed on the clamping device, the following preparatory steps are needed to install the product.



INFORMATION

The drawtube adapter may already be installed in the clamping device.

Depending on the geometry of the drawtube adapter, it may be necessary to remove the drawtube adapter to be able to dismantle the functional unit from the spindle flange.

1. If necessary, unscrew and remove the drawtube adapter from the product.

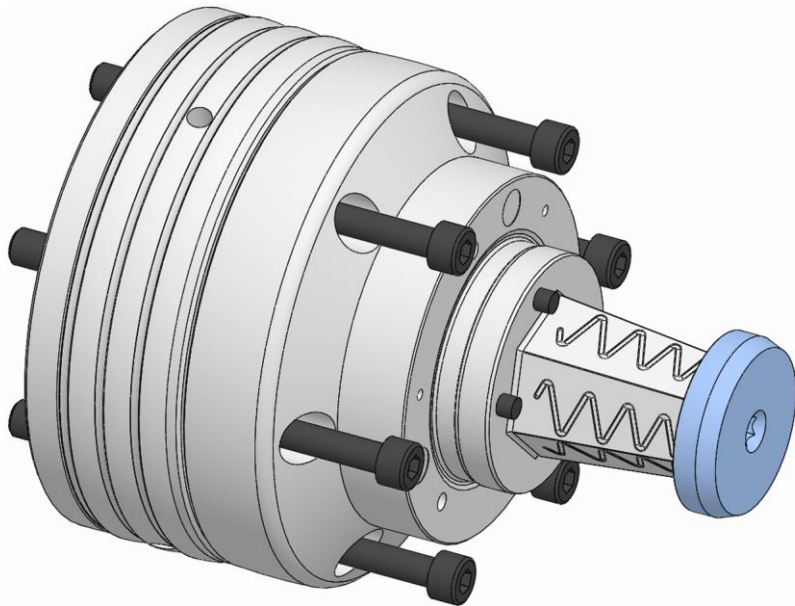

2. Unfasten and remove the fixing screws on the functional unit.



INFORMATION

To install the functional unit on the machine, you need to know if this product can or cannot be aligned.

Check the order confirmation. If the clamping device can be aligned, the order confirmation will have a note to this effect.

And/or check if there is clearance at the interface between spindle flange and functional unit. For this, slide the spindle flange and functional unit together. If the functional unit can be moved in the spindle flange, the clamping device can be aligned.

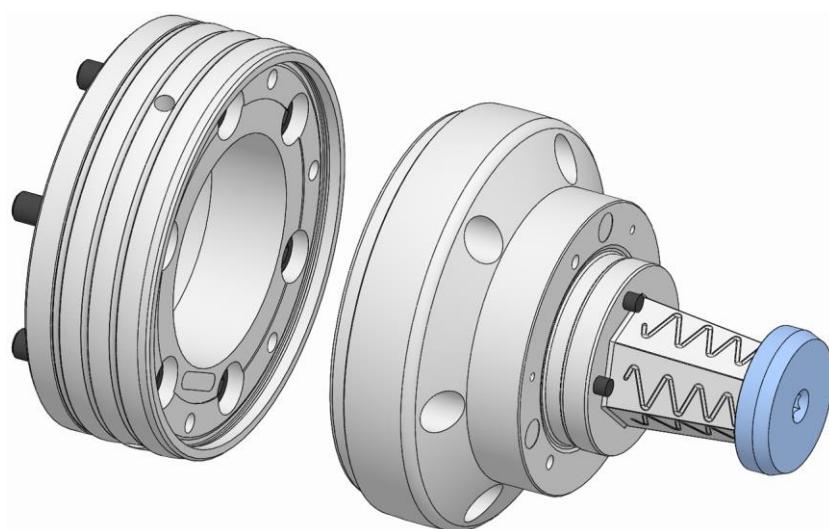

3. Take down the functional unit from the spindle flange.

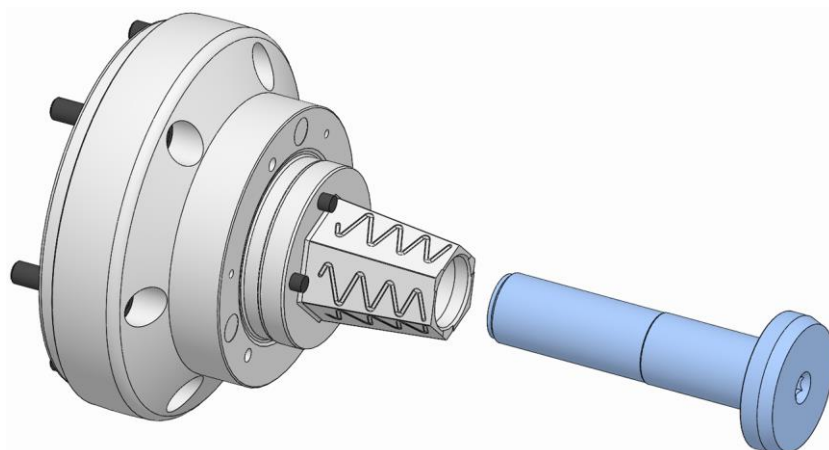

4. Unfasten and remove the tension bolt.

7.5.3 Installation of the product on an actuating unit



INFORMATION

Installation / removal of the product is described in the operating instructions for the actuating unit.



In addition to these operating instructions, you should also read and follow the operating instructions for the actuating unit.

1. Install the product.

If a clamping element is to be installed, proceed with installation of the clamping element [see »Installation of the clamping element« chapter].

If no clamping element is to be installed, the following steps are required.

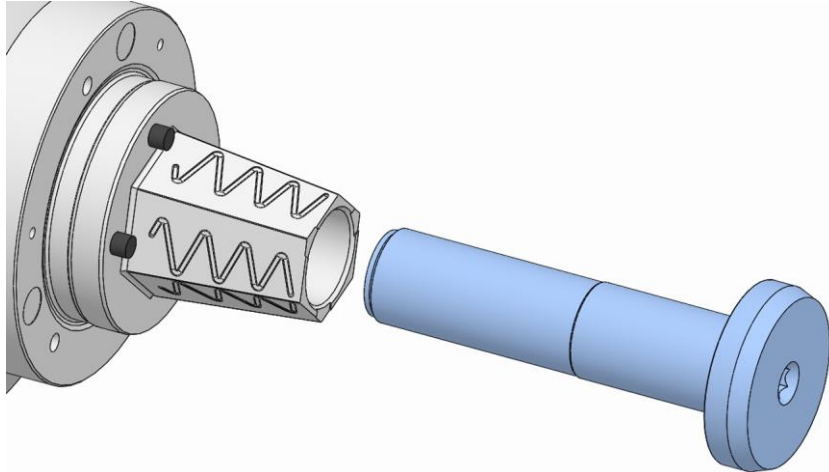

WARNING

Serious injuries caused by tension bolt being ejected centrifugally if tightening torque is incorrect!

- Always tighten the tension bolt down into the product and tighten to the specified tightening torque [see nomenclature].

2. Screw the tension bolt into the product and tighten to the specified tightening torque [see nomenclature].

7.5.4 Installation of the drawtube adapter



INFORMATION

Depending on the geometry of the drawtube adapter, it must be installed either on the machine drawtube or in the functional unit.

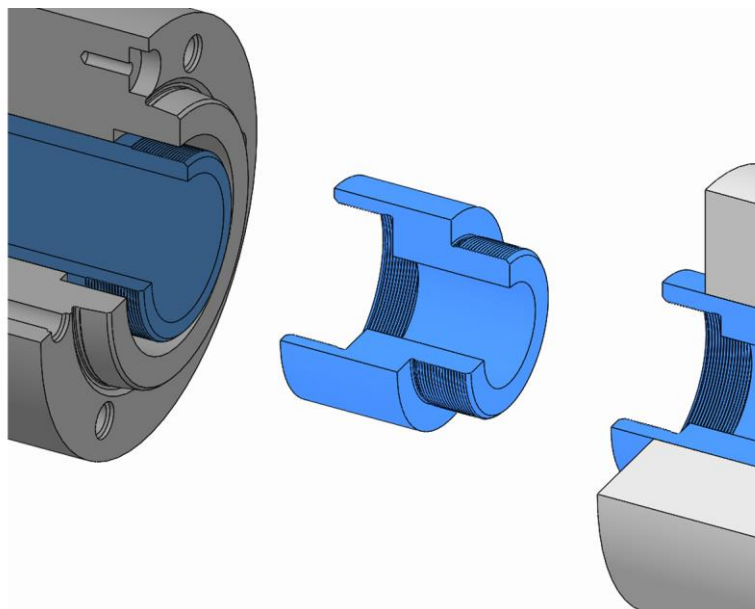

1. Screw the drawtube adapter into the functional unit using its thread or screw it to the machine drawtube and tighten it down.

7.5.5 Installation of a spindle flange that cannot be aligned

1. Attach any lifting gear that may be required.
2. If necessary, fit the mounting aid onto a vertically suspended spindle.

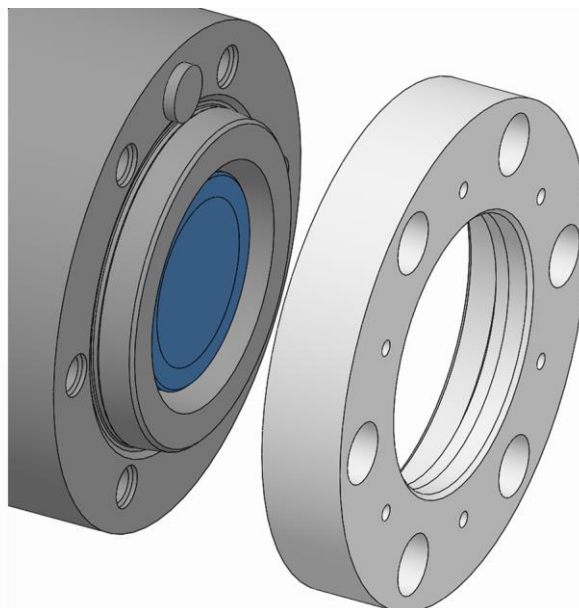
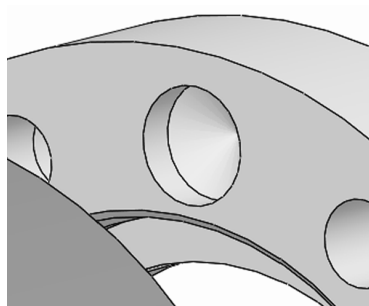



INFORMATION

The positioning block on the machine spindle and the positioning bore in the spindle flange can be used for positioning.

3. Fit the spindle flange on the machine spindle. If necessary, position the spindle flange over the machine spindle using its bore.

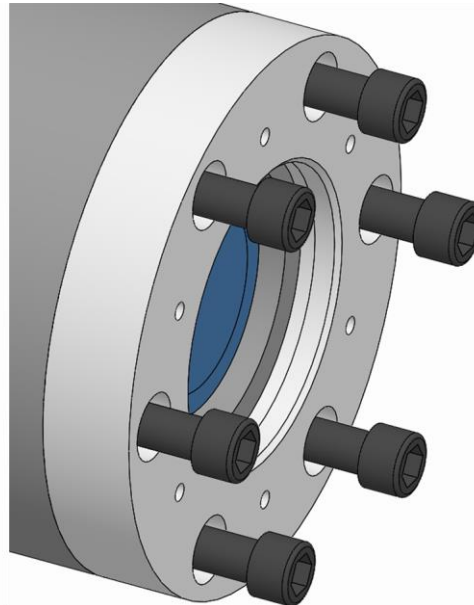

4. Screw in the changing part fixing screws on the spindle flange and tighten to the specified tightening torque [see »Screw tightening torques« chapter].
5. Unfasten and remove any lifting gear that may have been required.
6. Remove the mounting aid on a vertically suspended spindle if one was used.
7. Check face run-out on the test surface of the spindle flange [ideally ≤ 0.005 mm].
8. Check axial run-out on the test surface of the spindle flange [ideally ≤ 0.005 mm].

Whenever the face run-out and/or the axial run-out is greater than the maximum permitted value:

9. Remove the spindle flange.
10. Clean the locating face and the mating faces of the machine spindle and the spindle flange.
11. If there is a burr or slight damage, rub down the locating face of the spindle flange and the machine spindle gently with an oil stone.
12. Reinstall the spindle flange.
13. Repeat the face run-out test.
14. Repeat the axial run-out test.

7.5.6 Installation of a spindle flange that can be aligned

1. Attach any lifting gear that may be required.
2. If necessary, fit the mounting aid onto a vertically suspended spindle.

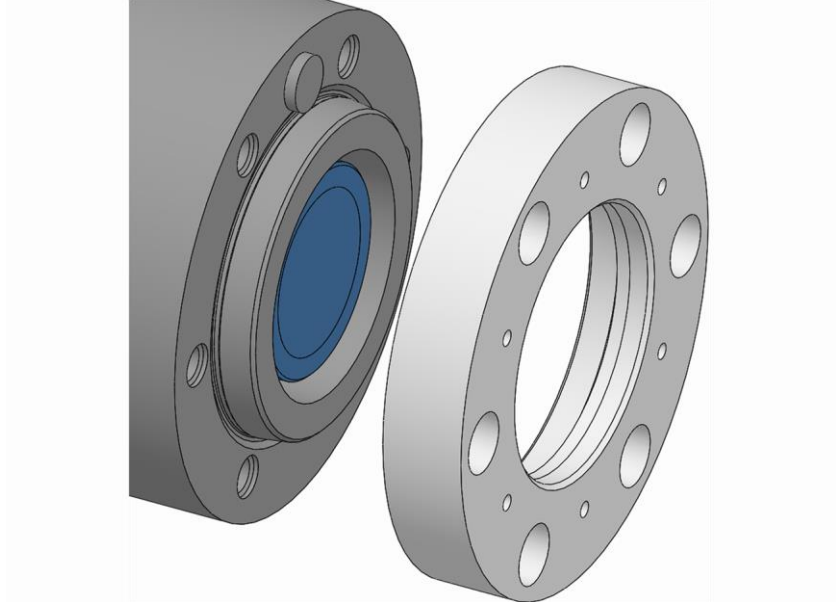
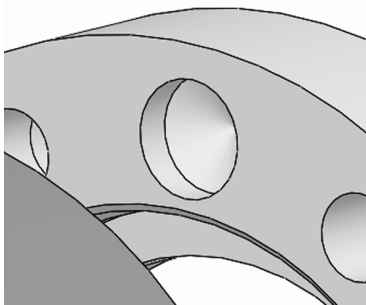

INFORMATION

The positioning block on the machine spindle and the positioning bore in the spindle flange can be used for positioning.

3. Fit the spindle flange on the machine spindle. If necessary, position the spindle flange over the machine spindle using its bore.

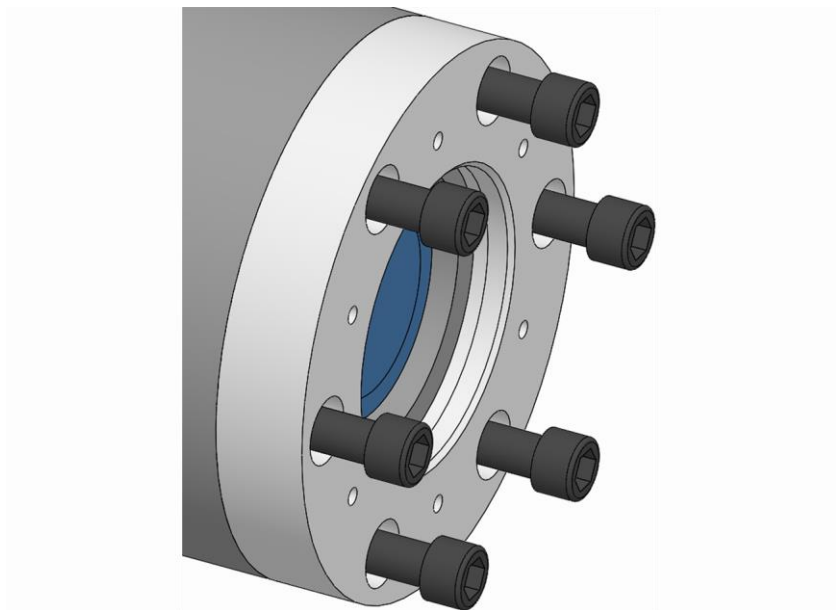

4. Screw in the spindle flange fixing screws and tighten them gently.

5. Unfasten and remove any lifting gear that may have been required.
6. Remove the mounting aid on a vertically suspended spindle if one was used.
7. Check the face run-out on the test surface of the spindle flange [ideally ≤ 0.005 mm] and, if necessary, correct carefully with a plastic hammer.

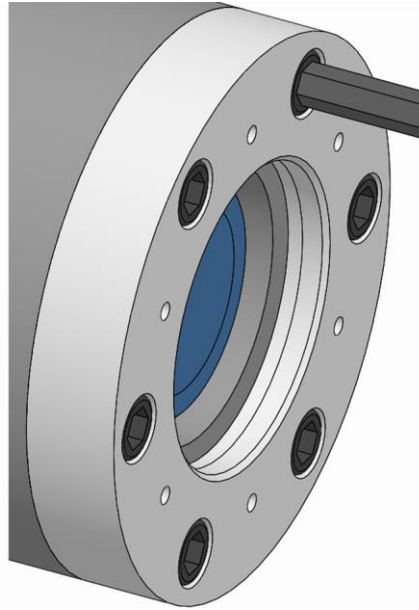

8. Screw in the drift body fixing screws on the spindle flange and tighten to the specified tightening torque [see »Screw tightening torques« chapter].
9. Check face run-out on the test surface of the spindle flange [ideally ≤ 0.005 mm].

Whenever the face run-out is greater than the maximum permitted value:

10. Remove the spindle flange.
11. Clean the locating face and the mating faces of the machine spindle and the spindle flange.
12. If there is a burr or slight damage, rub down the locating face of the spindle flange and the machine spindle gently with an oil stone.
13. Reinstall the spindle flange.
14. Repeat the alignment process.
15. Repeat the face run-out test.

7.5.7 Installation of the functional unit of an alignable clamping device

1. Attach any lifting gear that may be required.
2. If necessary, fit the mounting aid onto a vertically suspended spindle.
3. Move the machine drawtube to the front limit stop.

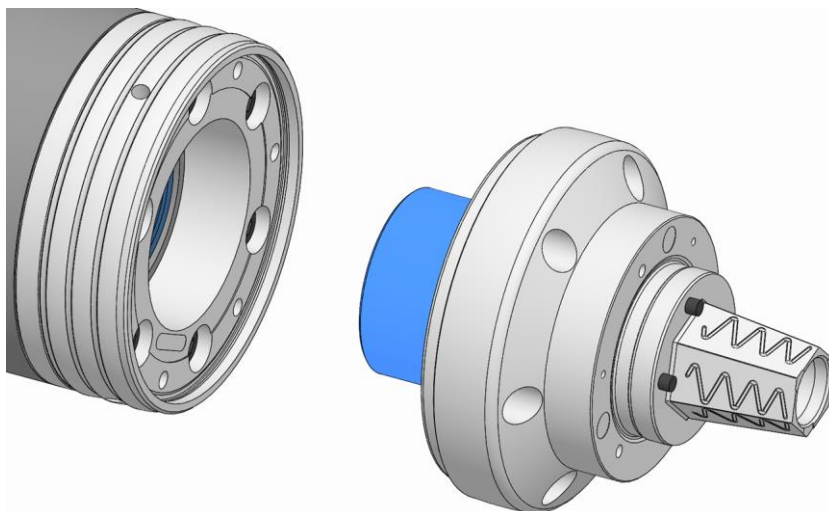

NOTE

Damage to materials caused by incorrect installation when using the adapter to check the air system!

- Ensure that the sealing elements do not fall out or get damaged during installation, and apply a thin coat of grease if necessary.



INFORMATION

If lifting gear needs to be used, rotate the spindle flange and machine spindle manually to tighten / un-tighten the functional unit.

4. Screw the functional unit firmly home on the machine drawtube.

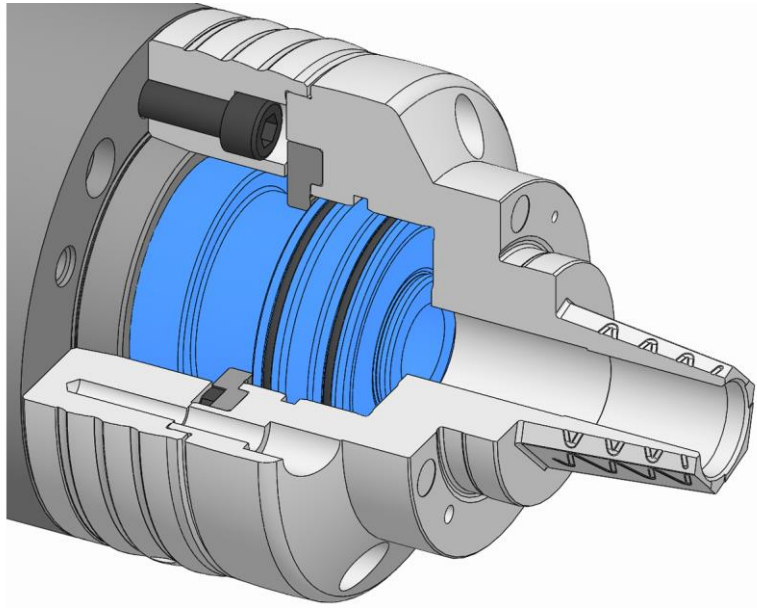

5. Turn back the functional unit until the hole patterns on the spindle flange and functional unit are aligned.



WARNING

Serious crushing injuries caused by improper machine movement during installation!

- Never reach into the gap between machine tool, spindle flange and functional unit.

6. Using the least possible force and speed, move the drawtube on the machine to its front limit stop [see »Preparing the machine for installation« chapter].

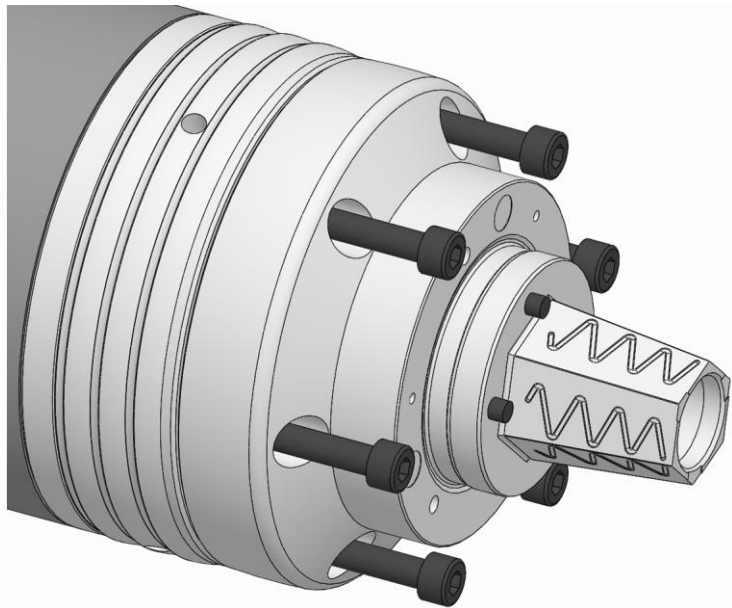

7. Screw in the fixing screws on the functional unit and tighten them gently.
8. Unfasten and remove any lifting gear that may have been required.

9. Remove the mounting aid on a vertically suspended spindle if one was used.
10. Check the face run-out on the test surface of the functional unit [ideally ≤ 0.003 mm] and, if necessary, correct carefully with a plastic hammer.

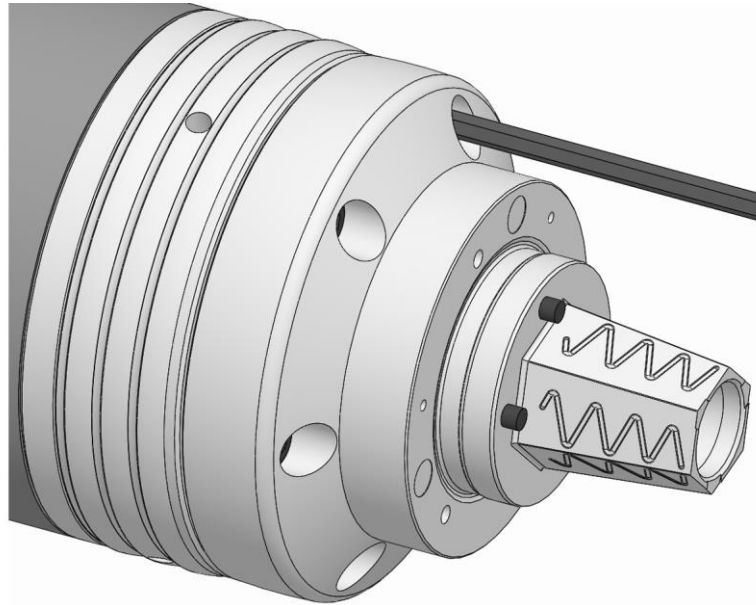

11. Tighten the fixing screws on the functional unit to the specified tightening torque [see »Screw tightening torques« chapter].
12. Check face run-out on the test surface of the functional unit [ideally ≤ 0.01 mm].

Whenever the face run-out is greater than the maximum permitted value:

13. Remove the functional unit.
14. Clean the locating face and the mating faces of the spindle flange and the functional unit.
15. If there is a burr or slight damage, rub down the locating face of the spindle flange or the functional unit gently with an oil stone.
16. Reinstall the functional unit.
17. Repeat the alignment process.
18. Repeat the face run-out test.

If a clamping element is to be installed, proceed with installation of the clamping element [see »Installation of the clamping element« chapter].

If no clamping element is to be installed, the following steps are required.

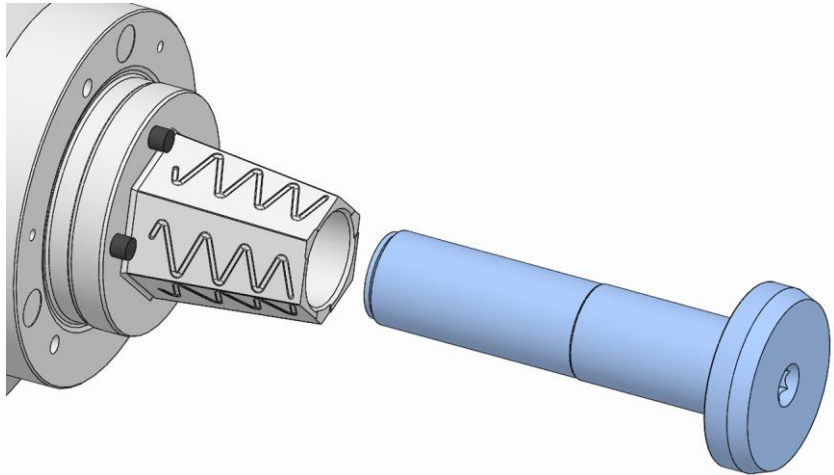

WARNING

Serious injuries caused by tension bolt being ejected centrifugally if tightening torque is incorrect!

- Always tighten the tension bolt down into the product and tighten to the specified tightening torque [see nomenclature].

19. Screw the tension bolt into the product and tighten to the specified tightening torque [see nomenclature].

7.5.8 Installation of the functional unit of a non-alignable clamping device

1. Attach any lifting gear that may be required.
2. If necessary, fit the mounting aid onto a vertically suspended spindle.
3. Move the machine drawtube to the front limit stop.

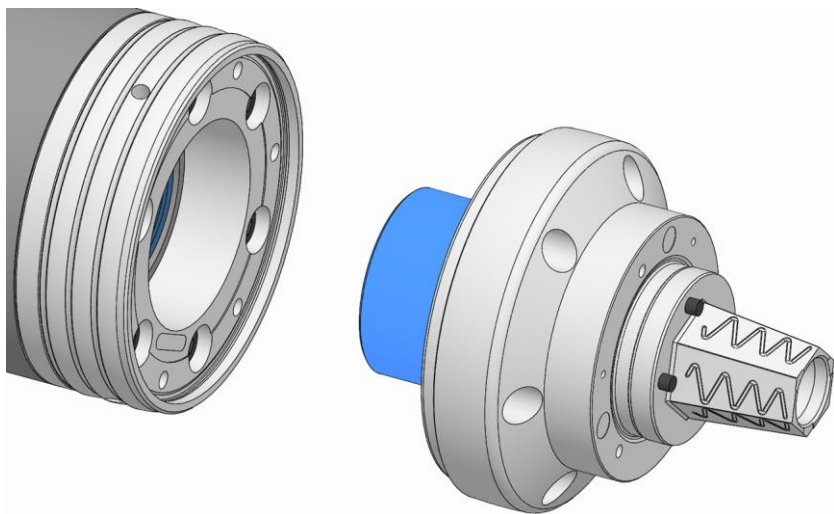



NOTE

Damage to materials caused by incorrect installation when using the adapter to check the air system!

- Ensure that the sealing elements do not fall out or get damaged during installation, and apply a thin coat of grease if necessary.



INFORMATION

If lifting gear needs to be used, rotate the spindle flange and machine spindle manually to tighten / un-tighten the functional unit.

4. Screw the functional unit firmly home on the machine drawtube.

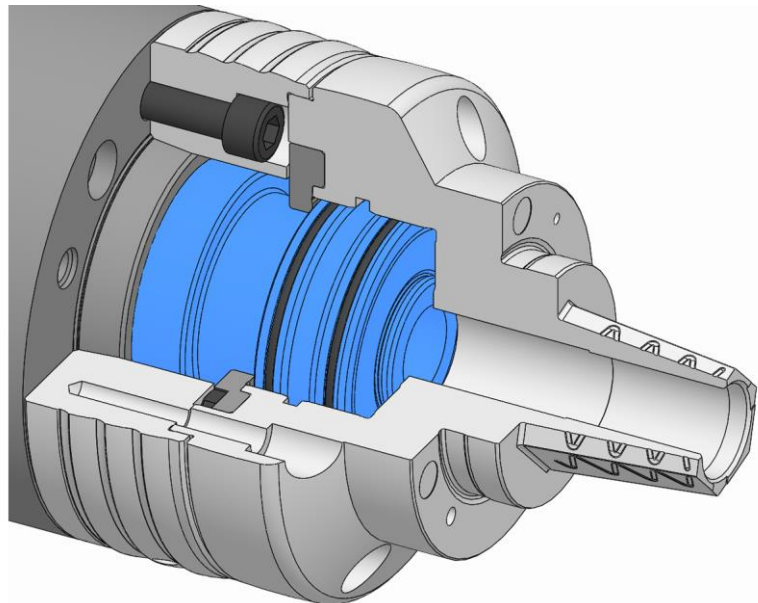

5. Turn back the functional unit until the hole patterns on the spindle flange and functional unit are aligned.



WARNING

Serious crushing injuries caused by improper machine movement during installation!

- Never reach into the gap between machine tool, spindle flange and functional unit.

6. Using the least possible force and speed, move the drawtube on the machine to its front limit stop [see »Preparing the machine for installation« chapter].

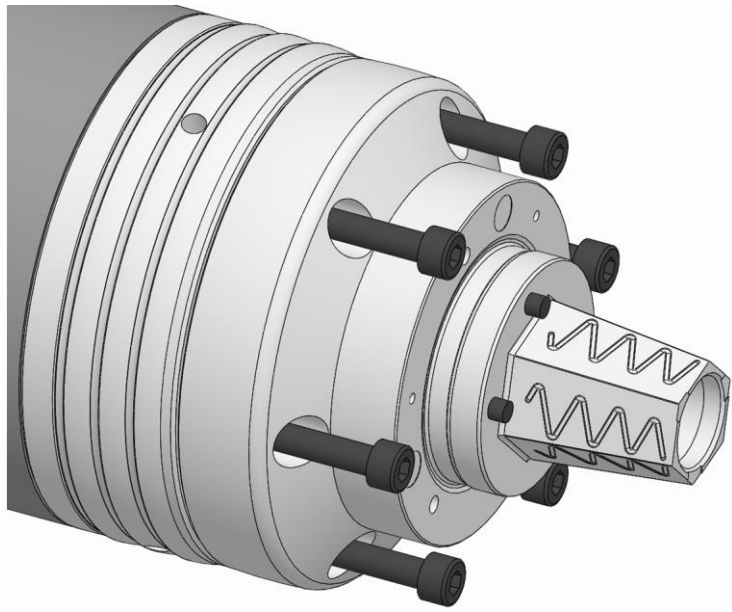

7. Screw in the fixing screws on the functional unit and tighten to the specified tightening torque [see »Screw tightening torques« chapter].
8. Unfasten and remove any lifting gear that may have been required.
9. Remove the mounting aid on a vertically suspended spindle if one was used.
10. Check face run-out on the test surface of the functional unit [ideally ≤ 0.01 mm].
11. Check axial run-out on the test surface of the functional unit [ideally ≤ 0.003 mm].

Whenever the face run-out and/or the axial run-out is greater than the maximum permitted value:

12. Remove the functional unit.
13. Clean the locating face and the mating faces of the spindle flange and the functional unit.
14. If there is a burr or slight damage, rub down the locating face of the spindle flange or the functional unit gently with an oil stone.
15. Reinstall the functional unit.
16. Repeat the face run-out test.
17. Repeat the axial run-out test.

If a clamping element is to be installed, proceed with installation of the clamping element [see »Installation of the clamping element« chapter].

If no clamping element is to be installed, the following steps are required.

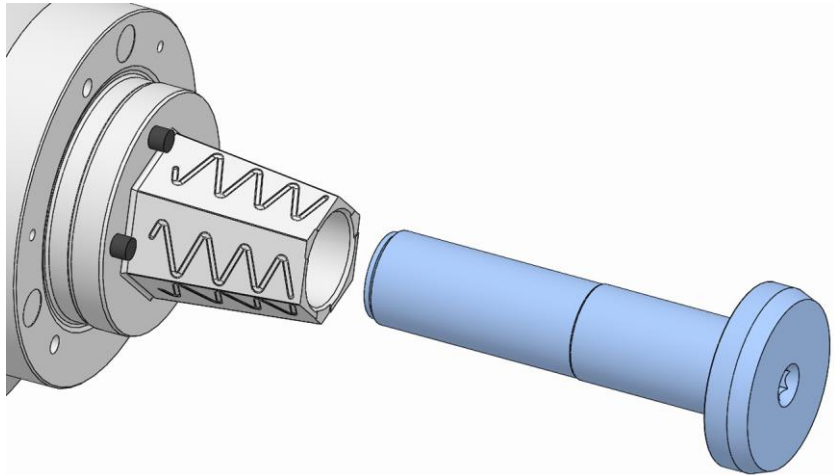

WARNING

Serious injuries caused by tension bolt being ejected centrifugally if tightening torque is incorrect!

- Always tighten the tension bolt down into the product and tighten to the specified tightening torque [see nomenclature].

18. Screw the tension bolt into the product and tighten to the specified tightening torque [see nomenclature].

7.6 Installation of the clamping element

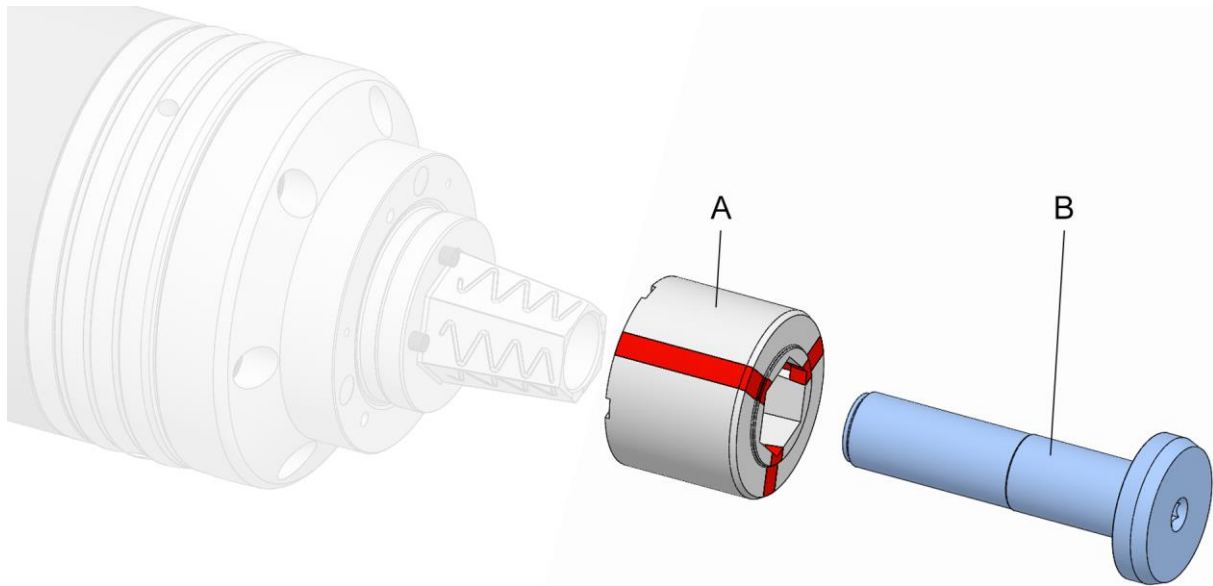

- A Segment clamping bushing [clamping element]
- B Tension bolt



INFORMATION

Before installing the clamping element, install the changing part if necessary, otherwise it can no longer be installed.

1. As described in the »Preparation of the machine for installation« chapter, prepare for the following steps.



INFORMATION

To install the clamping element, the tension bolt must be removed [see »Preparation of the product« chapter].

2. Move the clamping device into release position.

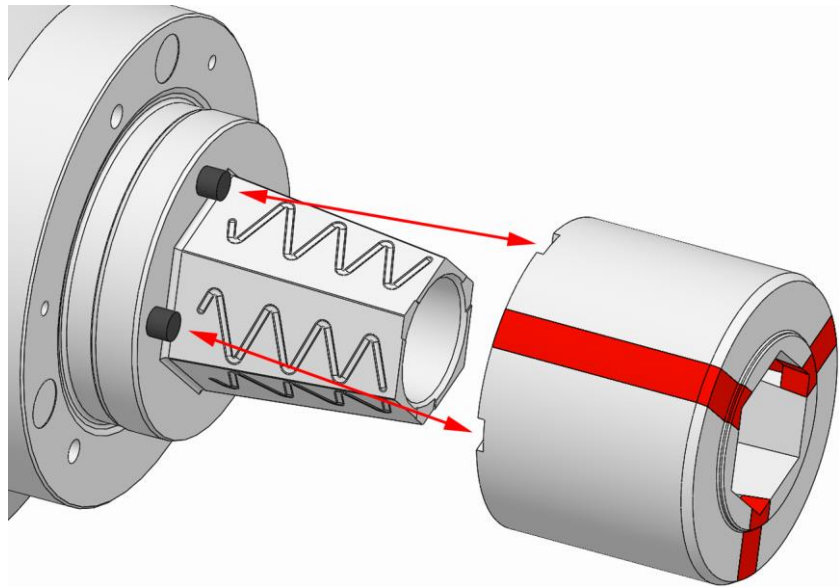

3. Fit the segmented clamping bushing to the product. For this, the grooves in the segmented clamping bushing must engage in the ejector pins.

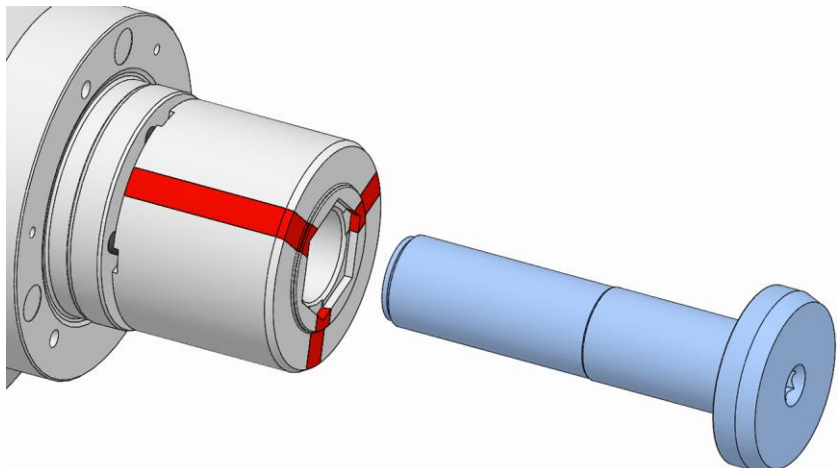

WARNING

Serious injuries caused by tension bolt being ejected centrifugally if tightening torque is incorrect!

- Always tighten the tension bolt down into the product and tighten to the specified tightening torque [see nomenclature].

4. Screw the tension bolt into the product and tighten to the specified tightening torque [see nomenclature].

7.7 Installation of the changing parts

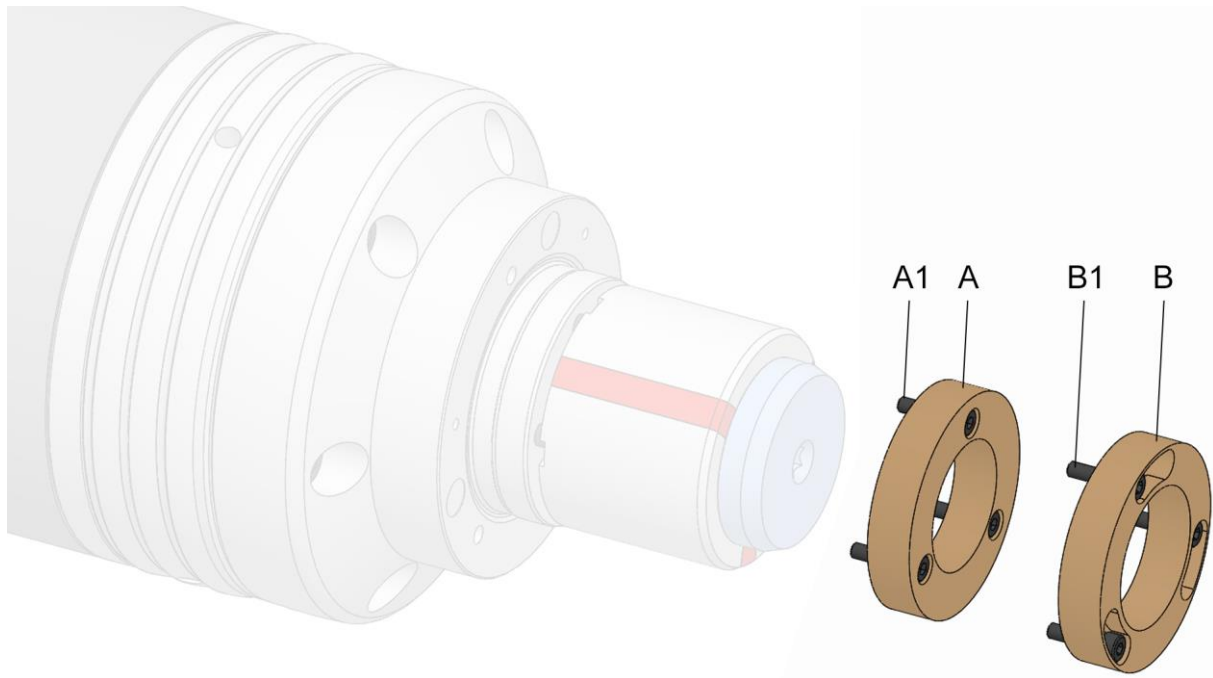

- A Changing part variant x-times axial screwed connection
- A1 Fixing screws, changing part variant x-times axial screw connection
- B Changing part variant x-times axial screw connection bayonet
- B1 Fixing screws changing part variant x-times axial screw connection bayonet

The changing parts, such as the workpiece end-stop, can be installed in different ways.



If necessary, in addition to these operating instructions, you should also read and follow the operating instructions for the relevant changing parts.



INFORMATION

To be able to install the changing part, it may first be necessary to remove the clamping element.

1. As described in the »Preparation of the machine for installation« chapter, prepare for the following steps.
2. Move the clamping device into release position.



INFORMATION

If necessary, the changing part is positioned. Positioning can for example be performed by marks, or a cylindrical pin and a bore or a groove.

7.7.1 Installation of the variant x-times with axial screw connection

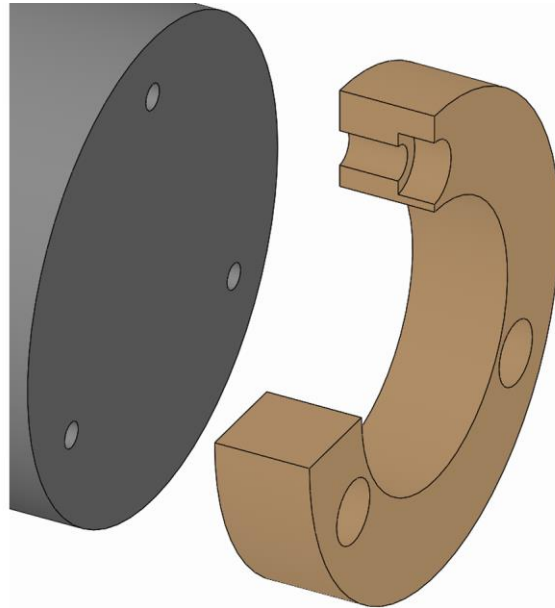

1. Place the changing part onto the product.

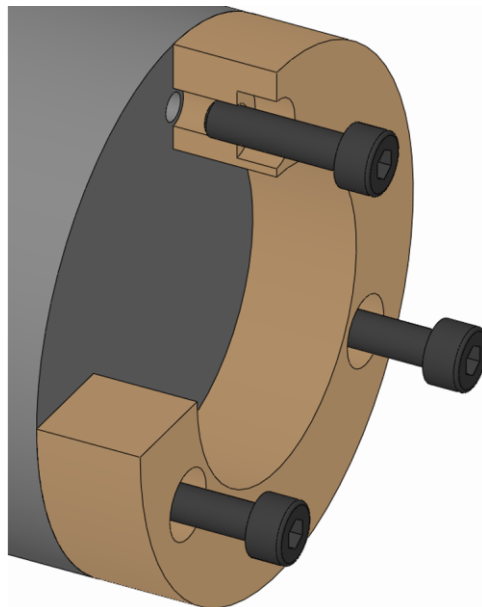

2. Screw in the changing part fixing screws on the changing part and tighten to the specified tightening torque [see »Screw tightening torques« chapter].

7.7.2 Installation of the variant x-times with bayonet axial screw connection



INFORMATION

Initial installation of the changing part with bayonet is in accordance with the variant with an x-times axial screw connection, see »Installation of x-times variant with axial screw connection«.

After initial installation, the changing part fixing screws remain in the clamping device.

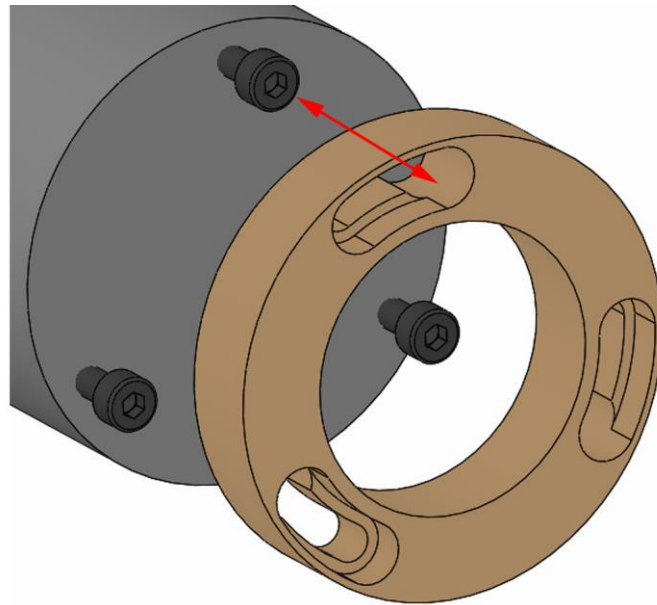

1. Place the changing part on the product so that the screw head on the changing part fixing screw fits through the bayonet opening.

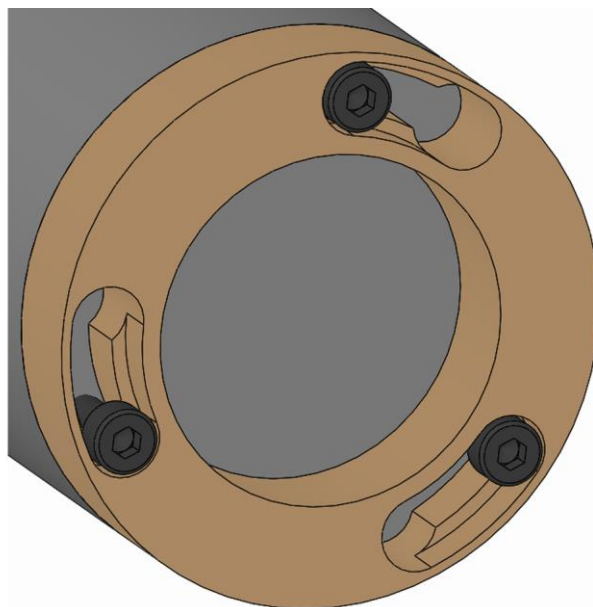

2. Twist the changing part until firmly home.

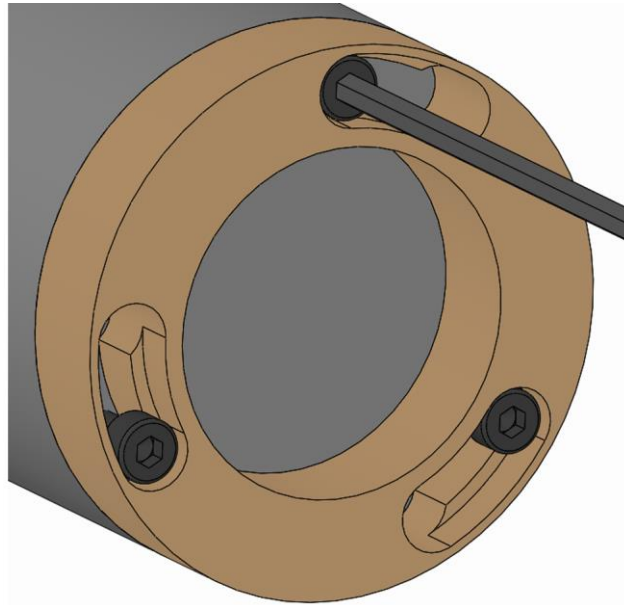

3. Screw in the changing part fixing screws and tighten to the specified tightening torque [see »Screw tightening torques« chapter].

7.8 Aligning the clamping device with the test specimen

To achieve the greatest possible accuracy, the clamping device must be aligned on the workpiece. For this, a test specimen can be used. A test specimen can take the form of a test ring, a test shaft or a test workpiece [this is approximated on the workpiece contour].

To align the clamping device using the test specimen, the functional unit fixing screws must be readily accessible.

1. As described in the »Preparation of the machine for installation« chapter, prepare for the following steps.
2. Install the appropriate clamping element for the test specimen and changing part [see »Installation of clamping element« and »Installation of changing parts« chapters].
3. Clamp the test specimen.
4. Unfasten the fixing screws on the functional unit a few turns without removing them.
5. Align the clamping device [see alignment process from the »Installation of functional unit of an alignable clamping device« chapter].
6. Ensure that the fixing screws on the functional unit are tightened back down after the alignment process to the specified tightening torque [see »Screw tightening torques« chapter].

8 Commissioning

For commissioning purposes, set the operating pressure to the permitted, established machining value.

The machine tool must not start up until full operating pressure has built up.

8.1 Commissioning safety



DANGER

Serious injuries caused by workpieces being ejected centrifugally or dropping out if clamping force is insufficient!

- Workpiece blanks must not be outside the clamping width diameter.
- Prior to commissioning, set the actuation force to the permitted, established machining value.
- Clamping of the workpiece must not be outside the defined limits [see »Limits of use« chapter].
- Check the clamping force at regular intervals and correct if necessary.



WARNING

Serious injuries can be caused if the machine tool starts up accidentally!

- Prior to commissioning, close all safety doors or hoods on the machine tool.



WARNING

Serious injuries caused by tools and items of test equipment being ejected centrifugally!

- Prior to commissioning, ensure that all tools and items of test equipment are removed from the working area of the machine.



NOTE

Serious damage to materials / the product caused by workpieces being ejected centrifugally or dropping out if clamping force is insufficient!

- Workpiece blanks must not be outside the clamping width diameter.
- Prior to commissioning, set the actuation force to the permitted, established machining value.
- Clamping of the workpiece must not be outside the defined limits [see »Limits of use« chapter].
- Check the clamping force at regular intervals and correct if necessary.



NOTE

Damage to components caused by cooling lubricants with sufficient levels of corrosion inhibitor!

- The components made of steel materials must be protected before the usual oxidation process.
- Only ever use cooling lubricants with sufficient levels of corrosion inhibitor.



NOTE

Damage to materials caused by contaminated / unprocessed cooling lubricants!

- For the product to function properly, in particular for internal flushing with cooling lubricants and/or when using tools with internal flushing, ensure that the cooling lubricant is cleaned / processed, and that it contains no particles measuring >100 microns [filtered with a mesh width of 100 microns].



NOTE

Damage to seals caused by using the wrong coolant lubricants!

- To clean the product, never use a cooling lubricant that attacks and damages the sealing elements installed. Those installed sealing elements can be made of NBR, Viton and PUR materials.
- Never use cooling lubricants that contain ester or a polar solvent.



NOTE

Damage to clamping elements caused by using the wrong cooling lubricants!

- Never use cooling lubricants that contain ester or a polar solvent.

8.2 Checking the total stroke



WARNING

Serious crushing injuries caused by moving parts when stroke positions are being tested!

- Set the machine into set-up mode.
- Reduce the operating pressure to a minimum.
- Never reach into moving parts.
- Pay attention to the gap dimensions of moving parts.

Prior to commissioning, check the complete stroke to ensure that there is sufficient reserve stroke and opening stroke.

For this, the same measurement of the moving part must be performed at fixed points in front and rear limit positions.

Then deduct the value obtained in the rear limit position from the value obtained from the front limit position. This figure must then be equal to or greater than the nominal total stroke.

For the axial nominal total stroke, the values of axial clamping reserve and axial release stroke must be added together [see »General information« chapter].

8.3 Tests



NOTE

Serious damage to, or destruction of, the machine tool and the workpiece caused by damaged, incomplete or incorrectly installed products!

- Only install undamaged and complete products properly.
- If in doubt, contact the manufacturer.

Assure the following points before every installation and/or before every time the products are put into service:

- The products used are undamaged.
- All fixing screws are present on the products, and are tightened to the correct tightening torque.
- None of the rubber segments on the clamping elements and attachments are torn or exhibit porous areas.
- Serrations and grooved profiles must not be excessively rounded because this would prevent the friction coefficient from being achieved.
- None of the edges and races are chipped or show any signs of wear.
- The speed set on the machine tool must not exceed the maximum speed of the product. Always take the lowest value of all maximum speeds for combined products indicated.

- Pay attention to the level of actuating force established to enable the workpiece to be clamped with sufficient clamping force.
- Do not exceed the maximum actuating force indicated on the product. Always take the lowest value of all actuating forces indicated for combined products.
- All installation tools are removed from the machining area.
- Clamping device and workpiece are compatible - check clamping diameter on a regular basis.
- Conduct a clamping force measurement.

8.4 Workpiece



DANGER

Serious injuries caused by parts being ejected centrifugally if level of workpiece clamping is insufficient!

- Never utilize the full clamping reserve.
- Do not exceed the permitted maximum clamping reserve stroke.
- The remaining clamping reserve must always be adapted to suit the workpiece material provided and its possible distortions.



WARNING

Crushing injuries to hands / fingers is workpiece is installed incorrectly!

- Do not place hands / fingers between workpiece and clamping device.
- Never reach into the clamping area.



CAUTION

Burns caused by high workpiece temperature!

- Give preference to automatic loading.
- Also wear the following items of personal protective equipment, in addition to the basic equipment:



8.5 Procedure after a collision

In the event of a collision, the product and its components must be checked for cracks and damage before being used again.

For this, remove the product from the machine [see »Removal of the product« chapter] and dismantle it [for level of disassembly, see »Cleaning« chapter].

9 Activities after end of production

1. Move product into release position.
2. Switch off machine tool and secure it to prevent it from being switched back on.
3. Open the safety door / hood.



WARNING

Eye injuries and cuts caused by failure to wear protective clothing during cleaning operation!

- Never use compressed air to clean the product.
- Also wear the following items of personal protective equipment, in addition to the basic equipment:



4. Clean the product of swarf and production residue with a soft, lint-free cloth and apply a light coating of oil.
5. Close the safety door / hood.

10 Removal

If a break in production occurs that lasts for more than three days, the product must be removed and stored safely in accordance with the manufacturer's stipulations [see »Transport, packaging, storage« chapter].

10.1 Safe removal



WARNING

Serious injuries caused by unskilled staff during installation / removal!

- Installation and removal must be performed by skilled staff from the relevant specialist field.



WARNING

Serious injuries can be caused if the machine tool starts up accidentally!

- Set the machine tool into set-up mode.
- Remove all tools, auxiliary equipment and items of test equipment immediately from the working area of the machine.
- Remove all lifting gear from the product and from the working area of the machine.



WARNING

Serious injuries caused by the escape of media under high pressure!

- Shut down media delivery during installation and removal.
- Relieve any pressure trapped in the system.
- Shut down the system.



WARNING

Serious crushing injuries and breakages caused by falling parts during incorrect installation or removal!

- Ensure that the product cannot roll away or fall.
- If necessary, use an appropriate mounting aid for installation or removal on a vertically suspended machine spindle.



WARNING

Serious crushing injuries caused by improper machine movement during installation or removal!

- Machine movements are only permitted in set-up mode during installation and removal.
- Never reach into a gap.
- Pay attention to the gap dimensions of moving parts.



WARNING

Serious head injuries caused by bending into the working area of the machine!

- Only ever bend into the working area of the machine if there are no cutting tools or sharp objects in it, or if these are covered.
- Never move body parts under parts in the working area of the machine with the potential to drop down.
- Depending on weight, use an appropriate mounting aid for installation or installing on a vertically suspended machine spindle.



WARNING

High level of physical strain due to the weight of the product or of its components if not transported properly!

- From a weight of 10 kg, use appropriate transport equipment, lifting gear and lifting tackle.



CAUTION

Serious cut injuries caused by sharp-edged changing parts and/or clamping elements!

- All installation / removal of changing parts and clamping elements must be performed by skilled staff from the relevant specialist field.



INFORMATION

If necessary, use any forcing / extraction threads in the components of the product, changing parts or clamping elements.

10.2 Preparing the machine for removal

1. Set the machine into set-up mode.



INFORMATION

The minimum operating pressure is reached when the drawtube can still just be moved without triggering an error message.

2. Reduce the operating pressure to a minimum.
3. Remove cutting tools and/or sharp objects from the working area of the machine, or cover them.
4. Remove operating and auxiliary materials as well as remaining processing materials and dispose of them in an environmentally responsible manner.

10.3 Removal of the changing parts

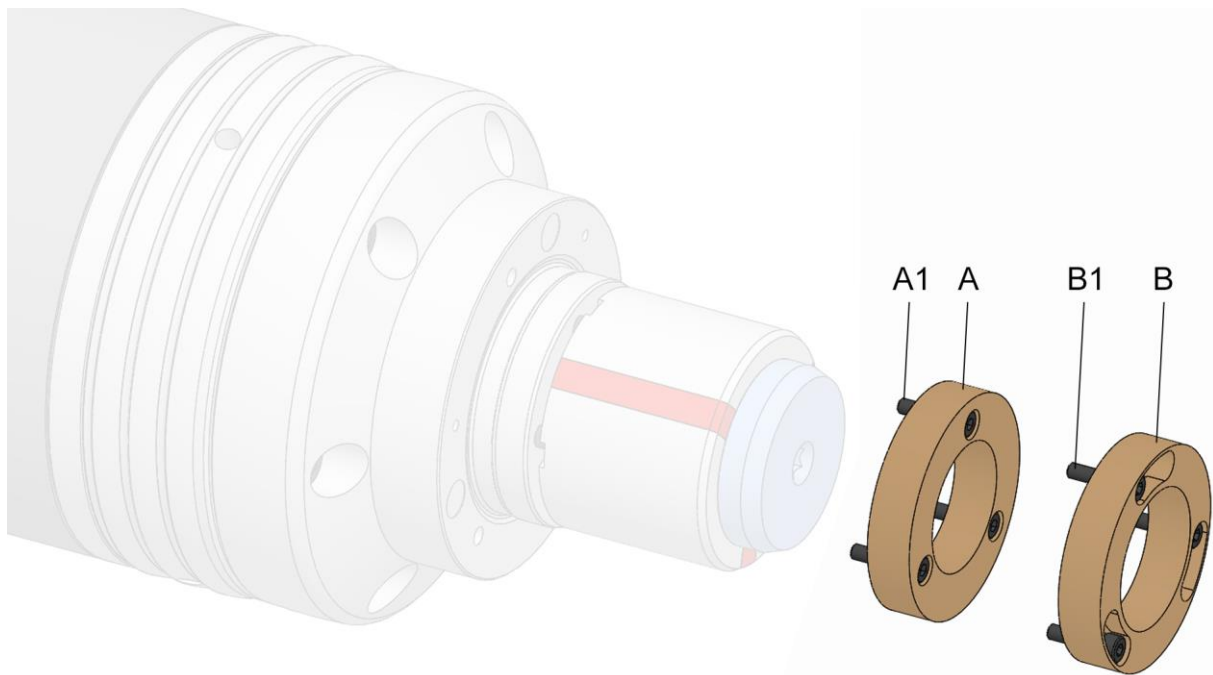

- A Changing part variant x-times axial screwed connection
- A1 Fixing screws, changing part variant x-times axial screw connection
- B Changing part variant x-times axial screw connection bayonet
- B1 Fixing screws changing part variant x-times axial screw connection bayonet

Depending on the version of changing parts, they can be removed as follows.



If necessary, in addition to these operating instructions, you should also read and follow the operating instructions for the relevant changing parts.



INFORMATION

To be able to remove the changing part, it may be necessary to remove the clamping element first.

1. As described in the »Preparing the machine for removal« chapter, prepare for the following steps.
2. Move the clamping device into release position.

10.3.1 Removal of the variant x-times with axial screw connection

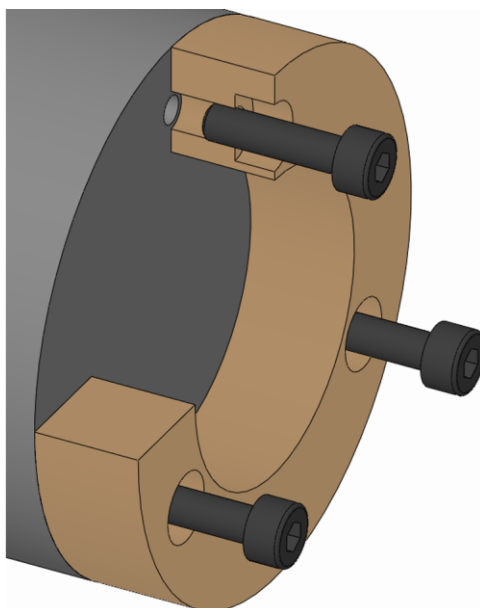

1. Unfasten and remove the fixing screws on the changing part.

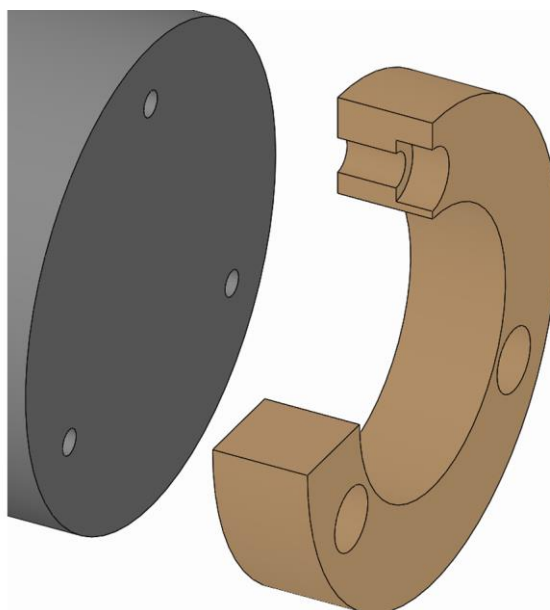

2. Take the changing part off the product.

10.3.2 Removal of the variant x-times with axial screw connection bayonet

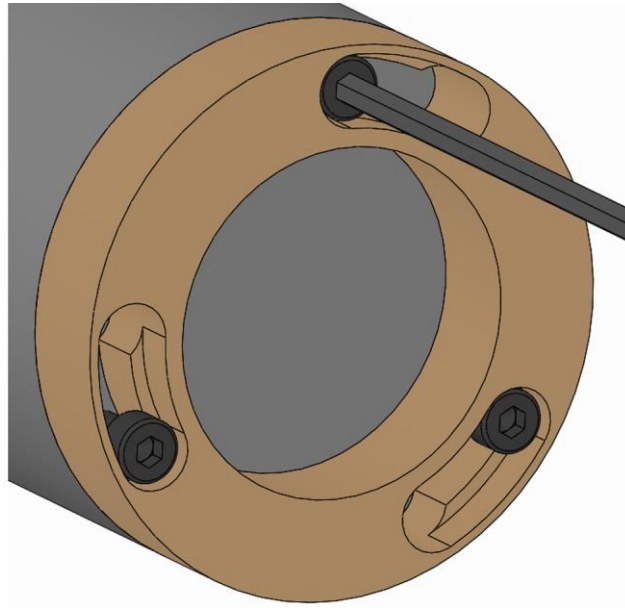

1. Unfasten the fixing screws on the changing body a few turns without removing them.

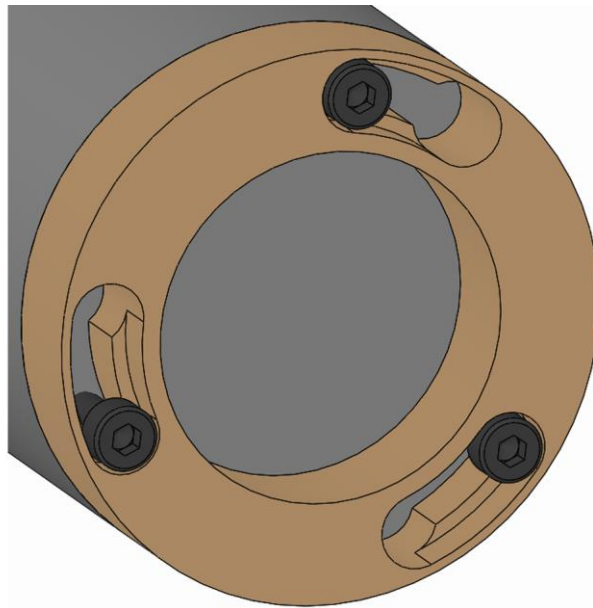

2. Turn the changing part until the screw head on the changing part fixing screw fits through the bayonet opening.

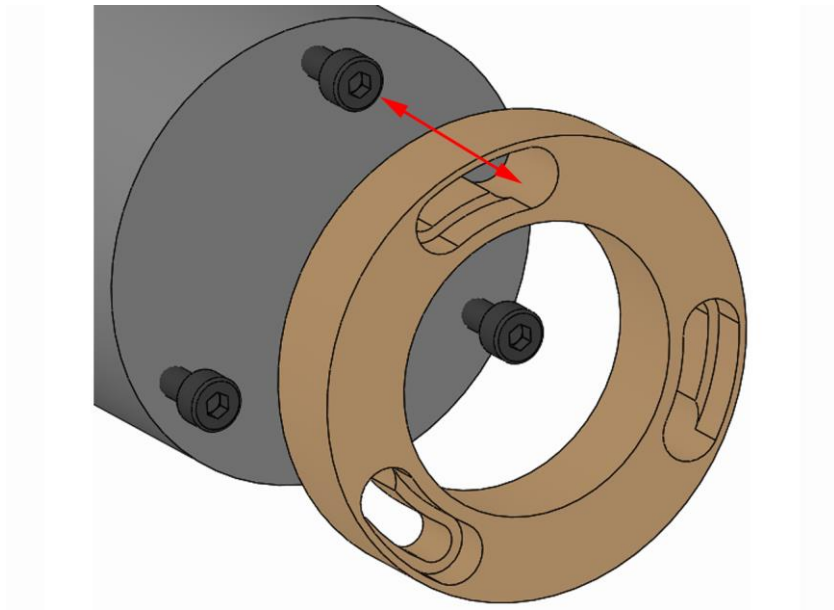

3. Take the changing part off the product.

10.4 Removal of the clamping element

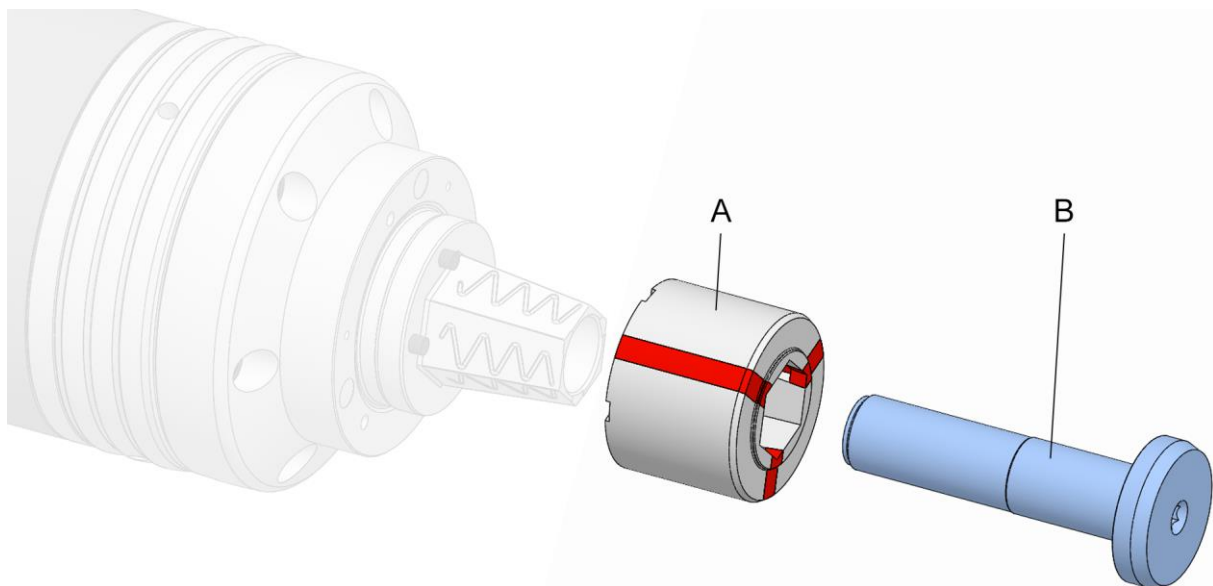

- A Segment clamping bushing [clamping element]
- B Tension bolt

1. As described in the »Preparing the machine for removal« chapter, prepare for the following steps.
2. Move the clamping device into release position.

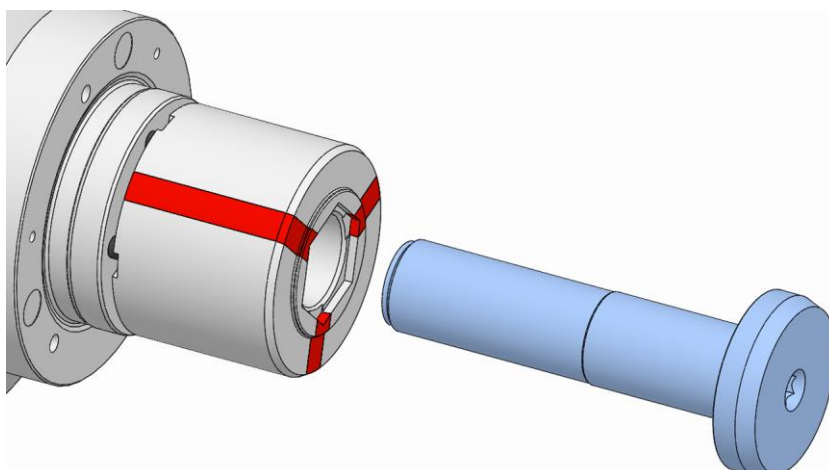

3. Unfasten and remove the tension bolt.

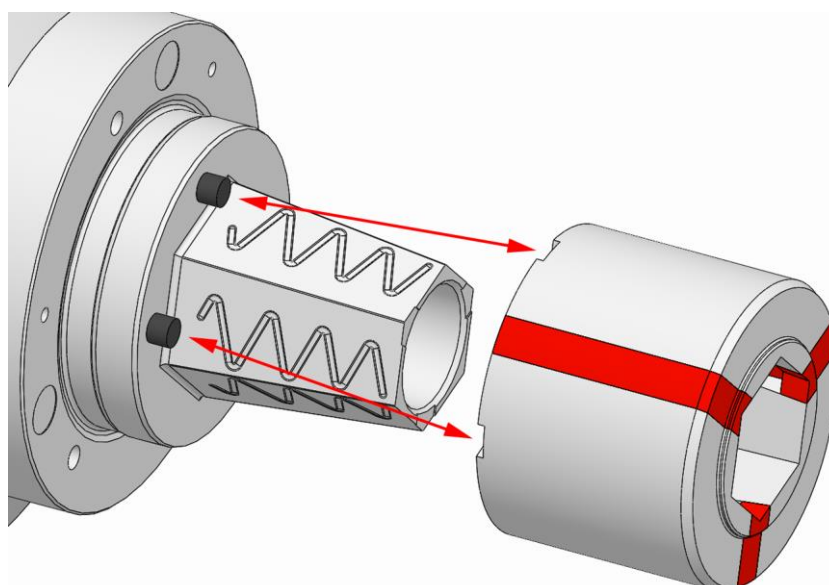

4. Take the segmented clamping bushing off the product.
If a different clamping element is to be installed, proceed with installation of the clamping element [see »Installation of the clamping element« chapter].
If the product is to be removed, proceed with removal of the product [see »Removal of the product« chapter].
If no clamping element is to be installed, and if the product is to remain on the machine, the following steps are required.

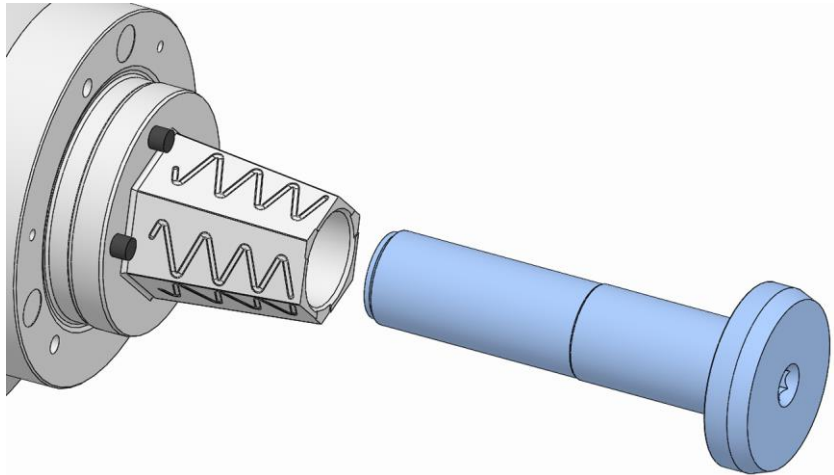

WARNING

Serious injuries caused by tension bolt being ejected centrifugally if tightening torque is incorrect!

- Always tighten the tension bolt down into the product and tighten to the specified tightening torque [see nomenclature].

5. Screw the tension bolt into the product and tighten to the specified tightening torque [see nomenclature].

10.5 Removal of the product

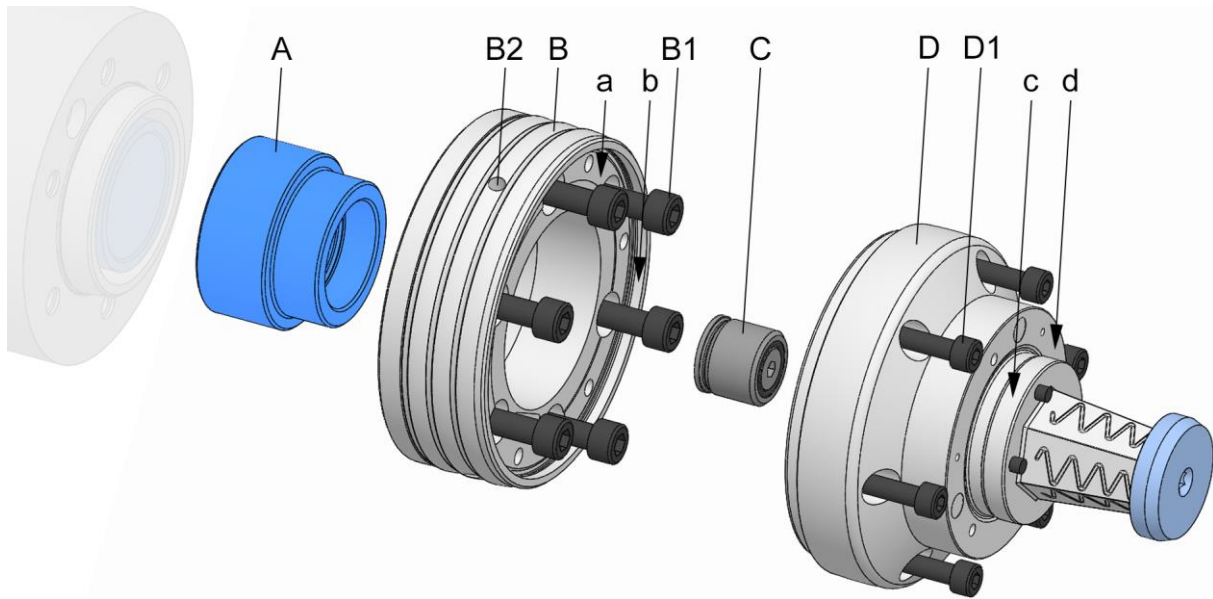

- A Drawtube adapter
- B Spindle flange
- B1 Fixing screws, spindle flange
- B2 Transport thread spindle flange
- C Adapter for checking air system
- D Functional unit
- D1 Fixing screws on functional unit
- a Test surface face run-out spindle flange
- b Test surface axial run-out spindle flange
- c Test surface axial run-out functional unit
- d Test surface face run-out functional unit

1. As described in the »Preparing the machine for removal« chapter, prepare for the following steps.

10.5.1 Removal of the product from an actuating unit



INFORMATION

To remove the product, the tension bolt must be removed [see »Removal of the clamping element« chapter].



INFORMATION

Installation / removal of the product is described in the operating instructions for the actuating unit.



In addition to these operating instructions, you should also read and follow the operating instructions for the actuating unit.

1. Remove the product.

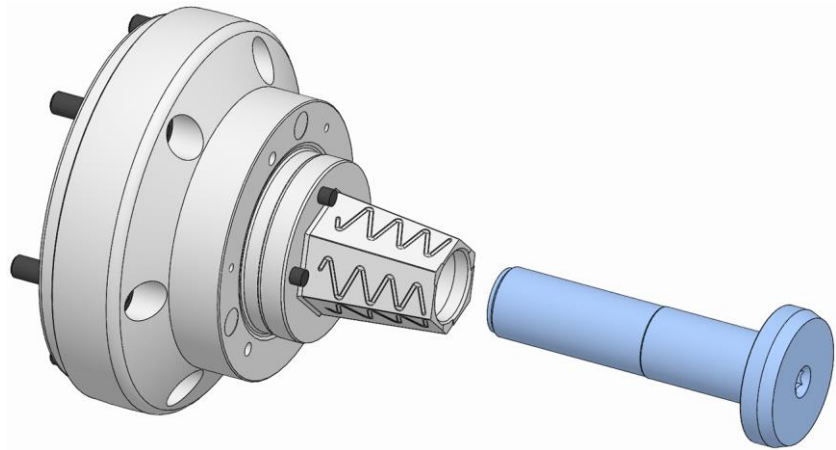

WARNING

Serious injuries caused by tension bolt being ejected centrifugally if tightening torque is incorrect!

- Always tighten the tension bolt down into the product and tighten to the specified tightening torque [see nomenclature].

2. Screw the tension bolt into the product and tighten to the specified tightening torque [see nomenclature].

10.5.2 Removal of the functional unit



INFORMATION

To remove the product, the tension bolt must be removed [see »Removal of the clamping element« chapter].

1. Attach any lifting gear that may be required.
2. If necessary, fit the mounting aid onto a vertically suspended spindle.
3. Move the machine drawtube to its rear limit stop.

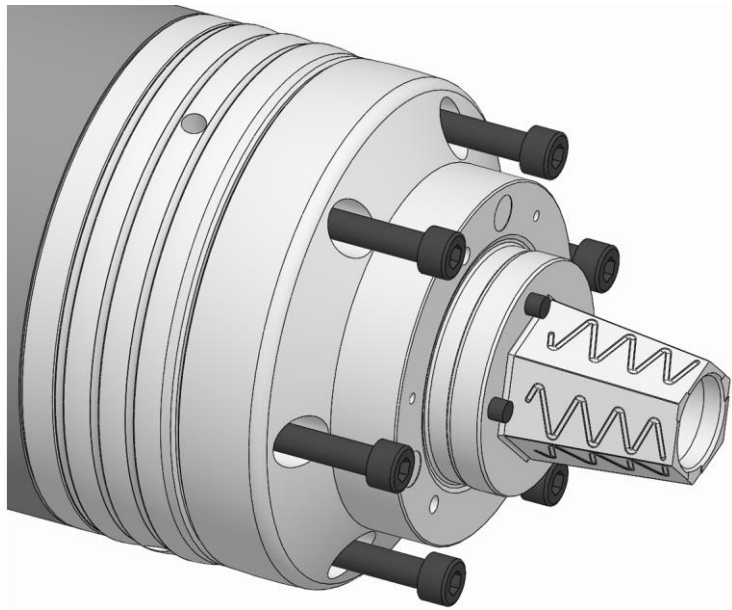

4. Unfasten and remove the fixing screws on the functional unit.
5. Using the least possible force and speed, move the drawtube on the machine to its front limit stop [see »Preparing the machine for removal« chapter].

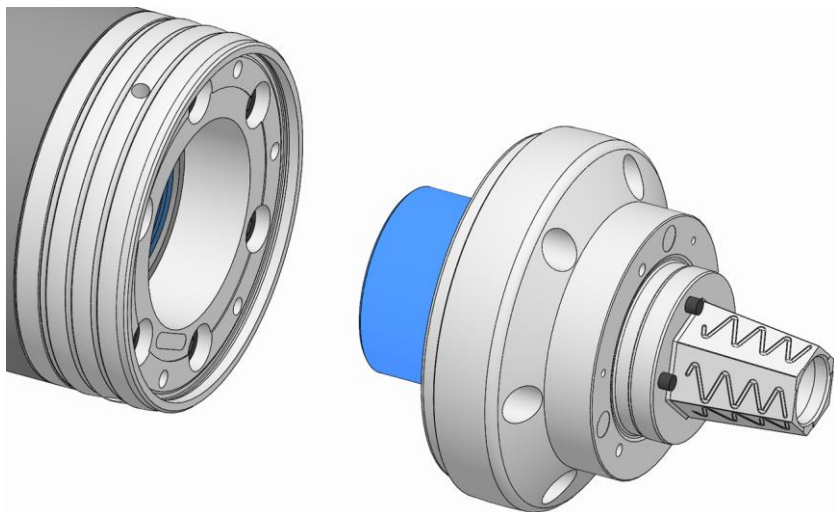

INFORMATION

If lifting gear needs to be used, rotate the spindle flange and machine spindle manually to tighten / un-tighten the functional unit.

6. If necessary, unscrew and remove the functional unit from the machine drawtube.

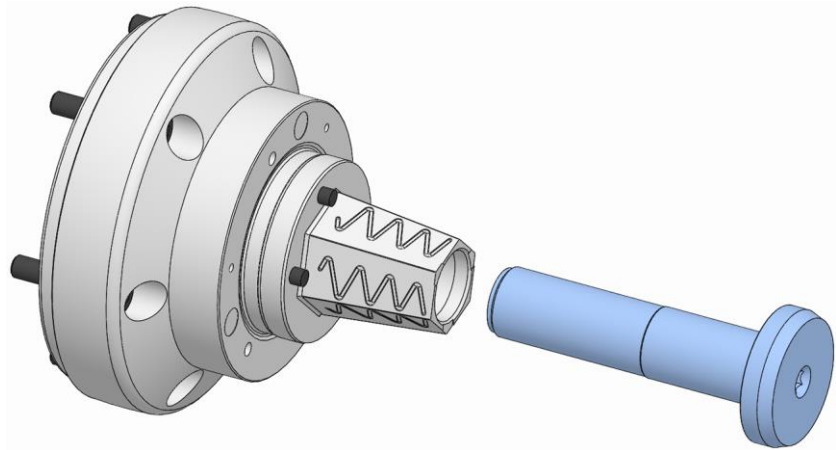

WARNING

Serious injuries caused by tension bolt being ejected centrifugally if tightening torque is incorrect!

- Always tighten the tension bolt down into the product and tighten to the specified tightening torque [see nomenclature].

7. Screw the tension bolt into the product and tighten to the specified tightening torque [see nomenclature].

10.5.3 Removal of the spindle flange

1. Attach any lifting gear that may be required.
2. If necessary, fit the mounting aid onto a vertically suspended spindle.

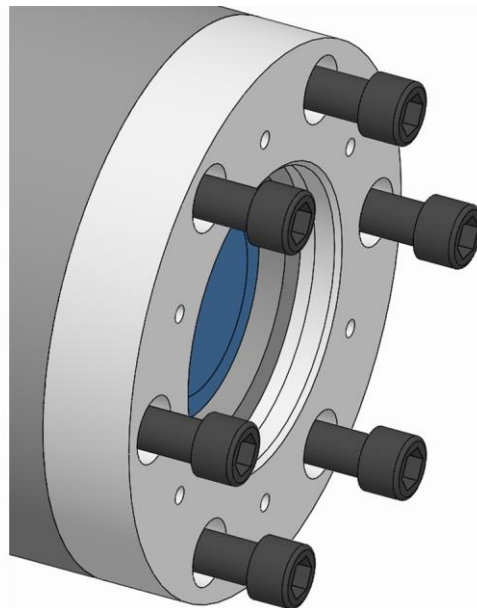

3. Unfasten and remove the fixing screws on the spindle flange.

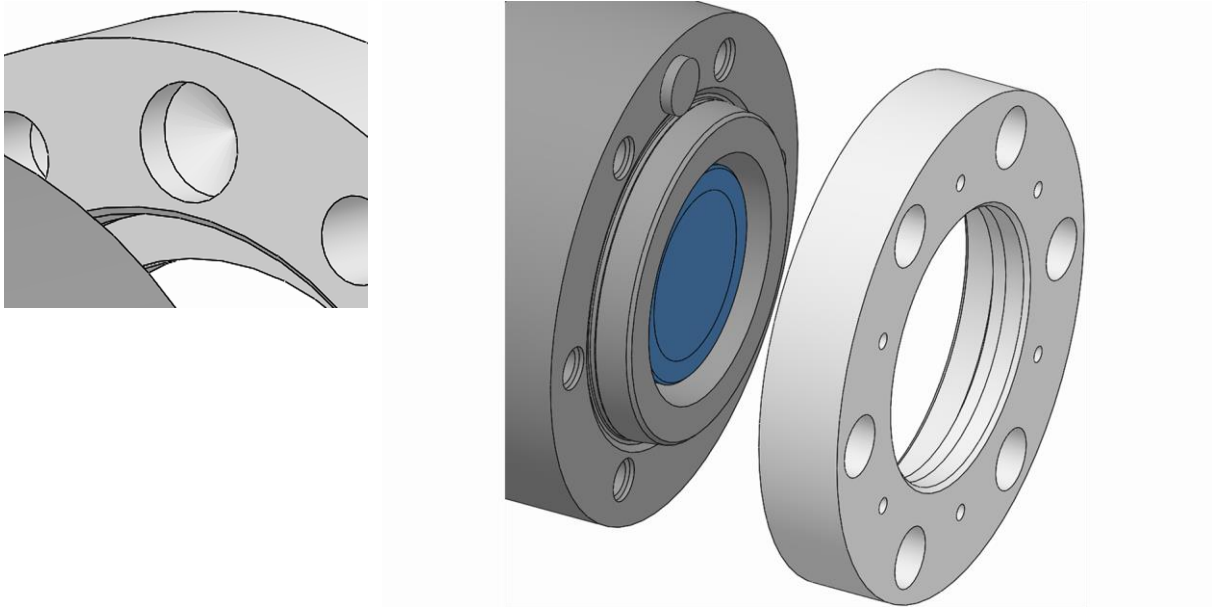

4. Take down the spindle flange from the machine spindle.

10.5.4 Removal of the drawtube adapter

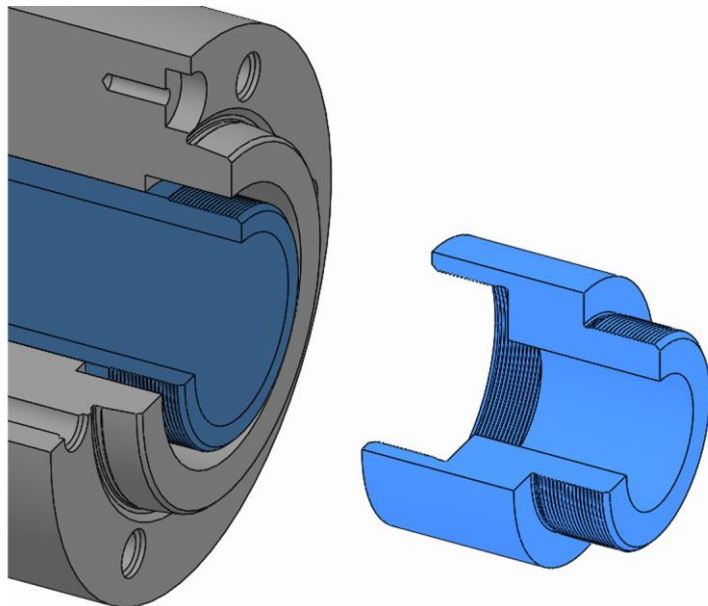

1. If the drawtube adapter was mounted on the machine drawtube, use its thread to unscrew and remove it from the machine drawtube.

11 Maintenance

11.1 Maintenance safety



WARNING

Serious injuries caused by parts being ejected centrifugally after a loss of clamping power!

- Maintain the maintenance and cleaning intervals of the product at all times.
- It is essential to check the maintenance status of the product at regular intervals with a structural clamping force measurement.



CAUTION

Health risks caused by incorrect handling of cleaning agents!

- Pay attention to hazard specifications and the safety data sheet of the manufacturer.



INFORMATION

If necessary, use any forcing / extraction threads in the components of the product, changing parts or clamping elements.

11.2 Maintenance schedule

The following sections describe the maintenance work needed to ensure optimum and fault-free operation.

If increased levels of wear are detected during regular checks, shorten the maintenance intervals to reflect the actual rate at which signs of wear appear.

Contact the manufacturer for questions relating to maintenance work and maintenance intervals [see »Contact« chapter].

Interval	Maintenance work
daily	Visual inspection of clamping and mating surfaces for signs of wear, nicks and cracks [see »Visual inspection« chapter]
	Visual inspection of rubber on clamping element for signs of wear, nicks and cracks [see »Visual inspection« chapter]
	Complete cleaning if heavily soiled [see »Cleaning« chapter]
	Conduct a structural clamping force measurement
weekly or after 40- operating hours*	Remove the clamping element [see »Removal of the clamping element« chapter]
	Clean the clamping element, clamping taper and coupling area [see »Cleaning« chapter]
six-monthly or after 1500 operating hours*	Completely clean the product [see »Cleaning« chapter]
	Lubricate the product [see »Lubricating the product« chapter]
with storage	See »Storage« chapter

* depending upon which stipulation is achieved first
Table 7: Maintenance table

11.3 Cleaning

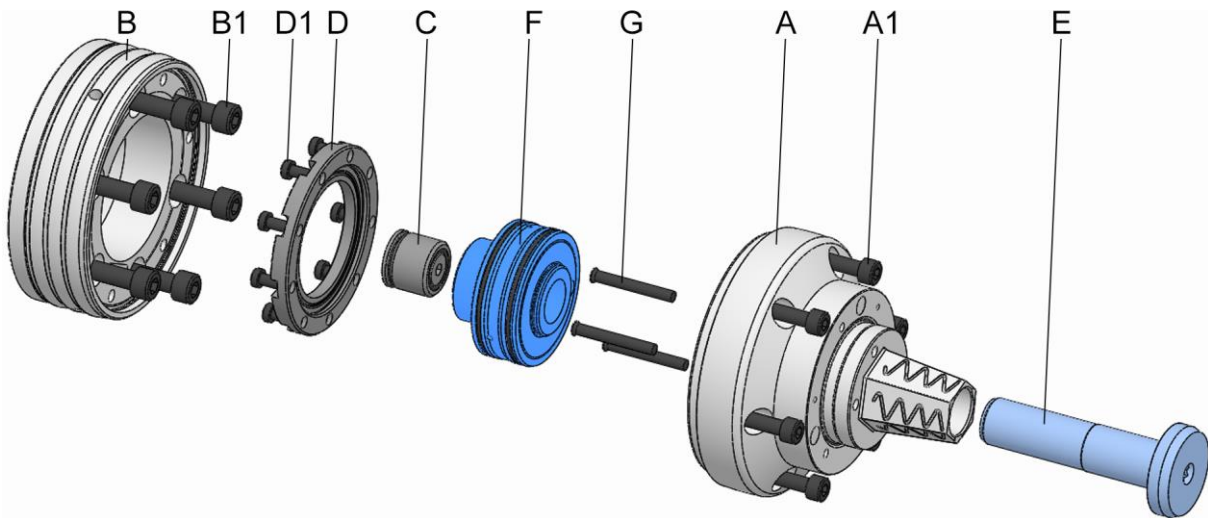

- A Drift body
- A1 Fixing screws drift body
- B Spindle flange
- B1 Fixing screws, spindle flange
- C Adapter for checking the air system
- D Ring
- D1 Ring fixing screws
- E Tension bolt
- F Adapter
- G Ejector pins



WARNING

Eye injuries and cuts caused by failure to wear protective clothing during cleaning operation!

- Never use compressed air to clean the product.
- Also wear the following items of personal protective equipment, in addition to the basic equipment:



NOTE

Damage to seals caused by the wrong solvent!

- To clean the product, never use a solvent that attacks and damages the sealing elements installed. Those installed sealing elements can be made of NBR, Viton and PUR materials.
- To clean the product, never use a solvent that contains ester, nor a polar solvent.



NOTE

Damage to clamping elements caused by the wrong solvent!

- To clean the product, never use a solvent that contains ester, nor a polar solvent.



NOTE

Damage to materials caused by incorrect installation of sealing elements!

- Replace missing or damaged sealing elements.
- Ensure that the sealing elements do not fall out or get damaged during installation / removal, and apply a thin coat of grease if necessary.

Cleanliness of the relevant limit stop and guide diameter are essential for achieving axial and face run-out tolerances.

1. Remove the changing parts and the clamping element from the product [see »Removal of changing parts« and »Removal of clamping element« chapters].
2. Remove the product from the machine [see »Removal of the product« chapter].



WARNING

Serious injuries caused by imbalance resulting from incorrect reassembly!

- The product components must be installed back in the same position.
- If necessary, mark out the relative positions of components prior to disassembly.



NOTE

Damage to materials caused by incorrect Removal of the product!

- More extensive disassembly than shown on the exploded drawing is prohibited.



INFORMATION

During removal of the product, take care not to lose any components.

3. Dismantle the product as shown on the exploded drawing.
4. Clean all oil and grease residues off all components with an ester-free, non-polar, soft, lint-free cloth and check for visible signs of damage.
5. Assemble the product in accordance with the exploded drawing and lubricate during assembly [see »Lubricating

the product« chapter]. Pay attention to the following during assembly:

- Replace worn or damaged fixing screws.
- Tighten all fixing screws to the specified tightening torque [see nomenclature and/or »Screw tightening torques« chapter]. When tightening the screws, do so evenly to prevent any distortion under load.
- Only apply lubricant to the mechanical mating surfaces. Pay attention to notes about lubricants [see »Use of lubricants« chapter].
- Avoid too much lubricant on the locating face because this can cause face run-out errors.
- Apply grease to the sealing elements [for example O-rings, rectangular rings] and sealing surfaces. Pay attention to notes about greases [see »Use of lubricants« chapter].

11.4 Visual inspection

Perform a daily visual inspection of the product to identify any damage to the product at an early stage.

Check the product for cracks and damage, in particular on the clamping and end-stop surfaces.

The rubber on the clamping element also needs to be examined for cracks and signs of damage.

A check is also required to ensure that all fixing screws are tightened down.

If damage is detected, the relevant components must be exchanged immediately for genuine spare parts from the manufacturer.

Complete cleaning of the product is required if heavily soiled [see »Cleaning« chapter].

11.5 Lubricating the product



DANGER

Serious injuries caused by workpiece being ejected centrifugally due to insufficient lubrication of the product!

- Maximum clamping force is reduced by approximately 20% if lubrication is insufficient.
- Always comply with the maintenance intervals [see »Maintenance schedule« chapter].

Lubrication takes place every time the system is cleaned, maintained or assembled, and also when required.

1. Dismantle the product for lubrication purposes. Consult the »Cleaning« chapter for details of the level of disassembly required.
2. At all lubrication points, remove escaping, consumed or surplus grease, and dispose of it in accordance with locally enforceable legislative provisions.
3. After lubrication, perform the entire stroke several times.

11.6 Use of lubricants

To achieve ultimate performance from the products, use the specified lubricants.

Only use grease that complies with the fundamental requirements governing adhesion, pressure resistance and solubility in coolants. Furthermore, there must be no particles of dirt in the grease because these cause an operational malfunction if they come between two interference fit surfaces. For this, the following lubricants are recommended:

GP 355 universal grease

[see the HAINBUCH product catalogue]

Alternatively:

Lubricants	Manufacturer	Product designation
Grease	MicroGleit	GP 355
	Klüber	QNB 50
	Zeller & Gmelin	DIVINOL SD24440
	Bremer & Leguill	RIVOLTA W.A.P.

Table 8: Selection of lubricants



NOTE

Malfunction of the product due to a combination of different greases!

- Never mix different greases with one another.
- Clean the product completely before using a different grease.

12 Disposal

If no agreement exists for return or disposal, send dismantled components off for recycling.



NOTE

Substantial damage to the environment can result from incorrect disposal of environmentally hazardous substances!

- Lubricants, auxiliary materials and operating fluids are governed by legislation for the processing of special-category waste: All disposal to be performed by authorized waste disposal specialists.

Catch exchanged oils and greases in suitable containers and dispose of them in accordance with applicable local provisions.

The local municipal authority or specialist waste disposal companies can provide information about environmentally compliant disposal.

13 Faults

The following chapter describes possible causes for faults, and the work involved in remedial action.

If multiple faults occur, shorten the maintenance intervals in accordance with actual load levels.

Contact the manufacturer if faults occur that cannot be remedied by following these instructions [see »Contact« chapter].

13.1 Procedure with faults

This applies in all cases:

1. With faults that constitute an immediate danger to people or capital equipment, press the Emergency Stop button on the machine tool immediately.
2. Establish the cause of the fault.
3. If troubleshooting requires work to be conducted in the danger area, switch the machine tool into set-up mode.
4. Notify the person on location of the fault immediately.
5. Depending on the type of fault, get it remedied by authorized and appropriately skilled specialists.



INFORMATION

The troubleshooting table in the following section provides information about who is authorized to remedy a given fault.

6. In the event of a fault not caused by the product, the fault may be caused by something close to the machine tool. For this, refer to the operating instructions of the machine tool.

13.2 Fault table

Fault	Possible cause	Remedial action	Remedied by
Defective axial strokes in the clamping device	Dirt in the parts in the power flow	Remove and clean the clamping element and, if necessary, remove, dismantle and clean the clamping device	Skilled specialist
	Defective drawtube adapter	Discussion with the manufacturer	Manufacturer
	Incorrect drawtube position	Check drawtube position and align with the clamping device	Skilled specialist
Clamping element cannot be swapped in or out	Defective axial strokes in the clamping device	See fault »Defective axial strokes in the clamping device«	
Clamping force is too weak	Workpiece outside the clamping width diameter	Use a suitable clamping element diameter	Skilled specialist
	Axial actuating force on drawtube too weak	Check machine setting and correct if necessary	
	Stroke limitation by the workpiece end-stop	Use an appropriate workpiece end-stop	
	Incorrect lubrication condition	Check lubrication of the clamping device and correct if necessary	
Clamping force is too high	Axial actuating force on drawtube too high	Check machine setting and correct if necessary	Skilled specialist
Geometry deviation on the workpiece	Axial run-out error on the clamping device	Check axial run-out of the clamping device and correct if necessary	Skilled specialist
	Face run-out error of the clamping device	Check face run-out of the clamping device and clean the mating surfaces if necessary	
	Dirty end-stop area	Remove the workpiece end-stop and clean the mating surfaces	
	Dirty coupling area in the clamping element	Remove the clamping element, clean the coupling area and the clamping element	
	Dirty clamping taper	Remove the clamping element and clean the clamping taper	

Fault	Possible cause	Remedial action	Remedied by
	Geometry error on the workpiece due to incorrect type of clamping element	Use a suitable clamping element	
	Elastic distortion	Reduce the clamping force to the level applicable for the clamping device and the workpiece Check the workpiece material	
Indentations on the clamping surface	Clamping force is too high	Reduce the clamping force to the level applicable for the clamping device and the workpiece	
	Incorrect type of clamping element	Use a suitable clamping element	
	Dirty clamping element	Clean the clamping element	Skilled specialist
	Damaged clamping element	Replace the clamping element	
	Dimensional difference between workpiece diameter and clamping bore is too big	Use clamping element with a suitable clamping diameter	

Table 9: Fault table

13.3 Commissioning after a fault has been remedied

After the fault has been remedied, perform the following steps to recommission it:

1. Reset the emergency stop equipment.
2. Acknowledge the fault on the control unit of the machine tool.
3. Ensure that no-one is in the danger area.
4. Start the machine tool.

14 Annex

14.1 Contact

The following hotlines are available to you for orders, schedule tracking and emergencies.

Order hotline

Ordered quickly, supplied swiftly. Just phone:

+49 7144. 907-333

Tracking hotline

Current status of your order? Just call:

+49 7144. 907-222

24 hour emergency phone line

Has a system crash occurred, or some other technical emergency?

Our experts are there for you around the clock:

+49 7144. 907-444

For advice or help, you can contact the sales partners and service staff listed in www.hainbuch.com.

14.2 Manufacturer certification

Manufacturer certification is supplied with the product and with this manual.

Index directory

A

- Accessories, needed
 - Segmented clamping bushing 26
- Accessories, optional
 - Adapter for checking the air system
 - 26
 - hs dock actuating unit 26
 - ms dock stationary actuating unit . 27
 - Rotating ms dock actuating unit.... 27

Accessories, required

- Drawtube adapter 26
- Workpiece end-stop 26

Accessories, spindle flange required 26

B

- Balancing quality 23
- Brief description 25

C

- Checking the total stroke 63
- Cleaning..... 82
- Copyright 9

D

- Definition of terms 8

E

- End of production 66
- Environmental protection 21

F

- Fault table 89
- Faults 88

H

- Hazards 16

I

Installation

- Changing part 57
- Clamping element..... 55
- Preparation of the machine..... 39
- Preparation of the product 40
- Product 39

Installation of spindle flange..... 44, 46

Installation safety 35

Intended use 13

K

- Key to symbols..... 7

L

- Layout 25
- Liability 9
- Limits of use 28
- Lubricants..... 21, 86

M

- Maintenance schedule 81
- Misuse..... 14

O

- Operating conditions 24

P

- Packaging 33
- Performance values 23
- Personnel requirements 12
 - Electricians..... 13
 - Hydraulics specialist 12
 - Pneumatics specialist 12
 - Skilled specialist..... 12
 - Trainees 13

Preservation 34

Protective equipment

- Hair net 16
- Hard hat 16
- Protective gloves..... 16
- Protective goggles 16
- Safety footwear 16
- Workplace clothing..... 15

R

Removal

- Clamping element 72
- Preparation of the machine 69
- Product..... 75
- Spindle flange 78

Removal of changing parts..... 69

S

Safety

- Commissioning 61
- General 11
- Maintenance 80
- Removal..... 67
- Transport, packaging, storage 31

Scope of delivery..... 9

Screw tightening torques

Aluminum components	38	Transport inspection.....	32
Metric control threads	38	Transportation, internal	33
Spare parts	10	Type designation.....	24
Speed	24	U	
Storage	34	Unpacking	33
Symbols on the packaging.....	32	Use.....	28
T		W	
Technical data.....	22	Warranty.....	10
Tests	63		



HAINBUCH GMBH · SPANNENDE TECHNIK

Postfach 1262 · 71667 Marbach / Erdmannhäuser Strasse 57 · 71672 Marbach · Germany

Tel. +49 7144.907-0 · Fax +49 7144.18826 · verkauf@hainbuch.de · www.hainbuch.com

24 hour emergency phone line + 49 7144.907-444