

# Operating instructions

[incl. installation manual]

MANOK plus

EN

**Translation of the original operating instructions**

## Contents

1	General.....	7
1.1	Information about this manual.....	7
1.2	Key to symbols.....	7
1.3	Definition of terms.....	8
1.3.1	Release setting.....	8
1.3.2	Complete clamping reserve.....	8
1.4	Limitation of liability.....	9
1.5	Copyright.....	9
1.6	Scope of delivery.....	9
1.7	Spare parts and accessories.....	10
1.8	Warranty terms.....	10
2	Safety.....	11
2.1	Responsibility of the operator.....	11
2.2	Personnel requirements.....	11
2.3	Intended use.....	13
2.4	Personal protective equipment.....	15
2.5	Particular hazards.....	16
2.6	Other safety instructions.....	17
2.7	Screws.....	19
2.8	Functionality.....	19
2.9	Environmental protection.....	20
3	Technical data.....	21
3.1	General information.....	21
3.2	Performance values.....	21
3.3	Balancing quality.....	21
3.4	Speed.....	22
3.5	Clamping force diagram.....	22
3.5.1	Size 65.....	23
3.6	Conversion of actuating torque to actuating force.....	23
3.6.1	Nomenclature.....	23
3.6.2	Calculation.....	24
3.6.3	Sample calculation.....	24
3.6.4	Diagram of actuating torque to actuating force.....	25
3.7	Operating conditions.....	25
3.8	Type designation.....	25
4	Layout and function.....	26
4.1	Overview and brief description.....	26
4.2	Accessories required.....	27
4.2.1	Clamping head.....	27
4.2.2	Workpiece end-stop.....	27
4.3	Optional accessories.....	27

4.3.1	Jaw module .....	27
4.3.2	Magnet module.....	27
4.3.3	MANDO Adapt.....	28
4.3.4	Morse taper adaptation.....	28
4.3.5	Face driver adaptation.....	28
4.3.6	vario part end-stop system .....	28
4.3.7	vario quick end-stop system .....	29
4.3.8	Torque wrench kit.....	29
4.4	Special aids.....	29
4.4.1	Key .....	29
4.4.2	Manual changing fixture .....	29
4.4.3	Pneumatic changing fixture .....	29
5	Use and limits of use .....	30
5.1	Use.....	30
5.2	Limits of use.....	30
5.2.1	Nomenclature .....	31
5.2.2	First limit [workpiece length] .....	33
5.2.3	Second limit [workpiece mass] .....	33
5.2.4	Third limit [clamping length] .....	34
5.2.5	Fourth limit [forces] .....	34
5.2.6	Sample calculation .....	46
6	Transport, packaging, storage.....	50
6.1	Safety, transport, packaging, storage .....	50
6.2	Symbols on the packaging.....	51
6.3	Transport inspection.....	51
6.4	Unpacking and internal transportation.....	52
6.5	Packaging .....	52
6.6	Storage .....	53
6.7	Preservation.....	53
6.8	Return to storage .....	53
7	Installation .....	54
7.1	Installation safety .....	54
7.2	Preliminary remarks .....	55
7.3	Screw tightening torques.....	56
7.4	Preparation of the machine for installation .....	57
7.5	Installation of the product.....	58
7.5.1	Compatibility check.....	58
7.5.2	Preparation of the product .....	58
7.5.3	Installation of the product on the machine .....	59
7.6	Installation of the clamping element.....	61
7.7	Installation of the changing parts .....	63
7.7.1	Installation of the variant, screwed directly .....	64
7.7.2	Installation of the variant x-times with axial screw connection.....	64

7.7.3	Installation of the variant x-times with bayonet axial screw connection .....	65
7.7.4	Installation of the central variant with axial screw connection .....	67
7.7.5	Installation of the radially clamped variant .....	67
7.8	Aligning the clamping device with the test specimen .....	69
8	Commissioning .....	70
8.1	Commissioning safety .....	70
8.2	Checking the total stroke .....	71
8.3	Tests .....	72
8.4	Workpiece .....	73
8.4.1	Clamping the workpiece .....	74
8.4.2	Releasing tension on the workpiece .....	76
8.5	Procedure after a collision .....	77
9	Activities after end of production .....	78
10	Removal .....	79
10.1	Safe removal .....	79
10.2	Preparing the machine for removal .....	81
10.3	Removal of the changing parts .....	81
10.3.1	Removal of the variant with direct screw connection .....	82
10.3.2	Removal of the variant x-times with axial screw connection .....	82
10.3.3	Removal of the variant x-times with axial screw connection bayonet .....	83
10.3.4	Removal of the central variant with axial screw connection .....	85
10.3.5	Removal of the radially clamped variant .....	86
10.4	Removal of the clamping element .....	87
10.5	Removal of the product .....	89
10.5.1	Removal of the product from the machine .....	90
11	Maintenance .....	92
11.1	Maintenance safety .....	92
11.2	Maintenance schedule .....	92
11.3	Cleaning .....	93
11.4	Visual inspection .....	96
11.5	Lubricating the product .....	97
11.6	Use of lubricants .....	98
12	Disposal .....	99
13	Faults .....	100
13.1	Procedure with faults .....	100
13.2	Fault table .....	101
13.3	Commissioning after a fault has been remedied .....	102
14	Annex .....	103
14.1	Contact .....	103
14.2	Manufacturer certification .....	103

**Directory of tables**

Table 1:	Technical data .....	21
Table 2:	Nomenclature for conversion of actuating torque to actuating force .....	23
Table 3:	Operating conditions .....	25
Table 4:	Nomenclature application limits .....	32
Table 5:	Maximum workpiece mass .....	34
Table 6:	Scatter widths of clamping force .....	37
Table 7:	Contact forms / scenarios .....	37
Table 8:	Contact factor .....	38
Table 9:	Specific cutting forces .....	39
Table 10:	Friction coefficient for steel workpieces .....	40
Table 11:	Clamping head mass and distance of mass center of gravity of clamping head segments to the rotational axis .....	41
Table 12:	Maximum permitted tailstock force .....	43
Table 13:	Maximum permitted cutting force .....	44
Table 14:	Maximum permitted transverse force .....	45
Table 15:	Maximum permitted torque due to transverse force .....	46
Table 16:	Screw tightening torques, metric control threads .....	57
Table 17:	Screw tightening torques for aluminum components .....	57
Table 18:	Maintenance table .....	93
Table 19:	Selection of lubricants .....	98
Table 20:	Fault table .....	102

# 1 General

## 1.1 Information about this manual

This manual enables you to work safely and efficiently with the product.

This manual is part of the product and must be kept in a location directly beside the product that is accessible to the personnel at all times. The personnel must have read this manual carefully and understood its contents before starting any work. The basic requirement for safe work is compliance with all stipulated safety notices and work-related instructions in this manual.

If the product is passed onto a third party, this manual must accompany it.

Illustrations in this manual are there to facilitate a basic understanding, and may differ from the actual design configuration of the product.



### **WARNING**

#### **Serious injuries caused by individual products or by inappropriate combinations of them!**

- Read and pay attention to all operating instructions for individual products and combinations of them.

## 1.2 Key to symbols

Safety instructions in this manual are designated by symbols. The safety notices are invoked by signal words that express the level of hazard involved.

Always comply with safety notices and exercise caution to avoid accidents, injury to people and damage to materials.

### **Safety notices**



### **DANGER**

... indicates an immediate and hazardous situation that can lead to death or serious injury if not avoided.



### **WARNING**

... indicates a potentially hazardous situation that can lead to death or serious injury if not avoided.



### **CAUTION**

... indicates a potentially hazardous situation that can lead to moderate or slight injuries if not avoided.



### **NOTE**

... indicates a potentially hazardous situation that can lead to damage to materials if not avoided.

## Tips and recommendations



### INFORMATION

... highlights useful tips and recommendations as well as information for efficient and problem-free operation.



... refers to other documents relating to personal and general safety.

Warning symbols may appear on the product or its components.

Always pay attention to warning symbols, and exercise caution to avoid accidents, injury to people and damage to materials.



... warns of stored energy [for example involving springs].



... warns of hand injuries.



... draws attention to the fact that the operating instructions of the product must be read.

## 1.3 Definition of terms

### 1.3.1 Release setting

Release setting means that the clamping device is released. If the clamping device is released, this also releases the workpiece.

### 1.3.2 Complete clamping reserve

Complete clamping reserve means that the clamping device is clamped without a workpiece. The complete stroke has been used up, which means that the clamping device is therefore at the limit position for clamping reserve.



## 1.4 Limitation of liability

All details and notices in this manual were compiled with due reference to applicable standards and specifications, state-of-the-art technology and our many years of expertise and experience.

The manufacturer accepts no liability for damage arising from any of the following:

- Non-compliance with this manual
- Unintended use
- Use of untrained personnel
- Autonomous conversion work
- Technical modifications
- Use of non-approved spare parts
- Use of non-approved accessories
- Installation and use of clamping elements not made by the manufacturer

Subject to any commitments agreed to in the supplier contract, the General Terms & Conditions of Business and the delivery terms of the manufacturer and all legislative stipulations valid at the time of conclusion of this contract.

## 1.5 Copyright

This manual is protected by copyright, and are only intended for internal use.

The dissemination of this manual to third parties, reproductions in any shape or form - even in part - as well as commercial use and/or communication of their contents are prohibited for anything other than internal use, except with the written consent of the manufacturer.

Infringements oblige the offending party to pay compensation. Without restriction on further claims.

## 1.6 Scope of delivery

The scope of delivery of this product includes:

- MANOK plus
- Actuating key
- The operating instructions

Additionally needed and included as optional items in the scope of delivery:

- Clamping head
- Workpiece end-stop
- Changing fixture

## 1.7 Spare parts and accessories



### WARNING

**Serious injuries can be caused by incorrect or defective spare parts!**

- Always use genuine spare parts made by the original manufacturer.



### WARNING

**Serious injuries can be caused by incorrect or defective clamping elements!**

- Always use genuine clamping elements made by the original manufacturer.



### NOTE

**Damage, malfunctions or total failure of the product or the machine tool caused by an incorrect or defective spare parts!**

- Always use genuine spare parts made by the original manufacturer.



### NOTE

**Damage, malfunctions or total failure of the product or the machine tool caused by an incorrect or defective clamping elements!**

- Always use genuine clamping elements made by the original manufacturer.

Spare parts and accessories can be sourced from contract dealers or directly from the manufacturer [see »Contact« chapter].

Without exception, wearing parts and components in contact with the workpiece are not covered by warranty.

## 1.8 Warranty terms

The warranty terms are included in the manufacturer's General Terms & Conditions of Business.

## 2 Safety

This section provides an overview of all the important safety aspects for optimum protection of personnel, and for safe and problem-free operation.

### 2.1 Responsibility of the operator

The product is used in the industrial sector. The operator of the product is therefore governed by the provisions of Health & Safety at Work legislation.

As well as the safety notices in this manual, the area of use of the product must also comply with locally applicable safety, accident prevention and environmental protection specifications as well as those in the manual for the machine tool.

No modifications must be made to the product. The operator is wholly and solely responsible for any resultant personal injury and/or damage to materials.

Excepted from this are changing parts that HAINBUCH approved explicitly for autonomous machining, but specified limits must never be exceeded.

The achievable clamping forces may vary as a result of the maintenance status of the product [lubrication status and level of contamination] [see »Cleaning« and »Clamping force diagram« chapters].



#### **DANGER**

**Serious injuries caused by parts being ejected centrifugally if clamping force is insufficient!**

- Conduct a clamping force measurement with an appropriate measuring device.
- Clamp the workpiece and conduct a tapping test.

### 2.2 Personnel requirements



#### **WARNING**

**Serious injuries caused by incorrect handling of the product by insufficiently skilled or trained personnel!**

- All activities must be performed by skilled staff from the relevant specialist field.



**WARNING**

**Serious injuries caused by unauthorized presence of unauthorized personnel in the working area!**

- Keep unauthorized people away from the working area.
- If in doubt, speak to people and direct them to leave the working area.
- Interrupt work until unauthorized people have left the working area.



**NOTE**

**Serious damage to materials caused by incorrect handling of the product by insufficiently skilled or trained personnel!**

- All activities must be performed by skilled staff from the relevant specialist field.

This manual name the following skills sets required for various different areas of activity:

**Skilled specialist**

Skilled specialists, due to their professional training, knowledge and experience and awareness of applicable provisions, are capable of carrying out the work entrusted to them and independently to identify and avoid potential hazards.

**Hydraulics specialist**

Hydraulics specialists are trained in the specific task profile for which they are employed, and are familiar with the relevant standards and legislative provisions.

Due to their vocational training and experience, hydraulics specialists can work on hydraulic systems and can independently identify and avoid potential hazards.

**Pneumatics specialist**

Pneumatics specialists are trained in the specific task profile for which they are employed, and are familiar with the relevant standards and legislative provisions.

Due to their vocational training and experience, pneumatics specialists can work on pneumatic systems and can independently identify and avoid potential hazards.

**Electricians**

Electricians are trained in the specific task profile for which they are employed, and are familiar with the relevant standards and legislative provisions.

Due to their vocational training and experience, electricians can work on electrical systems and can independently identify and avoid potential hazards.

## **Trainees**

Trainees can only work on the machine under the supervision and direction of staff skilled in the relevant specialist field.

The only people admitted as personnel are those who can reasonably be expected to carry out their work to a reliable standard. People whose response capabilities are impaired, for example by drugs, alcohol or medication, are prohibited. For the selection of personnel, pay attention to the stipulations applicable at the place of work governing age and specific vocational requirements.

## **2.3 Intended use**

The product is only intended for installation in a CE-compliant machine tool with a separating set of guards.

The product is only intended for the type of use described in this manual [see »Use« chapter]. Furthermore, an extended form of use can be agreed contractually between manufacturer and operator.

Only skilled staff from the appropriate specialist fields may install, operate, maintain and clean the product [see »Personnel requirements« chapter].

Never exceed the technical values stipulated for the product [see »General information« and »Operating conditions« chapters].

Furthermore, never exceed the limits for use of the product [see »Limits of use« chapter].

Maintain the product at regular intervals [see »Maintenance schedule« chapter].

When used for its intended purpose, the operational safety of the product is assured, subject to compliance with relevant safety stipulations, to the full extent foreseeable.

Intended use also includes compliance with all stipulations in this manual.

Any form of use beyond the scope of intended use, or other forms of use of the product, is considered as misuse, and can lead to dangerous situations.



## **DANGER**

### **Serious injuries caused by misuse of the product!**

- Only in a CE-compliant machine tool with a separating set of guards.
- Only use for the type of use indicated [see »Use« chapter].
- Only skilled staff from the appropriate specialist fields may use the product [see »Personnel requirements« chapter].
- Never exceed the technical data indicated on the product [see »General information« and »Operating conditions« chapters].
- Never exceed the limits for use of the product [see »Limits of use« chapter].
- Maintain the product at regular intervals [see »Maintenance schedule« chapter].
- Only use with approved attachments and/or clamping elements.



## **NOTE**

### **Damage to materials caused by incorrect use of the product!**

- Only in a CE-compliant machine tool with a separating set of guards.
- Only use for the type of use indicated [see »Use« chapter].
- Only skilled staff from the appropriate specialist fields may use the product [see »Personnel requirements« chapter].
- Never exceed the technical data indicated on the product [see »General information« and »Operating conditions« chapters].
- Never exceed the limits for use of the product [see »Limits of use« chapter].
- Maintain the product at regular intervals [see »Maintenance schedule« chapter].
- Only use with approved attachments and/or clamping elements.

Claims of all kinds will be rejected that are due to unintended use.

Here are some examples of unintended use of the product

- If workpieces are not clamped properly.
- If people fail to observe the safety stipulations when working on the product, and failing to use additional protective equipment, for example to machine clamped workpieces.

- If the product is used on machines, workpieces and/or changing parts for which it is not intended.

## 2.4 Personal protective equipment

During work, it is essential to wear personal protective equipment to minimize the health hazards.

Always wear the required personal protective equipment when working on any given job.

Always pay attention to any notices about personal protective equipment displayed in the working area.

### Always wear



#### Workplace clothing

Workplace clothing should be close-fitting, with low tear-resistance, narrow cuffs and no protruding parts. It serves primarily to protect the wearer from coming into contact with moving machine parts. Do not wear rings, chains or other jewelry.



#### Safety footwear

To protect the wearer from any heavy items that may fall, and from losing their footing on slippery ground.



#### Protective goggles

To protect the eyes from projectile parts and liquid splashes.



#### Hair net

To protect long hair from getting snagged in rotating parts on the machine tool.

### Additional personal protective equipment



When carrying out certain work, additional personal protective equipment is required. Separate reference is made to this in the individual chapters of this manual. The following section explains these additional items of personal protective equipment:

#### Protective gloves

To protect the hands from friction, chafing, stabbing or deeper injuries and from contact with hot surfaces.



## Hard hat

To protect against falling and projectile parts and materials.

## 2.5 Particular hazards

The following section names residual risks resulting from the installation of the product in a machine tool. In all cases, the residual risks detected during a risk assessment of the machine tool need to be named by the operator.

Pay attention to the safety instructions named here, as well as the warning notices in other chapters of these operating instructions to reduce the risk of health hazards and to prevent dangerous situations.

### Moving parts



#### WARNING

**Serious injuries caused by touching rotating and/or moving parts!**

- Do not open guards while the system is operating.
- During operation, do not reach for rotating and/or moving parts.
- Pay attention to the gap dimensions of moving parts.
- Before opening the guards, ensure that none of the parts are moving any more.

### Stroke



#### WARNING

**Serious crushing injuries caused by the stroke of the product!**

- Never reach into an area where moving parts are operating.

### Insufficient workpiece clamping



#### DANGER

**Serious injuries caused by parts being ejected centrifugally if level of workpiece clamping is insufficient!**

- Workpiece blanks must not be outside the clamping width diameter.
- Clamping of the workpiece must not be outside the defined limits [see »Limits of use« chapter].
- Do not exceed the maximum performance values [see »General information« chapter].



## Insufficient workpiece clamping



### WARNING

**Serious injuries caused by breakage of individual components of the product at excessive tightening torque!**

- Check tightening torque on a regular basis and adjust if necessary.

## Sharp-edged parts



### WARNING

**Serious cut injuries caused by sharp-edged parts and burrs!**

- All installation of individual parts must be performed by skilled staff from the relevant specialist field.
- Also wear the following items of personal protective equipment, in addition to the basic equipment:



## 2.6 Other safety instructions



### DANGER

**Serious injuries caused by workpieces being ejected centrifugally when clamping unit is released while still rotating!**

- Never release the clamping of the workpiece while it is still rotating.



### WARNING

**Serious head injuries caused by bending into the working area of the machine!**

- Only ever bend into the working area of the machine if there are no cutting tools or sharp objects in it, or if these are covered.
- Never move body parts under parts in the working area of the machine with the potential to drop down.



## **WARNING**

### **Serious injuries caused by snagging body parts on the rotating machine spindle!**

- Never reach into the product while the machine spindle is still rotating.
- Before working on the product, ensure that the machine spindle is unable to start up.



## **WARNING**

### **Serious injuries caused by reaching into slots and bores!**

- Never reach into slots or bores.



## **WARNING**

### **Serious injuries caused by workpieces dropping or the clamping unit getting released!**

- Only unclamp the workpiece if it is protected against falling.



## **WARNING**

### **Serious injuries caused by the use of damaged products or by their components and accessories!**

- Check products or their components and accessories on a regular basis for visible signs of damage [see »Inspections« and »Cleaning« chapters].
- Use of damaged products, their damaged components and/or their damaged accessories is prohibited.
- Report damage to the operator immediately.
- Damaged components / accessories must be replaced with genuine spare parts / accessories made by the manufacturer.



## **CAUTION**

### **Cut injuries caused by sharp edges and burrs resulting from wear and/or repeated rework!**

- Remove sharp edges and burrs.
- If necessary, replace worn components with genuine parts made by the manufacturer.



**NOTE**

**Serious damage to materials / the machine tool / the product caused by workpieces being ejected centrifugally if clamping is released while they are still rotating!**

- Never release the clamping of the workpiece while it is still rotating.



**NOTE**

**Damage to materials caused by untightening the wrong screws!**

- Do not open the screws secured with sealing lacquer.

## 2.7 Screws



**WARNING**

**Serious injuries caused by radially installed screws being ejected centrifugally if installed incorrectly / poor handling!**

- Do not open the screws secured with sealing lacquer.
- Screws and threaded pins fitted radially to the product that were bonded with adhesive need to be secured again using a standard, medium-strength screw adhesive and tightened to the specified tightening torque [see nomenclature or the »Screw tightening torques« chapter]. Before reinstallation, clean and degrease the screw and internal thread.
- Radially mounted screws and threaded pins that were not bonded with sealing lacquer or an adhesive need to be tightened back down to the specified tightening torque [see nomenclature or the »Screw tightening torques« chapter].
- If in doubt, contact the manufacturer immediately to determine how best to proceed.

## 2.8 Functionality



**WARNING**

**Serious injuries caused by severe contamination of the product!**

- Always comply with the cleaning instructions and intervals [see »Cleaning« chapter].

## 2.9 Environmental protection



### NOTE

**Substantial damage to the environment can result from non-compliant handling or incorrect disposal of environmentally hazardous substances!**

- If environmentally hazardous substances enter the environment accidentally, take immediate remedial action.
- If in doubt, notify the relevant municipal authorities about the incident.

The following environmentally hazardous substances are used:

### **Lubricants, auxiliary materials and operating fluids**

Lubricants such as grease and oil can contain toxic substances. These must not enter the environment.

Dispose of environmentally hazardous substances properly [see »Disposal« chapter].

### 3 Technical data

#### 3.1 General information

Size	Clamping range [mm]	Axial release stroke [mm]	Axial clamping reserve [mm]	Radial opening stroke in Ø [mm]	Radial reserve stroke in Ø [mm]	Total weight [kg]	Dimensions [length x width x height] [mm]	Maximum tightening torque $M_A$ [Nm]	Axial clamping force $F_{ax.max.}$ [kN]	Radial clamping force $F_{rad.max.}$ [kN]
65	3-65	2.5	2	0.6	1.0	22.0	257 x 175 x 136	100	45	105

Table 1: Technical data

#### 3.2 Performance values



##### NOTE

**Material damage to the products use and/or to the machine tool caused by exceeding the maximum performance values!**

- Do not exceed the maximum performance values [see »General information« chapter].
- On all products used, do not exceed the lowest of the maximum performance values.
- Only use product in machine tools with the same performance values.



##### INFORMATION

Details of maximum performance values can be found on each product.

If, due to abrasive wear, those performance values are no long legible, refer to the operating instructions.

The achievable actuation forces may vary as a result of the maintenance status [lubrication status and level of contamination] of the product [see »Maintenance schedule« chapter].

The achievable clamping forces resulting from actuating forces must be checked at regular intervals. For this, structural clamping force measurements must be performed.

The clamping force measured must be in the approved range [see »Clamping force diagram« chapter].

#### 3.3 Balancing quality

The product is not balanced ex-factory because it is designed for stationary operation.

### 3.4 Speed

The product was designed for stationary operation.



#### **WARNING**

**Serious injuries caused by imbalance during continuous rotational operation!**

- Do not operate the product in continuous rotation.
- Rotate the product at no more than max. 60 rpm.
- From all of the maximum speeds indicated for the combined products, always remain at the lowest of those maximum speeds.

### 3.5 Clamping force diagram

The clamping force diagram indicates the permitted range in which the radial clamping force is permitted to move in response to axial actuating force.

The clamping force diagram indicates the influences of friction and of the clamping diameter.



#### **WARNING**

**Serious injuries caused by insufficient clamping force!**

- The values measured for radial clamping force  $F_{rad}$  must be within the permitted range.
- If the values recorded are outside the permitted range, the product must be cleaned [see »Cleaning« chapter] and another clamping force test must be conducted.
- If the values recorded after cleaning is completed are outside the permitted range, you should contact the manufacturer.

### 3.5.1 Size 65

#### Sample scan:

At an actuating torque  $M_A$  of 55 kN, the radial clamping force  $F_{rad}$  is in a range between 36 kN and 65 kN.

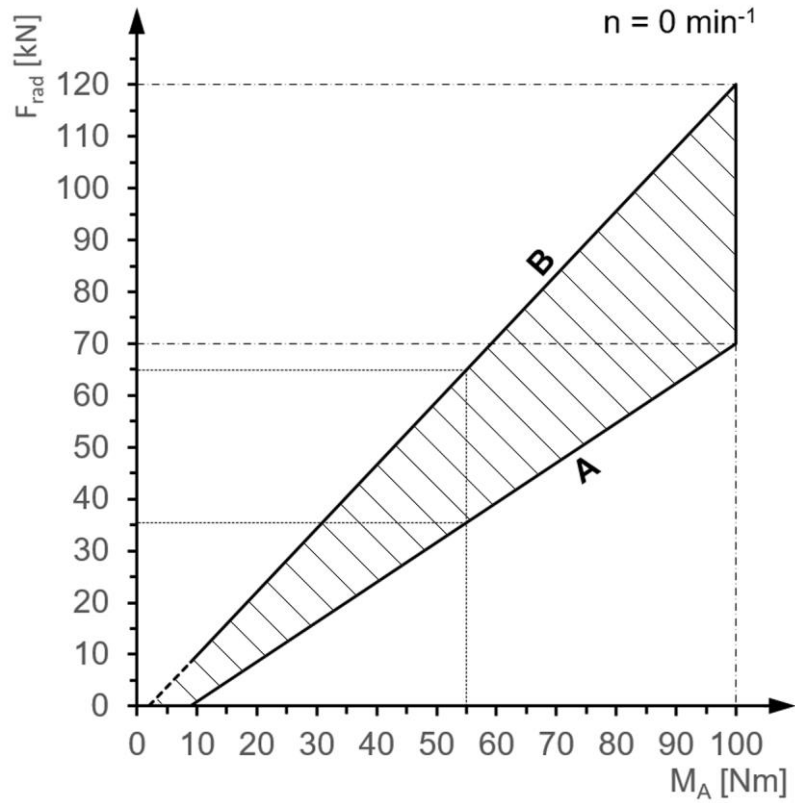

- A lower limit value
- B upper limit value

### 3.6 Conversion of actuating torque to actuating force

To find the right settings, you need to convert from actuating torque to actuating force or vice versa.

#### 3.6.1 Nomenclature

Brief designation	Unit	Explanation
$F_{ax}$	$kN$	Axial actuating force
$F_{ax\ max}$	$kN$	Maximum axial actuating force
$M$	$Nm$	Actuating torque
$M_{max}$	$Nm$	Maximum actuating torque

Table 2: Nomenclature for conversion of actuating torque to actuating force

### 3.6.2 Calculation

The following formula should be used to determine the actuating torque that needs to be set to achieve a defined level of actuating force:

$$M = \frac{M_{max} * F_{ax}}{F_{ax max}}$$



#### INFORMATION

The maximum actuating torque  $M_{max}$  and the maximum actuating force  $F_{ax max}$  can be taken from the »General information« chapter.

The following formula should be used to determine the actuating force present at a given actuating torque setting:

$$F_{ax} = \frac{F_{ax max} * M}{M_{max}}$$



#### INFORMATION

The maximum actuating torque  $M_{max}$  and the maximum actuating force  $F_{ax max}$  can be taken from the »General information« chapter.

### 3.6.3 Sample calculation

#### Clamping head chuck

- MANOK plus size 65

#### Actuating force

- Actuating force to be set  $F_{ax} = 27kN$

#### Calculation

$$M = \frac{M_{max} * F_{ax}}{F_{ax max}} = \frac{100Nm * 27kN}{45kN} = 60Nm$$



### 3.6.4 Diagram of actuating torque to actuating force

#### Scan sample 1:

At an actuating torque of 70 Nm, the axial tensioning force for size 65 is 31 kN.

#### Scan sample 2:

At a required axial actuating force of 20 kN, an actuating torque of 45 Nm must be applied for size 65.

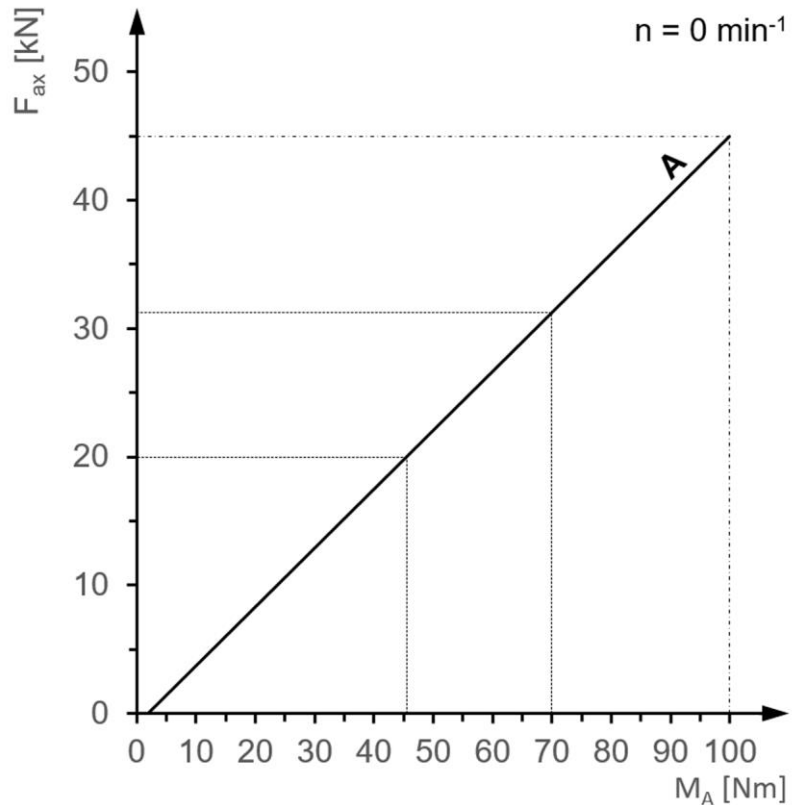

A Size 65

### 3.7 Operating conditions

Indication	Value	Unit
Ambient temperature range	15 - 65	°C
Workpiece temperature	≤ 80	°C
Humidity	≤ 80	%

Table 3: Operating conditions

### 3.8 Type designation

The type designation is on the product and it includes the following indications:

- Manufacturer
- Product designation
- ID number [marked with a # symbol]
- Build year
- Maximum actuating force  $F_{ax\ max}$  [kN]
- Maximum clamping force  $F_{rad\ max}$  [kN]
- Maximum actuating torque  $M_{max}$  [Nm]

## 4 Layout and function

### 4.1 Overview and brief description

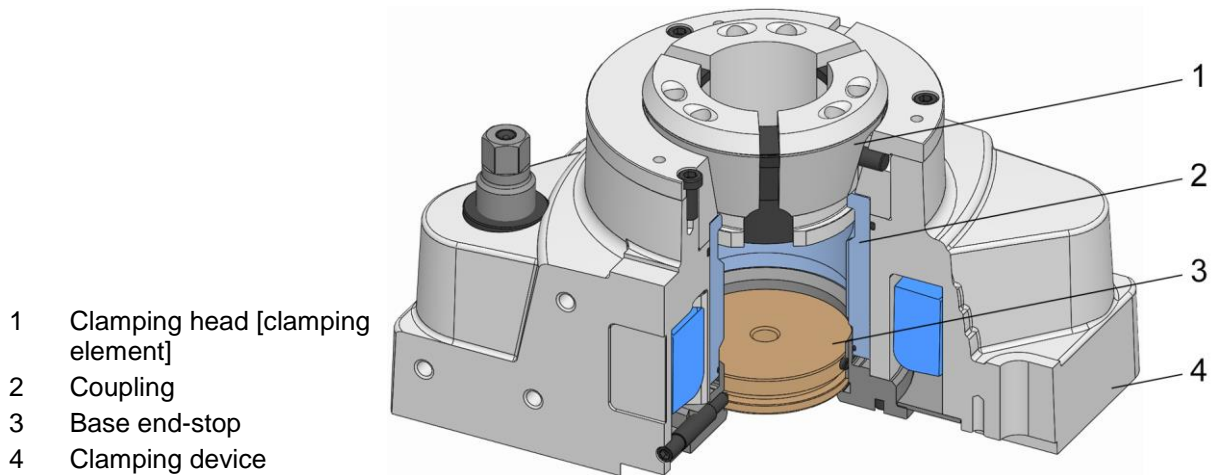

- 1 Clamping head [clamping element]
- 2 Coupling
- 3 Base end-stop
- 4 Clamping device

The clamping device is a hand-actuated stationary chuck.

The clamping device is designed as an end-stop chuck.

The clamping device is screwed to the machine table.

It is operated with the help of an actuating key.

The clamping element was installed in the clamping device with an appropriate changing fixture and it clamps the workpiece being machined.

The workpiece end-stop can be screwed to the base end-stop, screwed on directly, or fitted as a front-mounted end-stop.

The clamping device functions on the pull-back principle.

When clamping, the clamping element performs an axial movement towards the workpiece end-stop.

The mobile coupling draws the clamping element into the stationary taper.

This draws the workpiece firmly up against the stationary workpiece end-stop.

This increases the rigid strength of this clamping configuration.

### 4.2 Accessories required

#### 4.2.1 Clamping head

The clamping head is there to support the workpiece being machined. It consists of hard steel and rubber segments connected by vulcanization.

Depending on workpiece requirements, various sizes of clamping head are available, also with different profiles and bores.

#### 4.2.2 Workpiece end-stop

The workpiece end-stop is produced with an end-stop dimension that reflects customer wishes.

### 4.3 Optional accessories

The following optional accessories are available for different sizes of product.

#### 4.3.1 Jaw module



The jaw module is an adaptation clamping device for the use with jaws. It enables the diameter of the jaw clamping range to be expanded.

#### 4.3.2 Magnet module

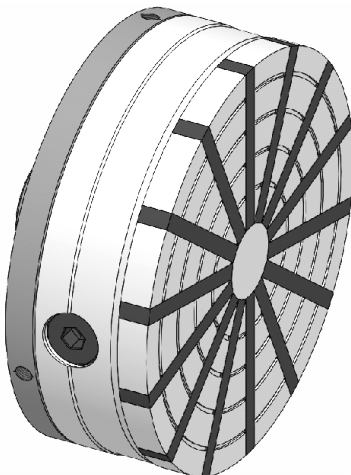

The magnet module is an adaptation clamping device for ferromagnetic materials for grinding or turning.

### 4.3.3 MANDO Adapt

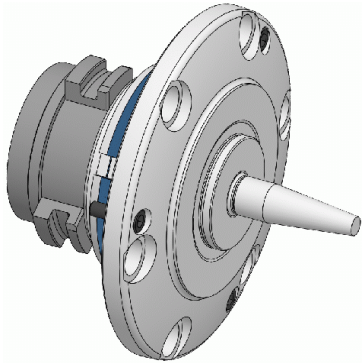

Through adaptation of the MANDO Adapt, internal clamping of the workpiece can be achieved.

### 4.3.4 Morse taper adaptation

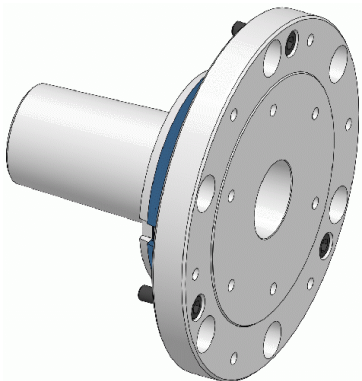

Through Morse taper adaptation, adaptation options are rendered possible with a Morse taper connection.

### 4.3.5 Face driver adaptation

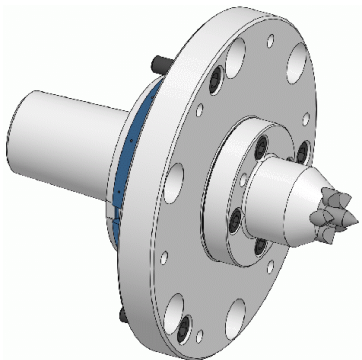

Adaptation of the face driver makes it possible to machine the entire length of the workpiece.

### 4.3.6 vario part end-stop system

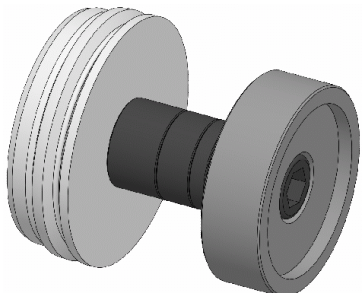

The vario part end-stop system operates on the same principle as an end-block box and its height can be adjusted in 1 mm increments with precision discs.

### 4.3.7 vario quick end-stop system

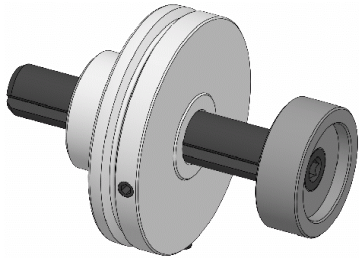

The vario quick end-stop system works with a precision trapezoidal thread that can be adjusted rapidly by varying the chuck depth.

### 4.3.8 Torque wrench kit

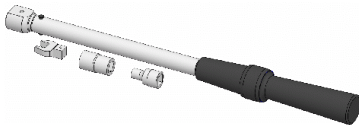

Depending on the scope of delivery, the torque wrench kit can either be supplied with the unit or provided by the customer.

## 4.4 Special aids

### 4.4.1 Key

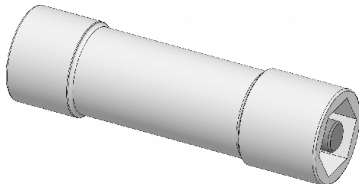

The key is there to actuate the product.

### 4.4.2 Manual changing fixture

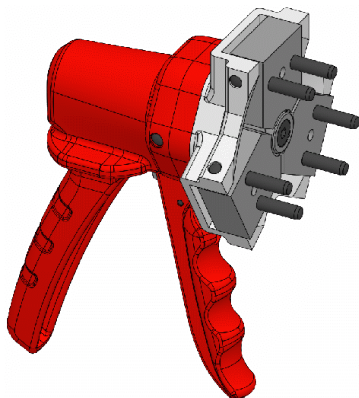

The pins on the changing fixture are installed in the changing bores in the clamping head. The changing fixture is actuated by manual force. Depending on size, the changing fixture may be designed for single-handed or for two-handed actuation. The clamping head is clamped firmly in the changing fixture and can be installed in the mounted clamping device with the help of the changing fixture.

### 4.4.3 Pneumatic changing fixture

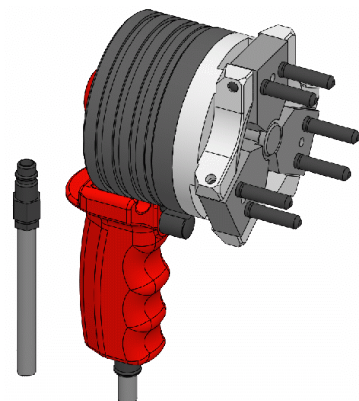

The pins on the changing fixture are installed in the changing bores in the clamping head. The changing fixture is actuated pneumatically. Depending on size, the changing fixture may be designed for single-handed or for two-handed actuation. The clamping head is clamped firmly in the changing fixture and can be installed in the mounted clamping device with the help of the changing fixture.

## 5 Use and limits of use

### 5.1 Use

The product is a clamping device that may only be used to clamp a rotationally symmetrical workpiece to enable it to be machined.

The product must only be actuated using the original actuation key.

As well as for its general field of application, this product was designed and developed for use, when necessary, in a specific and documented application [see clamping situation drawing or order confirmation].

Any other fields of application require the explicit approval of the manufacturer.

The clamping device can be used as an end-stop chuck. It can be attached directly to the base end-stop, or a workpiece end-stop can be mounted. For this, different connection points are provided on the clamping device.

The clamping device can be used as a through-chuck for machining bar stock. For this, the base end-stop must be removed.

With the help of suitable adaptation clamping devices from the manufacturer, the clamping device can rapidly be converted to suit a different clamp setting.

### 5.2 Limits of use

Limits are set on the operation of clamping head chucks in the area where workpieces are machined.

Specifically, before using these clamping head chucks, four separately independent limits need to be checked.

### 5.2.1 Nomenclature

Brief designation	Unit	Explanation
$a_p$	$mm$	Chip-cutting depth of turning operation
$c$	-	Contact factor
$D$	$mm$	Clamping diameter of clamping head
$D_B$	$mm$	Drill diameter
$d_{sp}$	$mm$	Clamping diameter
$d_z$	$mm$	Machining diameter of turning operation
$f$	$mm$	Feed / rotational movement of turning operation Feed / cutting-drilling operation
$F_{ax}$	$kN$	Axial actuating force
$F_B$	$N$	Feed force of drilling operation
$F_c$	$N$	Cutting force of drilling operation
$F_{c max}$	$N$	Maximum cutting force of drilling operation
$f_{fz}$	$N$	Clamping force supplement for rotational compensation
$F_G$	$N$	Density of workpiece
$f_n$	$mm$	Feed / rotational movement of drilling operation
$F_q$	$N$	Transverse force
$F_{q max}$	$N$	Maximum permitted transverse force
$F_{rad}$	$N$	Radial clamping force
$F_{rad erf}$	$N$	Required radial clamping force
$F_{sk}$	$N$	Clamping force to prevent the workpiece getting levered out
$F_{sz}$	$N$	Clamping force to absorb the machining forces and torques during turning and/or drilling operations towards the chuck axis
$F_t$	$kN$	Tailstock force
$F_{t max}$	$kN$	Maximum tailstock force
$k_c$	$\frac{N}{mm^2}$	Specific cutting force



Brief designation	Unit	Explanation
$L$	$mm$	Total chuck length
$L_a$	$mm$	Unclamping length
$L_g$	$mm$	Center of gravity distance between »Workpiece - clamping point«
$L_q$	$mm$	Distance, »radial bore machining - clamping point«
$L_{sp}$	$mm$	Clamping length
$L_{sp\ min}$	$mm$	The minimum clamping length required
$L_{sp\ v}$	$mm$	Total clamping length
$L_w$	$mm$	Workpiece length
$L_v$	$mm$	Clamping head, front-end length
$L_z$	$mm$	Distance between »Machining point - clamping point« when turning
$m$	$kg$	Mass of the clamping head
$M_B$	$Nmm$	Drilling operation torque
$M_q$	$Nm$	Torque due to lateral force on the chuck axis
$M_{q\ max}$	$Nm$	Maximum torque due to lateral force on the chuck axis
$m_w$	$kg$	Workpiece mass
$m_{w\ max}$	$kg$	Maximum workpiece mass
$n$	$min^{-1}$	Speed
$P$	-	Key indicators for machining
$r_s$	$m$	Distance between mass center of gravity of clamping head segment and rotational axis of the chuck
$S$	-	Clamping force scatter width factor
$\mu_a$	-	Friction coefficient in axial direction
$\mu_t$	-	Friction coefficient in radial direction

Table 4: Nomenclature application limits



The graphic in the sketch below shows the forces and moments used in the following sample calculations:

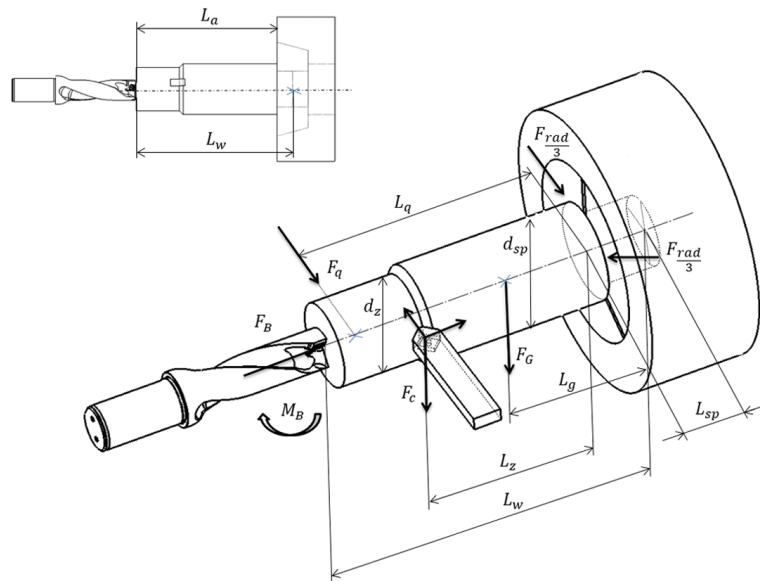

$$F_G [N] = m_w [kg] * 9.81 \left[ \frac{m}{s^2} \right]$$

### 5.2.2 First limit [workpiece length]

The maximum unclamping length that can be machined without the aid of a back rest or a tailstock is 6 times the clamping diameter.

### 5.2.3 Second limit [workpiece mass]

The maximum workpiece mass depends on the size of the clamping head chuck [see Table 5].

[These values apply to individual workpieces. Special values apply to the machining of bar stock]

Size of the clamping head chuck	Maximum workpiece mass $m_w \max [kg]$	
	Horizontal application	Vertical application
32	12	18
42	20	30
52	28	40
65	40	60
80	50	75
100	65	100
125	80	120
140	100	150

Size of the clamping head chuck	Maximum workpiece mass $m_{w max}$ [kg]	
	Horizontal application	Vertical application
160	120	180

Table 5: Maximum workpiece mass

### 5.2.4 Third limit [clamping length]

The clamping length must not be less than the minimum length required for clamping  $L_{sp} \geq L_{sp min}$ .

The front-end length of the clamping head  $L_v$  is not considered at all here.

With offset clamping bores [head bore], it may be necessary to take account of a relief groove in the clamping head when establishing the clamping length.

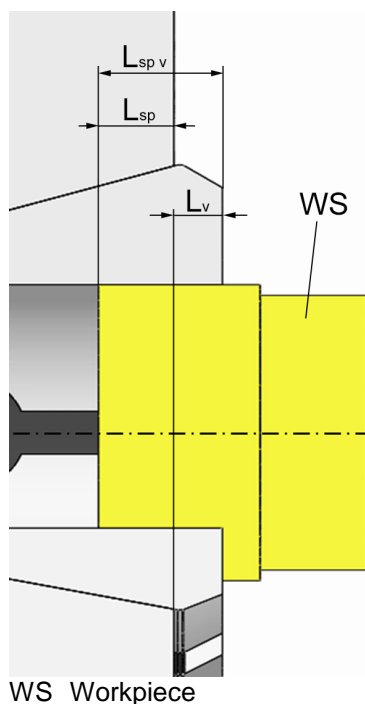

The clamping length is calculated as follows:

$$L_{sp} = L_{spv} - L_v$$

$$L_{sp} \geq 0.08 * d_{sp} \text{ applies in all cases}$$

**In addition**, the following applies:

$L_{sp} \geq 2.8mm$  [when using clamping heads with a smooth clamping bore]

$L_{sp} \geq 13mm$  [when using clamping heads with longitudinal and transverse grooves]

When using clamping heads with a closed first tunnel, different details apply which may be even higher. Consult the manufacturer for these details.

$L_{sp} \geq 7mm$  [when using clamping heads with Z serrations]

$L_{sp} \geq 5mm$  [when using clamping heads with F serrations]

If HAINBUCH uses a different and shorter clamping length in this clamping situation drawing, this will have been checked against the specific parameters for this type of application and found to be sufficient.

### 5.2.5 Fourth limit [forces]

The following sample calculation shows how to quantify the forces that are exerted on the workpiece from an external source.

The aim here is to establish whether

1. the clamping force required to absorb external forces and torques can be applied by the clamping device.

2. the clamping device is free of visible or invisible damage caused by those external forces.

The forces and torques exerted on the clamping head and, ultimately, on the chuck are, for the most part,

- a) the machining forces and torques to be absorbed
- b) the density of the workpiece itself,
- c) the centrifugal forces caused by the weight of the clamping head
- d) where necessary, tailstock forces

### Principles for the forces exerted externally



#### WARNING

**Serious injuries caused by failure to comply with the principles that govern safe machining!**

- Those principles must be maintained at all times to assure a safe machining process.

Pay attention to the following principles:

#### 1. Principle

$$F_{rad} \geq F_{rad\ erf}$$

AND

#### 2. Principle

$$F_t \leq F_{t\ max}$$

AND

#### 3. Principle

$$F_c \leq F_{c\ max}$$

[Relevant to turning and/or to axial drilling operations.]

AND

#### 4. Principle

$$F_q \leq F_{q\ max}$$

[Relevant to a radial drilling operation directed at the center and/or for the application of an equivalent load. If radial forces and the resultant torques are not directed at the center, due account of this can be taken by a quasi cutting force outside the center.]

AND

#### 5. Principle

$$M_q \leq M_{q\ max}$$

[Relevant to a radial drilling operation directed at the center and/or for the application of an equivalent load. If radial forces and the resultant torques are not directed at the center, due account of this can be taken by a quasi cutting force outside the center.]

With these principles, the assumption is that the clamping head chuck is used for a turning operation, or for an axial or

radial drilling operation on the workpiece. There is no fundamental reason why the clamping head chuck cannot also be used for other machining tasks such as bypass milling or plunge-milling. In such cases, the owner must ensure that the forces and torques that occur are comparable to the equivalent permitted values for turning or drilling, to check the reliability of the application.

#### 5.2.5.1 Further to Principle 1: $F_{rad} \geq F_{rad\ erf}$

##### **Determining the required clamping force**

The following equations are used to determine the required clamping force  $F_{rad\ erf}$  at rotational speed.

These equations apply to longitudinal turning and to face turning operations. Drilling operations on the front end of workpieces can also be calculated. Superimposed, simultaneous machining operations, for example by several tools or turret heads can also be superimposed computationally. In other words, the required radial clamping forces for individual machining operations need to be added together.

However, it is rare for axial drilling and turning operations to be superimposed because their opposing directions of rotation usually preclude them from running simultaneously.

For computational purposes, the calculation should be based upon the point with the highest forces, that is the least favorable machining moment. If in doubt, several blade engagement situations need to be checked to record the least favorable one.

If radial drilling operations are being performed, the required radial clamping force  $F_{rad\ erf}$ , and especially a check of the transverse force introduced  $F_q$  and the resultant torque  $M_q$  play a central role.

##### **Scatter widths of clamping force**

The following table illustrates clamping force scatter width factor  $S$ .

The values for the scatter width factor apply if the system is being operated in accordance with the operating instructions, that is with regular maintenance and lubrication.

Provided that the radial clamping force is measured using appropriate measuring equipment before every start-up and continuously every 100 clamping operations, it is possible to work with the reduced and 'verified' clamping force scatter width factor shown here.

Size of the clamping head chuck	Radial clamping reserve in the diameter [mm]	Clamping force scatter width factor <i>S</i>	Clamping force scatter width factor <i>S</i> 'verified'
32	1.0	2.8*	1.3
42	1.0	2.0*	1.3
52	1.0	2.0*	1.3
65	1.0	1.6*	1.3
80	1.0	1.6*	1.3
100	1.5	1.45	1.3
125	2.5	1.45	1.3
140	1.5	1.45	1.3
160	1.5	1.45	1.3

\* If as a consequence of dimensionally accurate workpieces, only 50% of the radial clamping reserve of the clamping head chuck is used up, the clamping force scatter width factor can be reduced by factor 0.85 [example: Size 52:  $S = 2.0 * 0.85 = 1.7$ ].

Table 6: Scatter widths of clamping force

### Contact factor

Consult the following tables for the contact factor, depending on the form of contact or the contact scenario.

Interference fit	Saddle fit	Edge fit
The clamping diameter of the clamping head matches the clamping diameter of the workpiece.	The clamping diameter of the clamping head is greater than the clamping diameter of the workpiece.	The clamping diameter of the clamping head is less than the clamping diameter of the workpiece.

WS Workpiece

SP Clamping element

Table 7: Contact forms / scenarios

Contact factor $c$	Machining conditions	Contact form	
		Interference fit and saddle fit	Edge fit
Smooth clamping head	Dry	1.1	1.0
	Wet* / MMS**	1.3	1.2
Clamping head with longitudinal and transverse grooves	Dry	1.1	1.0
	Wet* / MMS**	1.3	1.2
Clamping head with Z or F serrations	Dry	1.0	1.0
	Wet* / MMS**	1.2	1.1

\* Wet machining: Use of cooling lubricant [KSS]

\*\* MMS [MQL]: Use of minimum-quantity lubrication

Table 8: Contact factor

### Specific cutting forces

These are approximate values, reflecting the relatively arbitrary sub-categorization of materials. As a result, relatively large deviations from real values can be present.

For deviating workpiece materials and/or for machining tasks in the boundary area of the clamping device, the respective  $k_c$  values of the workpiece material being machine needs to be determined precisely, and/or the supplier of the material needs to be consulted.

The following applies to drilling operations with a double-bladed tool:

$$f = \frac{f_n}{2}$$

Workpiece materials		Specific cutting forces	Specific cutting forces	Specific cutting forces
Designation	DIN [ISO]	$k_c \left[ \frac{N}{mm^2} \right]$ at $f = 0.1mm^*$	$k_c \left[ \frac{N}{mm^2} \right]$ at $f = 0.5mm^*$	$k_c \left[ \frac{N}{mm^2} \right]$ at $f = 1.0mm^*$
Cast iron	For example EN-GJL-250	1980	1260	900
Spherulitic graphite iron [unhardened]	For example EN-GJS-400-15	2120	1190	1060
construction steels without alloys or with only a low alloy content [of average strength] / cementation steels [unhardened]	For example S235JR [1.0037] S275JR [1.0044] Ck10 [1.1121] 16MnCr5 [1.7131] 18CrNi8[1.5920]	2920	1840	1500

Workpiece materials		Specific cutting forces	Specific cutting forces	Specific cutting forces
Designation	DIN [ISO]	$k_c \left[ \frac{N}{mm^2} \right]$ at $f = 0.1mm^*$	$k_c \left[ \frac{N}{mm^2} \right]$ at $f = 0.5mm^*$	$k_c \left[ \frac{N}{mm^2} \right]$ at $f = 1.0mm^*$
construction steels without alloys or with only a low alloy content [unhardened, with higher strength]	S355J2G3 [1.0570] E360 [1.0070]	3350	2000	1600
Tempered steels [pre-annealed]	C45 [1.0503] C60 [1.0601] 42CrMo4 [1.7225] 34CrNiMo6 [1.6582]	2850	1960	1660
tool steels without alloys or with only a low alloy content [unhardened]	C105W1 [1.1545]	3100	2100	1690
Machining steels	35S20 [1.0726] 60S20 [1.0728]	1700	1480	1400
Stainless steels		3600	2450	2100
Hardened steels		4800		
Aluminum forging alloy <16% Si		1340	900	750
Aluminum casting alloy <16% Si		1520	1000	850
Brass		1300	850	700

\* For feed rates between 0.05 mm and 0.1 mm, use the  $f=0.1$  mm value with a 20% allowance.

\*\* For feed rates between 0.1 mm and 0.5 mm, employ interpolation.

\*\*\* For feed rates between 0.5 mm and 1.0 mm, employ interpolation. For feed rates > 1.0 mm, use gap  $f=1.0$  mm.

Table 9: Specific cutting forces

### Friction coefficients

With workpieces made from a material other than steel, multiply these values by the correction values listed below.

When the workpiece is made of hardened steel, the values for smooth clamping heads always apply to ground workpiece surfaces.



#### NOTE

**Damage to materials caused by using the wrong clamping head when clamping hardened materials!**

- For the clamping of hardened materials, or of high-tensile materials  $R_m > 1300 \left[ \frac{N}{mm^2} \right]$ , the only permitted clamping heads are smooth with longitudinal and transverse serrations!
- Other versions of clamping head may get damaged and lose their ability to achieve higher friction coefficients on soft materials.

	Clamping surface			
	SP WS	SP WS	SP WS	SP WS
Workpiece surface				
	Smooth clamping head	Clamping head with longitudinal and transverse serrations	Clamping head with Z serrations	Clamping head with F serrations
Finished, ground	$\mu_t = 0.06$ $\mu_a = 0.08$	$\mu_t = 0.07$ $\mu_a = 0.09$	$\mu_t = 0.15$ $\mu_a = 0.20$	$\mu_t = 0.17$ $\mu_a = 0.22$
Finished to roughed	$\mu_t = 0.10$ $\mu_a = 0.13$	$\mu_t = 0.11$ $\mu_a = 0.15$	$\mu_t = 0.18$ $\mu_a = 0.25$	$\mu_t = 0.23$ $\mu_a = 0.28$
Blank or unmachined	$\mu_t = 0.14$ $\mu_a = 0.16$	$\mu_t = 0.16$ $\mu_a = 0.18$	$\mu_t = 0.20$ $\mu_a = 0.28$	$\mu_t = 0.25$ $\mu_a = 0.30$
Material correction values	Aluminum alloys = 0.97			
	Brass = 0.92			
	Cast iron = 0.80			

WS Workpiece

SP Clamping element

Table 10: Friction coefficient for steel workpieces



**Clamping head mass  $m[kg]$  and distance of mass center of gravity of clamping head segments to the rotational axis  $r_s[m]$**

Size of clamping head	Distance to mass center of gravity $r_s[m]$ in smallest position	Clamping head mass $m[kg]$
32	0.015	0.55
42	0.021	0.70
52	0.022	1.00
65	0.027	2.20
80	0.032	2.70
100	0.045	3.60
125	0.061	9.10
140	0.062	9.10
160	0.075	12.20

Table 11: Clamping head mass and distance of mass center of gravity of clamping head segments to the rotational axis

### Determining the required clamping force



#### INFORMATION

$S$  from Table 6

$c$  from Table 8

$k_c$  from Table 9

$\mu_a, \mu_t$  from Table 10

$r_s, m$  from Table 11

I

$$F_{rad\ erf} = S * c * (1.6 * (F_{sz} + F_{sk}) + F_{fz})$$



#### INFORMATION

Factor 1.6 takes account of possible fluctuations that may occur during power transmission.

II

$$F_{SZ} = 1.3 * \sqrt{\left(\frac{F_c * d_z + 2 * M_B}{d_{sp} * \mu_t}\right)^2 + \left(\frac{F_c + F_B}{\mu_a}\right)^2}$$

Turning [inner and outer]

$$F_c = 1.3 * a_p * f * k_c$$

Drilling [drilling solid materials, double-bladed tool, concentrically towards the workpiece axis]

$$F_B = 0.45 * D_B * f_n * k_c$$

$$M_B = \frac{f_n * D_B^2 * k_c}{5700}$$



### INFORMATION

When calculating machining forces, a level of tool blunting is built in, corresponding to a wear mark width of 0.3mm.

III

$$F_{sk} = \frac{\left(0.27 * \frac{L_z}{d_{sp}} + 0.63\right) * \sqrt{\left(F_c * L_z + F_G * L_g\right)^2 + \left(F_c * P\right)^2}}{0.5 * \left(0.67 * \left(1.9 * L_{sp} - 4.5mm\right) + \mu_a * d_{sp}\right)}$$

Longitudinal turning  $P = \frac{d_z}{2}$

Surface turning / plunge-machining  $P = L_z$

If the workpiece is braced against a tailstock, it is OK to continue calculating with 20% from the computed  $F_{sk}$  value.

IV

$$F_{fz} = m * r_s * \left(\frac{\pi * n}{30}\right)^2$$

With reference to the principle defined at the start, this means that the radial clamping force of the clamping head chuck equates to at least the computed level of radial clamping force required  $F_{rad\ erf}$  to resolve this use of the clamping head chuck.

If this condition is not satisfied, the clamping head chuck would not be suitable. It would not then be possible to perform this machining task.

When clamping and machining workpieces with bigger errors in axial and face run-out, please note that the cutting cross-section fluctuates greatly. Particular attention needs to be paid to the resultant local increase in cutting force.

### Determining the required clamping force for radial drilling operations

With radial drilling operations directed at the center, radial clamping force  $F_{rad\ erf}$  is also determined in accordance with an approach

$$F_{rad\ erf} = S * c * \left(1.6 * \left(F_{SZ} + F_{sk}\right) + F_{fz}\right)$$

whereby, although based upon components  $F_{sz} = 0$  and  $F_{fz} = 0$ , a simplified form [just transverse force] can be used:

$$F_{rad\ erf} = S * c * 1.6 * F_{sk}$$

Determining of  $F_{sk}$  can be calculated as follows for drilling operations performed radially in relation to the clamping device axis, in a similar way to Formula III:

$$F_{sk} = \frac{\left(0.27 \cdot \frac{L_z}{d_{sp}} + 0.63\right) * (F_q * L_z + F_G * L_g)}{0.5 * (0.67 * (1.9 * L_{sp} - 4.5mm) + \mu_a * d_{sp})}$$

To calculate  $F_q$ , see the »Further to Principle 4:  $F_q \leq F_{q\ max}$ « chapter.

$$F_q = F_B = 0.45 * D_B * f_n * k_c$$

### 5.2.5.2 Further to Principle 2: $F_t \leq F_{t\ max}$

When using a tailstock, due to the additional expanding force exerted on the clamping head chuck, the permitted maximum tailstock force is limited to the following values in accordance with the size of the clamping head chuck:

Size of the clamping head chuck	$F_{t\ max}[kN]$
32	3
42	6
52	6
65	8
80	8
100	8
125	8
140	8
160	8

Table 12: Maximum permitted tailstock force



#### NOTE

**Serious damage to materials on clamping equipment and machine tool due to non-adapted forces!**

- The total of set tailstock force and axial clamping force during the clamping process must be exceeded by the release force.

When operating with a tailstock, using an end-stop in the clamping head chuck ensures that the workpiece is not displaced axially.

### 5.2.5.3 Further to Principle 3: $F_c \leq F_{c\ max}$

The cutting force for turning operations can achieve very high levels, especially if the workpiece does not protrude far, although machining involves no slip or leverage forces that could displace the workpiece. Therefore the cutting force also needs to be limited to reflect the size of the clamping head chuck to prevent damage to the clamping head chuck.

Size of the clamping head chuck	Up to total chuck length $L[mm]$	$F_{c\ max}[N]$
32	< 120	1900
42	< 125	3600
52	< 125	3600
65	< 140	5000
80	< 140	6000
100	< 160	8000
125	< 200	12000
140	< 200	12500
160	< 200	14000

Table 13: Maximum permitted cutting force

On extended chuck versions, the ratio of maximum permitted cutting force to chuck lengths needs to be reduced. For example, size 32 with  $L = 150mm$

$$\frac{120mm}{150mm} * 1900N = 1520N$$

### 5.2.5.4 Further to Principle 4: $F_q \leq F_{q\ max}$

With drilling operations radial to the workpiece axis, the feed force of the tool generates transverse forces that ultimately act on the clamping head chuck. The application of this load during drilling operations should be viewed as equivalent to the cutting force exerted by a turning process. Accordingly, it also has to be limited. Consult the following table for the permitted maximum values.

Feed force occurring while drilling  $F_B$  [transverse force]  
[drilling of solid materials, double-bladed tool, direction of machining at an angle of  $90^\circ$  to the chuck axis]

$$F_q = F_B = 0.45 * D_B * f_n * k_c$$



#### INFORMATION

$k_c$  from Table 9

Size of the clamping head chuck	Up to total chuck length $L$ [mm]	$F_{q\ max}$ [N]
32	< 120	2200
42	< 125	4200
52	< 125	4200
65	< 140	6000
80	< 140	7200
100	< 160	9000
125	< 200	13000
140	< 200	13800
160	< 200	15000

Table 14: Maximum permitted transverse force

On extended chuck versions, the ratio of maximum permitted transverse force to chuck lengths needs to be reduced. For example, size 32 with  $L = 150\text{mm}$

$$\frac{120\text{mm}}{150\text{mm}} * 2200\text{N} = 1760\text{N}$$

#### 5.2.5.5 Further to Principle 5: $M_q \leq M_{q\ max}$

With drilling operations that are radial to the workpiece axis, the transverse force examined under Principle 4 exerts an additional torque  $M_q$  on the clamping head and/or on the chuck. This moment must not rise in an unlimited way to prevent damage to the clamping head chuck, even if the clamping of the workpiece may still hold firmly. The following table shows the related permissible maximum values.

Torque  $M_q$  occurring through the introduction of transverse force  $F_q$

$$M_q = F_q * L_q$$

Size of the clamping head chuck	Up to total chuck length $L$ [mm]	$M_{q\ max}$ [Nm]
32	< 120	120
42	< 125	210
52	< 125	210
65	< 140	300
80	< 140	360

Size of the clamping head chuck	Up to total chuck length $L$ [mm]	$M_{q\ max}$ [Nm]
100	< 160	450
125	< 200	650
140	< 200	690
160	< 200	750

Table 15: Maximum permitted torque due to transverse force

On extended chuck versions, the ratio of maximum permitted torque to chuck lengths needs to be reduced. For example, size 32 with  $L = 150mm$

$$\frac{120mm}{150mm} * 120Nm = 96Nm$$

### 5.2.6 Sample calculation

#### Applied to a specific example

Longitudinal turning of an offset shaft made of 16MnCr5 [blank clamping diameter] unsupported in a horizontal position.

#### Workpiece data

- Clamping diameter  $d_{sp} = 60mm$
- Workpiece length  $L_w = 150mm$  [151.5mm blank]
- Machining diameter of turning operation  $d_z = 57.0mm$
- Workpiece mass  $m_w = 3.3kg$ 
  - $F_G = m_w * 9.81 \frac{m}{s^2}$
  - $F_G = 33N$

#### Process data

- Speed  $n = 800min^{-1}$
- Feed  $f = 0.25mm$
- Chip-cutting depth  $a_p = 1.5mm$
- Use of cooling lubricant
- Total clamping length  $L_{sp\ v} = 20mm$

#### Clamping head chuck

- Pull-back SPANNTOP size 65
- Clamping head used
  - Smooth
  - Clamping diameter of clamping head  $D = 60mm$
  - Front-end length  $L_v = 3mm$

### Detailed observation

This satisfies the first condition, which is that the unclamping length must not exceed six times the clamping diameter.

This also satisfies the second condition, which is that the workpiece mass must not exceed  $m_w$  40kg of size 65 of clamping head chuck.

This more than satisfies the third condition, which is that the workpiece must at least be clamped with  $0.08 * d_{sp} = 0.08 * 60mm = 4.8mm$ , with a clamping length of  $L_{sp} = L_{spv} - L_v = 20mm - 3mm = 17mm$ .

To check the fourth condition, the required level of clamping force needs to be established first, in accordance with Principle 1.



#### INFORMATION

$S$  from Table 6

$c$  from Table 8

$k_c$  from Table 9 [interpolated for  $f = 0.25mm$ ]

$\mu_a, \mu_t$  from Table 10

$r_s, m$  from Table 11

I

$$F_{rad\ erf} = S * c * (1.6 * (F_{sz} + F_{sk}) + F_{fz})$$

from Table 6  $S = 1.6$

from Table 8  $c = 1.3$

$$F_{rad\ erf} = 1.6 * 1.3 * (1.6 * (F_{sz} + F_{sk}) + F_{fz})$$

II

$$F_{SZ} = 1.3 * \sqrt{\left(\frac{F_c * d_z + 2 * M_B}{d_{sp} * \mu_t}\right)^2 + \left(\frac{F_c + F_B}{\mu_a}\right)^2}$$

from Table 10  $\mu_t = 0.14$ ,  $\mu_a = 0.16$

Turning:

$$F_c = 1.3 * a_p * f * k_c$$

$$F_c = 1.3 * 1.5mm * 0.25mm * 2515 \frac{N}{mm^2} = 1226N$$

Drilling:

Not relevant here because no drilling is envisaged. Therefore  $F_B = 0N$  and  $M_B = 0Nmm$

$$F_{SZ} = 1.3 * \sqrt{\left(\frac{1226N * 57mm + 2 * 0Nmm}{60mm * 0.14}\right)^2 + \left(\frac{1226N + 0N}{0.16}\right)^2}$$

$$F_{SZ} = 14703N$$

III

$$F_{Sk} = \frac{\left(0.27 * \frac{L_z}{d_{sp}} + 0.63\right) * \sqrt{(F_c * L_z + F_G * L_g)^2 + (F_c * P)^2}}{0.5 * (0.67 * (1.9 * L_{sp} - 4.5mm) + \mu_a * d_{sp})}$$

$L_z = L_w = 133mm$ , since the shaft should be surface-turned at the front end of the shaft.

$L_g = 75mm$ , since the center of gravity is located centrally on the longitudinal axis of the work-piece.

$L_{sp} = 17mm$ , corresponds to the total clamping length less the front-end length of the clamping head.

$P = \frac{d_z}{2} = \frac{57mm}{2} = 28.5mm$ , because of a longitudinal turning operation

$$F_{Sk} = \frac{\left(0.27 * \frac{133mm}{60mm} + 0.63\right) * \sqrt{(1226N * 133mm + 33N * 75mm)^2 + (1226N * 28.5mm)^2}}{0.5 * (0.67 * (1.9 * 17mm - 4.5mm) + 0.16 * 60mm)}$$

$$F_{Sk} = \frac{207838Nmm}{14.11mm} = 14727N$$

IV

$$F_{fz} = m * r_s * \left(\frac{\pi * n}{30}\right)^2$$

from Table 11:  $m = 2.2kg$ ,  $r_s = 0.027m$

$$F_{fz} = 2,2kg * 0,027m * \left(\frac{\pi * 800min^{-1}}{30}\right)^2$$

$$F_{fz} = 417N$$

$$F_{rad\ erf} = 1.6 * 1.3 * (1.6 * (F_{SZ} + F_{Sk}) + F_{fz})$$

$$F_{rad\ erf} = 1.6 * 1.3 * (1.6 * (14703N + 14727N) + 417N)$$

$$F_{rad\ erf} = 98810N = 99kN$$



Since the size 65 clamping head chuck can exert a maximum radial clamping force of  $F_{rad\ max} = 105kN$ , this satisfies Principle 1.

In this example, Principle 2 does not apply because work is performed without a tailstock in this case.

Principle 3 would also be satisfied, because the calculated cutting force of  $F_c = 1226N$  is well below the limit of  $F_{c\ max} = 5000N$ .

On the other hand, Principles 4 and 5 are immaterial in this example because both principles only need to be considered in relation to radial drilling operations.

### **Result of the sample calculation**

All limits have been checked.

The axial actuation force is proportional to the radial clamping force and interpolation can therefore be used to determine this on the basis of the values for  $F_{ax\ max}$  and  $F_{rad\ max}$ , as indicated on the clamping head chuck, or you can consult the clamping force diagram [see »Clamping force diagram« chapter].

When full axial force is exerted on the clamping head chuck with  $F_{ax\ max} = 45kN$ , nominal radial  $105kN$  forces are being applied to the workpiece.

In the example calculated here, an axial force of at least  $F_{ax} = 43kN$  must be applied, resulting in a radial clamping force of  $F_{rad} = 99kN$ .

This satisfies condition  $F_{rad} \geq F_{rad\ erf}$ .

Machining can then be performed.

The value is close to the limit value. This ensures that the clamping head chuck is in good condition in terms of the level of contamination.

It is advisable to conduct a check on radial clamping force using an appropriate clamping force meter before the machining operation. The values established must lie within an appropriate range for the rotational speed [see »Clamping force diagram« chapter].

## 6 Transport, packaging, storage

### 6.1 Safety, transport, packaging, storage



#### **WARNING**

**High level of physical strain due to the weight of the product or of its components if not transported properly!**

- From a weight of 10 kg, use appropriate transport equipment, lifting gear and lifting tackle.



#### **WARNING**

**Serious crushing injuries and breakages caused by falling parts if transported incorrectly!**

- Ensure that the product cannot roll away or fall.
- Place on a non-slip surface.
- When using lifting gear, use appropriate load-bearing equipment and lifting tackle.



#### **WARNING**

**Serious injuries caused by transporting off-center equipment!**

- Pay attention to marks on the packaging items.
- Attach the crane hook directly above the center of gravity.
- Raise carefully and correct the lifting points if necessary.



#### **WARNING**

**Serious injuries caused by incorrect transport with lifting gear!**

- Never raise loads above people.
- Never step under suspended loads.
- Pay attention to information about the intended lifting points. Ensure that the lifting gear is mounted on a secure base.
- Only use authorized and undamaged lifting gear, load-bearing equipment and lifting tackle.
- Never exceed the maximum load-bearing capacity of lifting gear, load-bearing equipment and lifting tackle.



#### NOTE

**Damage to materials caused by falling parts if transported incorrectly!**

- Ensure that the product cannot roll away or fall.
- Place on a non-slip surface.
- When using lifting gear, use appropriate load-bearing equipment and lifting tackle.

## 6.2 Symbols on the packaging



### Fragile

Designates packaging items with fragile or breakable contents.

Handle the packaging item with care. Do not drop it and protect it against collision impacts.



### Keep it dry

Keep packaging items dry and protect them from the ingress of water.



### Position designation

Points to the correct upright position of the packaging item.

## 6.3 Transport inspection

Check the delivery on receipt immediately to ensure it is complete and has not been damaged in transit.

Proceed as follows if you find any externally visible signs of damage while in transit:

- Refuse to accept the delivery, or only subject to later approval
- Make a note of the extent of damage on the transportation documents or on the delivery note of the transportation company
- Initiate a complaint



#### INFORMATION

Raise a complaint for every defect as soon as it is discovered. Compensation claims can only be enforced during the applicable complaint periods.

## 6.4 Unpacking and internal transportation

The total weight of the product depends on its size.

Depending on the weight involved, it may be necessary to use lifting gear to lift the product or its components out of the packaging safely, to transport them and to position and install them in the machine tool or on the machine table.

1. The product is packaged in a stable position, and it has threads / bores for transportation.
2. Lifting tackle can be installed in these transportation threads / bores. To lift the product out of its packaging, the front-end functional threads can if necessary be used to attach lifting tackle to upright packaged products.
3. Attach load-bearing equipment to the lifting tackle.
4. Subject to weight, use lifting gear to lift the product out of its packaging safely, and place it down on a stable, flat surface.
5. Secure the product to prevent it from rolling away.
6. When transporting on a trolley or car, ensure that the product is securely mounted on a non-slip surface before starting to move it.

## 6.5 Packaging

The individual packaging items are packaged in an appropriate manner for the type of transportation involved. Always use environmentally compatible materials for packaging purposes.

Packaging should protect individual components from damage in transit, corrosion and other forms of damage, up until installation. For this reason, do not destroy the packaging, and do not remove it until shortly before installation.



### INFORMATION

The packaging units are packaged, wrapped in airtight film and placed in cardboard boxes. On the individual weights of each of the sizes [see »General information« chapter].

Dispose of packaging material in accordance with applicable legislative provisions and local regulations.



### NOTE

#### **Damage to the environment caused by improper disposal of packaging materials!**

- Dispose of packaging materials in an environmentally responsible manner.
- Pay attention to local disposal regulations and, if necessary, appoint a specialist waste disposal company with this work.

### 6.6 Storage



#### INFORMATION

The packaged items may display information relating to storage and readmission to storage that extend beyond the scope of these requirements. Pay attention to these notices.

Store packaged items under the following conditions:

- Safe for storage.
- Do not store outdoors.
- Store in a dry, dust-free place.
- Avoid exposure to aggressive media.
- Protect against direct sunlight.
- Avoid mechanical vibration.
- Storage temperature: 15 to 35°C.
- Relative humidity: Maximum 60%.
- In the event of storage for more than 3 months:
  - On a regular basis, check the general condition of all parts and packaging.
  - If necessary, refresh the preservation or replace it.

### 6.7 Preservation

1. Clean and lubricate the product [see »Cleaning« and »Lubricating the product« chapters].
2. Apply a light coating of preserving oil to the inner and outer faces of the product. Wipe away surplus preserving oil with a soft, lint-free, tear-resistant cloth.
3. Pack product air-tight in foil.
4. Return product to storage [see »Return to storage« chapter].

### 6.8 Return to storage

Return product to storage under the following conditions:

1. Preserve the product [see »Preservation« chapter].
2. The product must be stored in a safe condition. Use an appropriate container for the product, on a non-slip surface, or fit the floor of the shelving unit with an all-round safety border.
3. For storage conditions, see the »Storage« chapter.

## 7 Installation

### 7.1 Installation safety



#### WARNING

**Serious injuries caused by unskilled staff during installation / removal!**

- Installation and removal must be performed by skilled staff from the relevant specialist field.



#### WARNING

**Serious injuries can be caused if the machine tool starts up accidentally!**

- Set the machine tool into set-up mode.
- Remove all tools, auxiliary equipment and items of test equipment immediately from the working area of the machine.
- Remove all lifting gear from the product and from the working area of the machine.



#### WARNING

**Serious injuries caused by the escape of media under high pressure!**

- Shut down media delivery during installation and removal.
- Relieve any pressure trapped in the system.
- Shut down the system.



#### WARNING

**Serious crushing injuries and breakages caused by falling parts during incorrect installation or removal!**

- Ensure that the product cannot roll away or fall.
- If necessary, use an appropriate mounting aid for installation or removal on a vertically suspended machine spindle.



#### WARNING

**Serious crushing injuries caused by improper machine movement during installation or removal!**

- Machine movements are only permitted in set-up mode during installation and removal.
- Never reach into a gap.
- Pay attention to the gap dimensions of moving parts.



## WARNING

**Serious head injuries caused by bending into the working area of the machine!**

- Only ever bend into the working area of the machine if there are no cutting tools or sharp objects in it, or if these are covered.
- Never move body parts under parts in the working area of the machine with the potential to drop down.
- Depending on weight, use an appropriate mounting aid for installation or installing on a vertically suspended machine spindle.



## WARNING

**High level of physical strain due to the weight of the product or of its components if not transported properly!**

- From a weight of 10 kg, use appropriate transport equipment, lifting gear and lifting tackle.



## CAUTION

**Serious cut injuries caused by sharp-edged changing parts and/or clamping elements!**

- All installation / removal of changing parts and clamping elements must be performed by skilled staff from the relevant specialist field.



## NOTE

**Damage to materials caused by lifting gear left in the product!**

- Always remove lifting gear immediately after installing the product.



## NOTE [only for aluminum components]

**Damage to materials can be caused by incorrect screw tightening torques on aluminum components!**

- Pay attention to the reduced screw tightening torques for aluminum components [see »Screw tightening torques« chapter].

## 7.2 Preliminary remarks

- In accordance with their thread size and strength class, screws must be tightened crosswise to the specified tightening torque [see »Screw tightening torques« chapter]. When tightening the screws, do so evenly to prevent any distortion under load.

- To avoid precision errors, clean all screw-fitting points and mating surfaces [Notes on cleaning, see »Cleaning« chapter]. Factory wetting of flat surfaces and, where necessary of clamping elements, only serves as a corrosion inhibitor. This is not functionally related lubrication.
- Only apply lubricant to the mechanical mating surfaces. Pay attention to notes about lubricants [see »Use of lubricants« chapter].
- Avoid too much lubricant on the locating face because this can cause face run-out errors.
- Apply grease to the sealing elements [for example O-rings, rectangular rings] and sealing surfaces. Pay attention to notes about greases [see »Use of lubricants« chapter].
- Do not damage the functional surfaces [flat, mating, tapered and sealing surfaces].

### 7.3 Screw tightening torques

The tables show the specified values.

Knowledge of the applicable guidelines and design criteria is essential.



#### NOTE

#### Damage to materials caused by defective screw tightening torques!

- To secure the product to the machine, pay attention to the values specified by HAINBUCH and by the machine manufacturer for screw tightening torques. If the machine manufacturer stipulates different values, you must consult HAINBUCH.

#### Metric control threads

The following table contains the guide values in Nm for screw tightening torques for achieving the highest permitted pre-load for metric control threads.

- Total friction coefficient  $\mu_{ges} = 0.12$

Thread designation	Tightening torque at screw quality [Nm]	
	10.9	12.9
M4	4	5
M5	7	9
M6	12	15
M8	25	38



Thread designation	Tightening torque at screw quality [Nm]	
	10.9	12.9
M10	50	70
M12	100	130
M16	220	300
M20	400	550
M24	600	800

Table 16: Screw tightening torques, metric control threads

### Aluminum components

The following table contains the reduced screw tightening torques for securing aluminum components.

Thread designation	Tightening torque [Nm]	Minimum screw depth [mm]
M6	10	12
M8	23	16
M10	46	20

Table 17: Screw tightening torques for aluminum components

## 7.4 Preparation of the machine for installation

1. Set the machine into set-up mode.
2. Remove cutting tools and/or sharp objects from the working area of the machine, or cover them.

## 7.5 Installation of the product

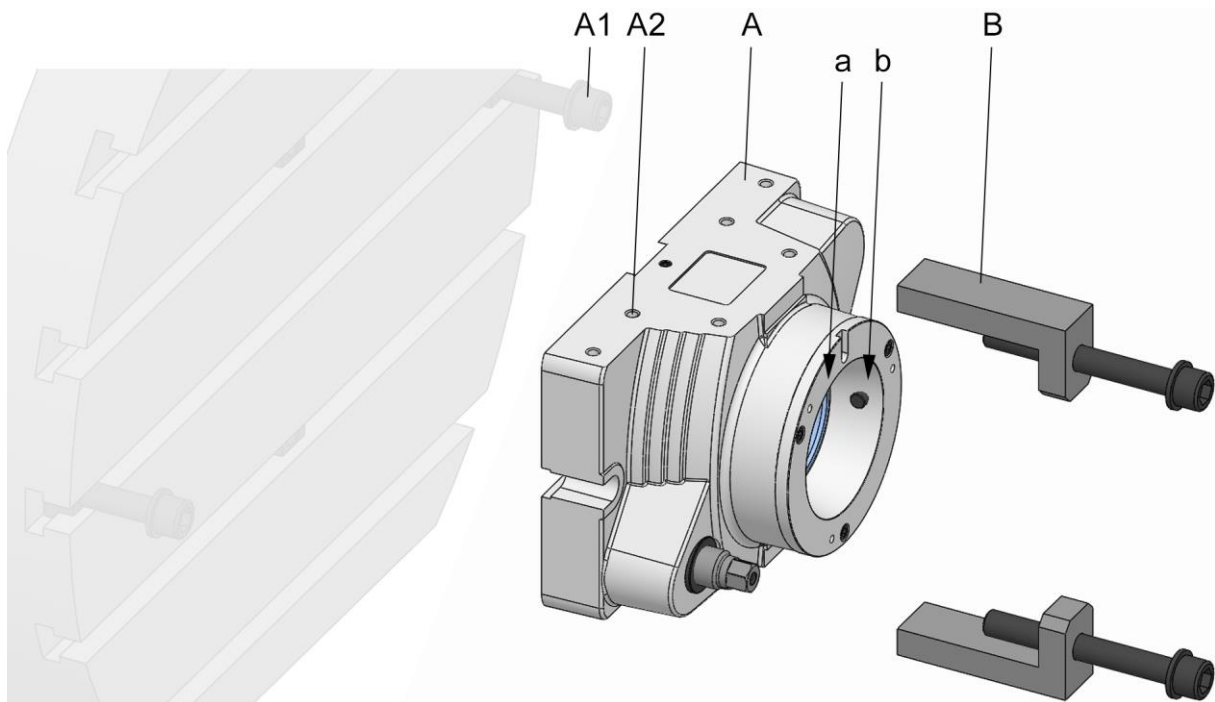

- A Product
- A1 Fixing screws on the product
- A2 Transport thread on product
- B Clamping bracket
- a Test surface, product face run-out
- b Test surface, position product

1. As described in the »Preparation of the machine for installation« chapter, prepare for the following steps.

### 7.5.1 Compatibility check

Check the compatibility of the product and the connection point of the machine.

For this, check that the connection point and the product share the same adaptation geometry. Also check if the actuating element / coupling element is suitable.

It may be necessary to install an adapter between the actuating element on the machine and the product.

### 7.5.2 Preparation of the product

The product is supplied in assembled condition.

No preparatory steps are needed to install the product.

## 7.5.3 Installation of the product on the machine

1. Depressurize the hydraulic unit.
2. Attach any lifting gear that may be required.
3. If necessary, fit the mounting aid onto a vertically suspended spindle.

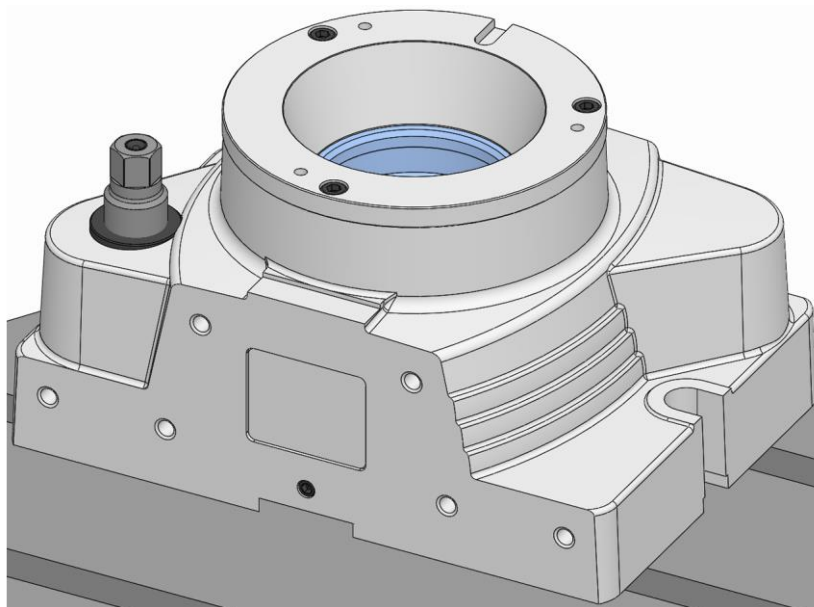

4. Place the product on the machine table.

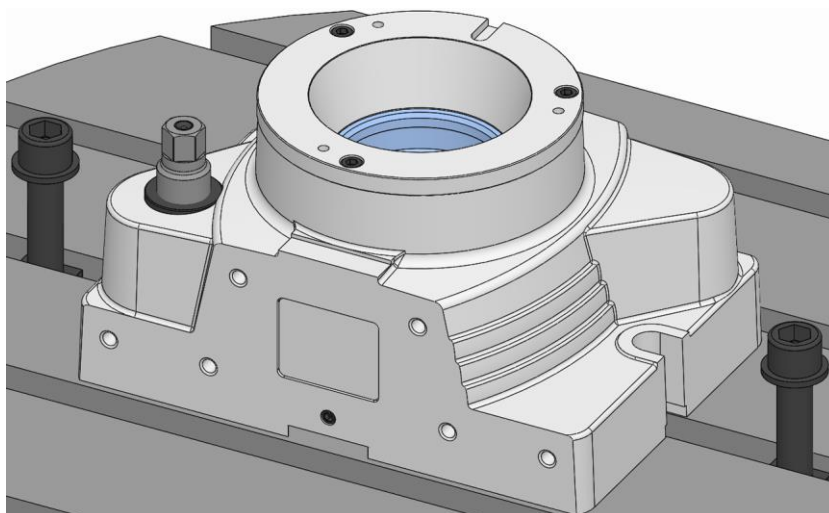

5. Screw in the product fixing screws and tighten them gently.
6. Unfasten and remove any lifting gear that may have been required.
7. Remove the mounting aid on a vertically suspended spindle if one was used.
8. Check the position of the product relative to the position of the test surface [ideally  $\leq 0.01$  mm] and, if necessary, correct carefully with a plastic hammer.

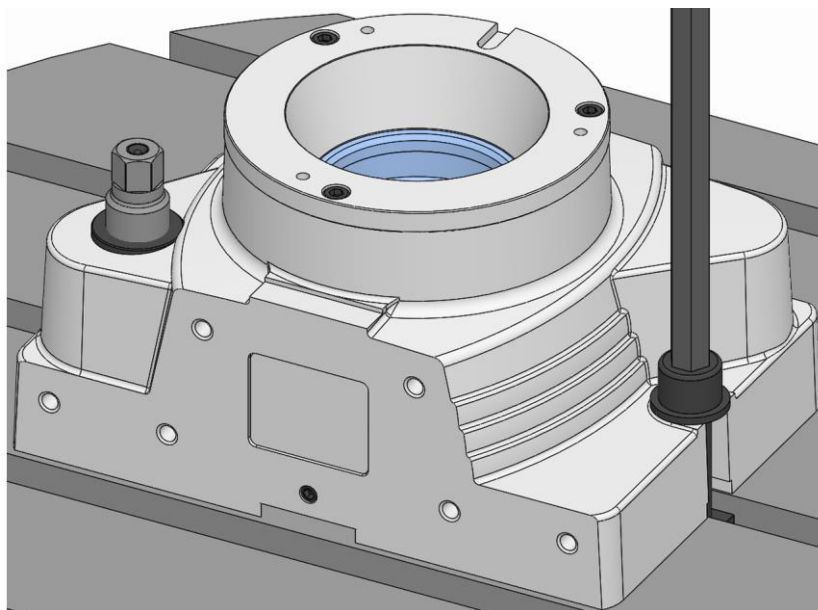

9. Tighten the product fixing screws to the specified tightening torque [see »Screw tightening torques« chapter].

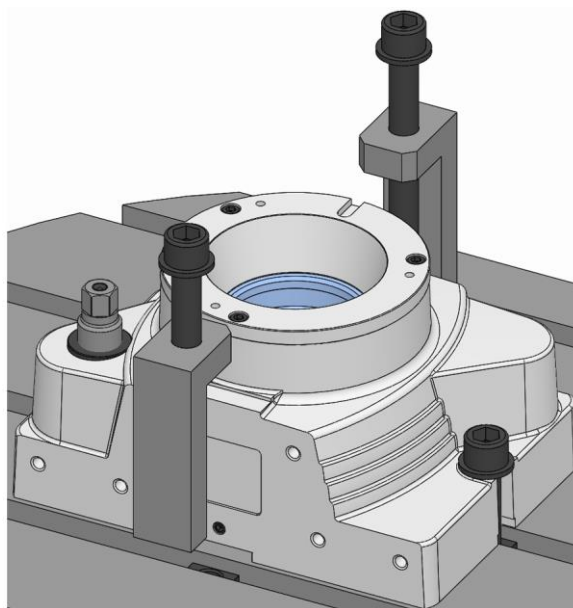

10. Where required, install the clamping brackets needed on the product and the machine table.
11. Check face run-out on the test surface of the product [ideally  $\leq 0.01$  mm].

Whenever the face run-out is greater than the maximum permitted value:

1. Remove the product.
2. Clean the locating face and the mating faces of the machine table and the product.
3. If there is a burr or slight damage to the locating face of the product and the machine table, rub it down gently with an oil stone.
4. Reinstall the product.

5. Repeat the alignment process.
6. Repeat the face run-out test.

## 7.6 Installation of the clamping element

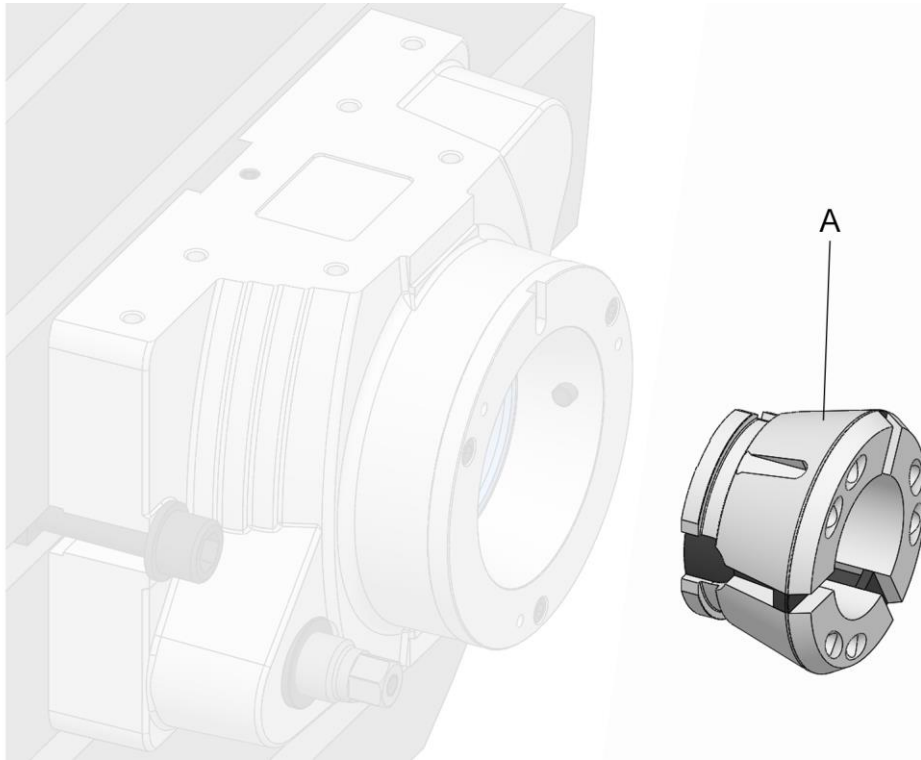

A Clamping head [clamping element]



### INFORMATION

Before installing the clamping element, install the changing part if necessary, otherwise it can no longer be installed.

Special aids needed:

- Changing fixture
1. As described in the »Preparation of the machine for installation« chapter, prepare for the following steps.
  2. Move the clamping device into release position.

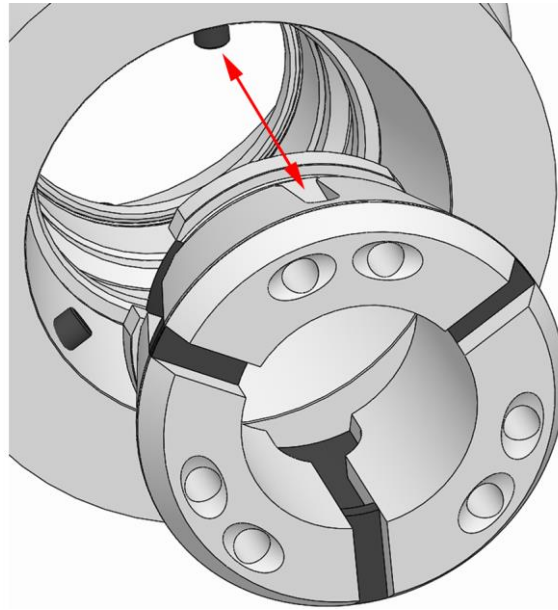

## **WARNING**

**Serious crushing injuries caused by reaching into the coupling / slot area in the clamping head or into the changing fixture!**

- During actuation, never reach into the coupling / slot area in the clamping head or into the changing fixture.

3. Install the clamping head in the product with an appropriate changing fixture. For this the anti-twist devices in the clamping taper of the product and the grooves in the clamping head must be aligned.
4. Unfasten and remove the changing fixture.

## 7.7 Installation of the changing parts

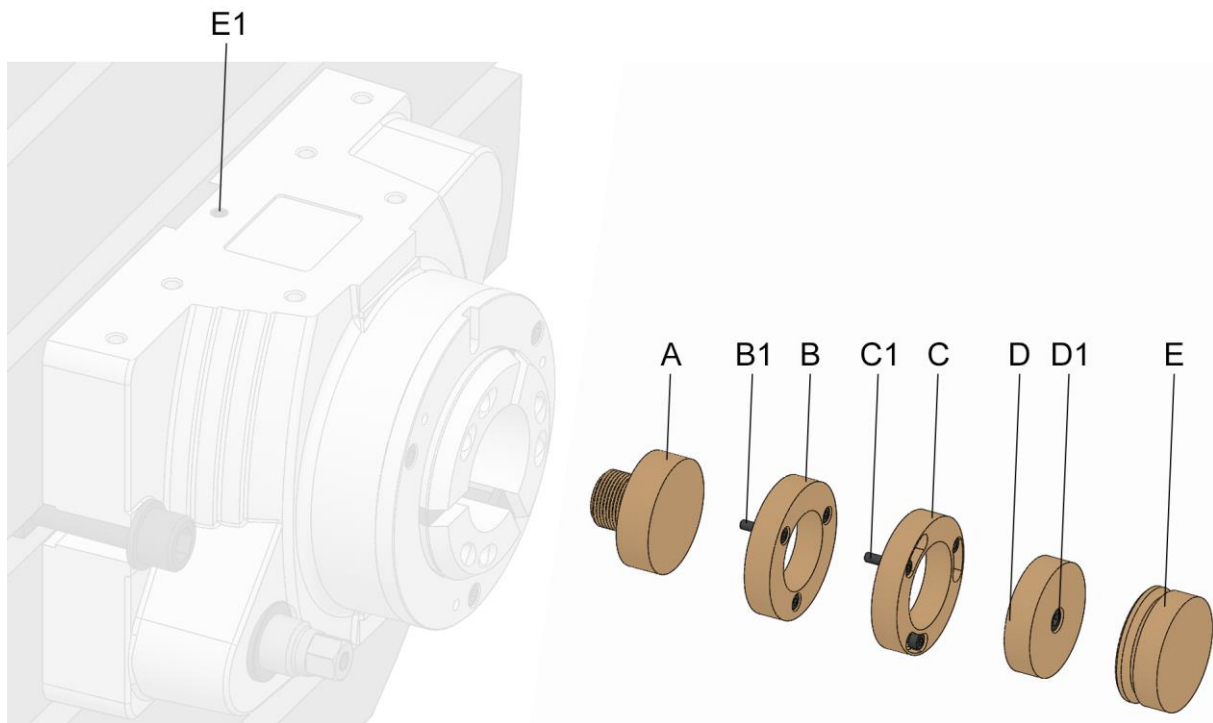

- A Changing part variant direct screw connection
- B Changing part variant x-times axial screw connection
- B1 Fixing screws changing part variant x-times axial screw connection
- C Changing part variant x-times axial screw connection bayonet
- C1 Fixing screws changing part variant x-times axial screw connection bayonet
- D Changing part variant, central, axial screw connection
- D1 Fixing screw changing part variant central axial screw connection
- E Changing part variant radially clamped
- E1 Clamping screw changing part variant radially clamped

The changing parts, such as the workpiece end-stop, can be installed in different ways.



If necessary, in addition to these operating instructions, you should also read and follow the operating instructions for the relevant changing parts.



### INFORMATION

To be able to install the changing part, it may first be necessary to remove the clamping element.

1. As described in the »Preparation of the machine for installation« chapter, prepare for the following steps.
2. Move the clamping device into release position.





## INFORMATION

If necessary, the changing part is positioned. Positioning can for example be performed by marks, or a cylindrical pin and a bore or a groove.

### 7.7.1 Installation of the variant, screwed directly

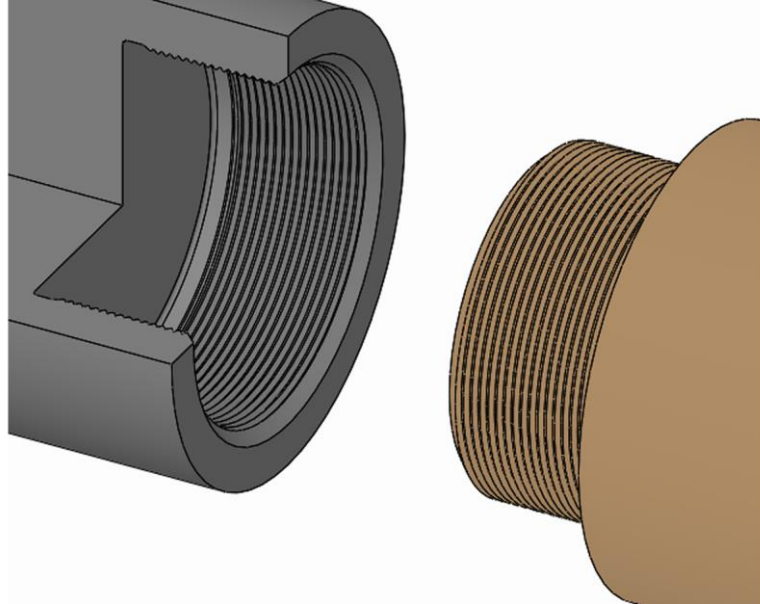

1. Screw the changing part into the product using its thread, and tighten it down.

### 7.7.2 Installation of the variant x-times with axial screw connection

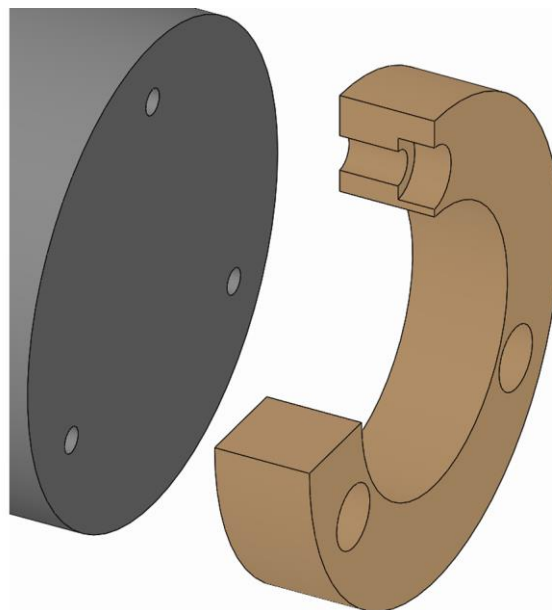

1. Place the changing part onto the product.



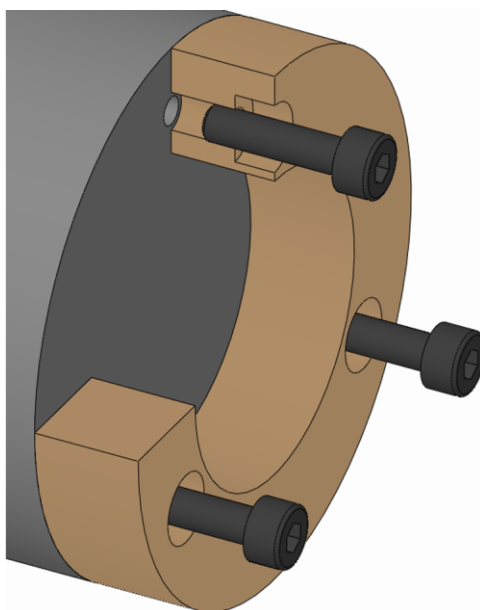

2. Screw in the changing part fixing screws on the changing part and tighten to the specified tightening torque [see »Screw tightening torques« chapter].

### 7.7.3 Installation of the variant x-times with bayonet axial screw connection



#### INFORMATION

Initial installation of the changing part with bayonet is in accordance with the variant with an x-times axial screw connection, see »Installation of x-times variant with axial screw connection«.

After initial installation, the changing part fixing screws remain in the clamping device.

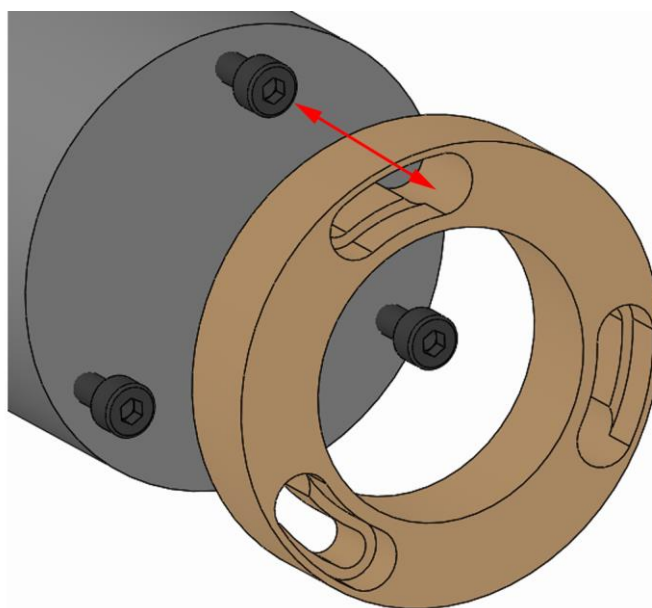

1. Place the changing part on the product so that the screw head on the changing part fixing screw fits through the bayonet opening.

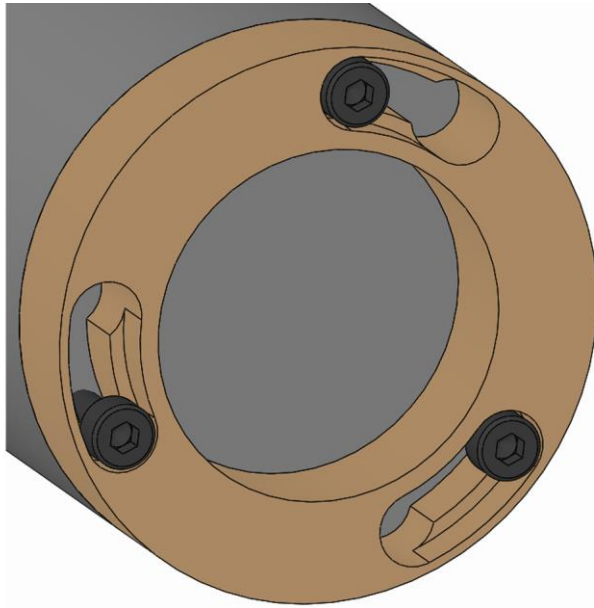

2. Twist the changing part until firmly home.

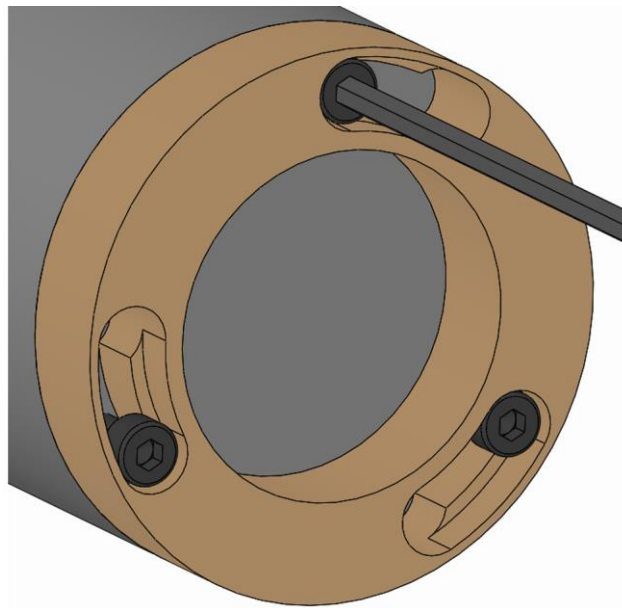

3. Screw in the changing part fixing screws and tighten to the specified tightening torque [see »Screw tightening torques« chapter].

## 7.7.4 Installation of the central variant with axial screw connection

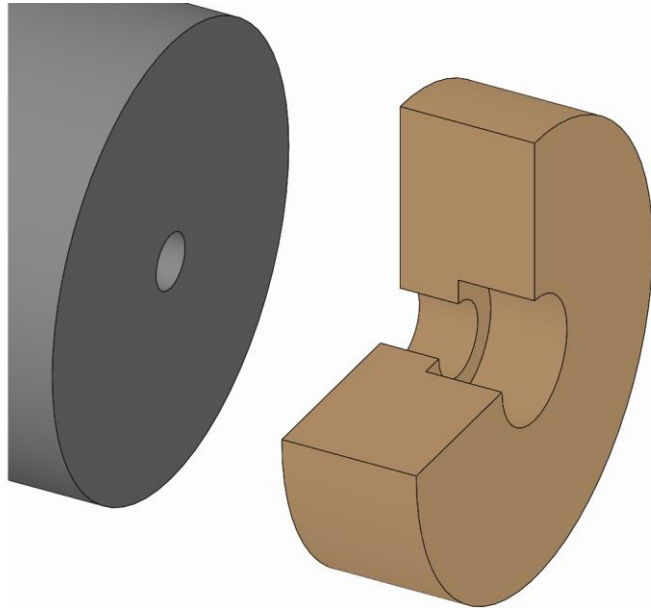

1. Place the changing part into the product.

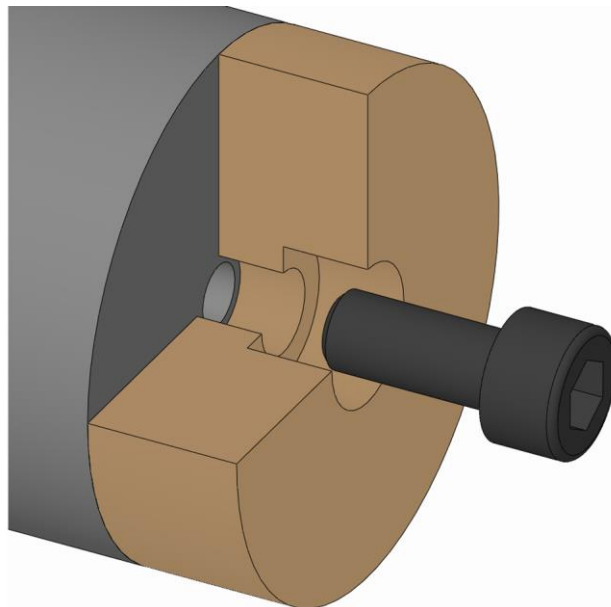

2. Screw in the changing part fixing screw and tighten it to the specified tightening torque [see »Screw tightening torques« chapter].

## 7.7.5 Installation of the radially clamped variant



### INFORMATION

To install / remove the changing part in / from the product, it may be necessary to use a grab handle or an appropriate auxiliary tool.

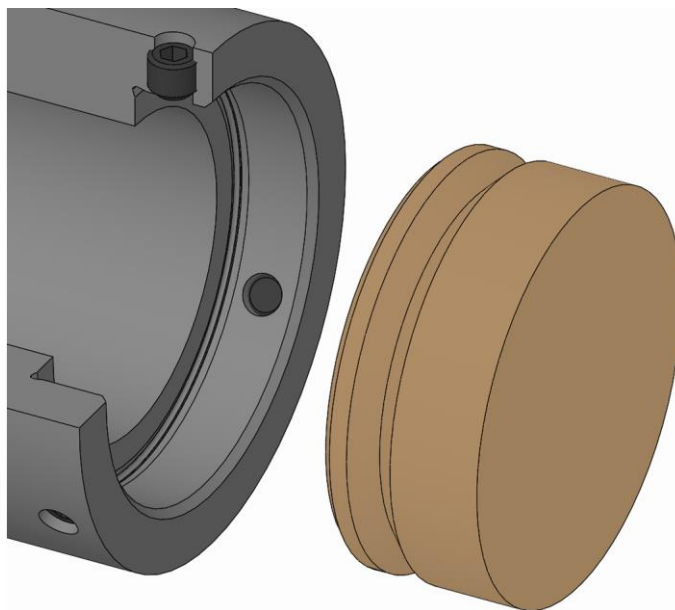

## INFORMATION

When installing the changing part, ensure that it gets installed in the right direction to enable the clamping screw on the radially clamped changing part variant to engage in the groove in the changing part.

When installing the base end-stop, the ground side must face forwards.

1. Place the changing part into the product.

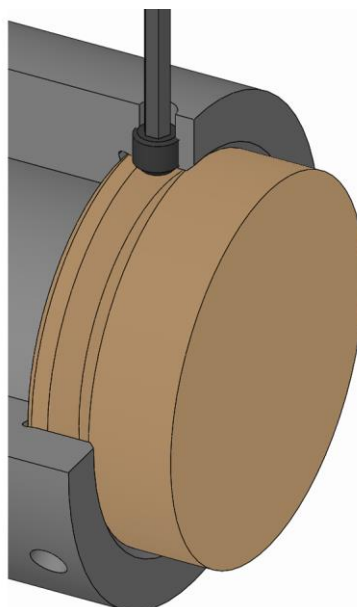

2. Screw in the clamping screws on the changing part and tighten to the specified tightening torque [see Nomenclature].
3. Unfasten and remove the grab handle if used, or the auxiliary tool.

## 7.8 Aligning the clamping device with the test specimen

To achieve the greatest possible accuracy, the clamping device must be aligned on the workpiece. For this, a test specimen can be used. A test specimen can take the form of a test ring, a test shaft or a test workpiece [this is approximated on the workpiece contour].

To align the clamping device using the test specimen, the product fixing screws must be readily accessible.

1. As described in the »Preparation of the machine for installation« chapter, prepare for the following steps.
2. Install the appropriate clamping element for the test specimen and changing part [see »Installation of clamping element« and »Installation of changing parts« chapters].
3. Clamp the test specimen.
4. Unfasten the fixing screws on the product a few turns without removing them.
5. Align the clamping device [see alignment process from the »Installation of the product on the machine« chapter].
6. Ensure that the fixing screws on the product are tightened back down after the alignment process to the specified tightening torque [see »Screw tightening torques« chapter].

## 8 Commissioning

For commissioning purposes, set the operating pressure to the permitted, established machining value.

The machine tool must not start up until full operating pressure has built up.

### 8.1 Commissioning safety



#### DANGER

**Serious injuries caused by workpieces being ejected centrifugally or dropping out if clamping force is insufficient!**

- Workpiece blanks must not be outside the clamping width diameter.
- Prior to commissioning, set the actuation force to the permitted, established machining value.
- Clamping of the workpiece must not be outside the defined limits [see »Limits of use« chapter].
- Check the clamping force at regular intervals and correct if necessary.



#### WARNING

**Serious injuries can be caused if the machine tool starts up accidentally!**

- Prior to commissioning, close all safety doors or hoods on the machine tool.



#### WARNING

**Serious injuries caused by tools and items of test equipment being ejected centrifugally!**

- Prior to commissioning, ensure that all tools and items of test equipment are removed from the working area of the machine.



#### NOTE

**Serious damage to materials / the product caused by workpieces being ejected centrifugally or dropping out if clamping force is insufficient!**

- Workpiece blanks must not be outside the clamping width diameter.
- Prior to commissioning, set the actuation force to the permitted, established machining value.
- Clamping of the workpiece must not be outside the defined limits [see »Limits of use« chapter].
- Check the clamping force at regular intervals and correct if necessary.



## NOTE

### **Damage to components caused by cooling lubricants with sufficient levels of corrosion inhibitor!**

- The components made of steel materials must be protected before the usual oxidation process.
- Only ever use cooling lubricants with sufficient levels of corrosion inhibitor.



## NOTE

### **Damage to materials caused by contaminated / unprocessed cooling lubricants!**

- For the product to function properly, in particular for internal flushing with cooling lubricants and/or when using tools with internal flushing, ensure that the cooling lubricant is cleaned / processed, and that it contains no particles measuring >100 microns [filtered with a mesh width of 100 microns].



## NOTE

### **Damage to seals caused by using the wrong coolant lubricants!**

- To clean the product, never use a cooling lubricant that attacks and damages the sealing elements installed. Those installed sealing elements can be made of NBR, Viton and PUR materials.
- Never use cooling lubricants that contain ester or a polar solvent.



## NOTE

### **Damage to clamping elements caused by using the wrong cooling lubricants!**

- Never use cooling lubricants that contain ester or a polar solvent.

## 8.2 Checking the total stroke



## WARNING

### **Serious crushing injuries caused by moving parts when stroke positions are being tested!**

- Set the machine into set-up mode.
- Never reach into moving parts.
- Pay attention to the gap dimensions of moving parts.

Prior to commissioning, check the complete stroke to ensure that there is sufficient reserve stroke and opening stroke.

For this, the same measurement of the moving part must be performed at fixed points in front and rear limit positions.

Then deduct the value obtained in the rear limit position from the value obtained from the front limit position. This figure must then be equal to or greater than the nominal total stroke.

For the axial nominal total stroke, the values of axial clamping reserve and axial release stroke must be added together [see »General information« chapter].

## 8.3 Tests



### NOTE

**Serious damage to, or destruction of, the machine tool and the workpiece caused by damaged, incomplete or incorrectly installed products!**

- Only install undamaged and complete products properly.
- If in doubt, contact the manufacturer.

Assure the following points before every installation and/or before every time the products are put into service:

- The products used are undamaged.
- All fixing screws are present on the products, and are tightened to the correct tightening torque.
- None of the rubber segments on the clamping elements and attachments are torn or exhibit porous areas.
- Serrations and grooved profiles must not be excessively rounded because this would prevent the friction coefficient from being achieved.
- None of the edges and races are chipped or show any signs of wear.
- The speed set on the machine tool must not exceed the maximum speed of the product [ $n = 0$  on stationary products]. Always take the lowest value of all maximum speeds for combined products indicated.
- Pay attention to the level of actuating force established to enable the workpiece to be clamped with sufficient clamping force.
- Do not exceed the maximum actuating force indicated on the product. Always take the lowest value of all actuating forces indicated for combined products.
- All installation tools are removed from the machining area.
- Clamping device and workpiece are compatible - check clamping diameter on a regular basis.
- Conduct a clamping force measurement.



## 8.4 Workpiece

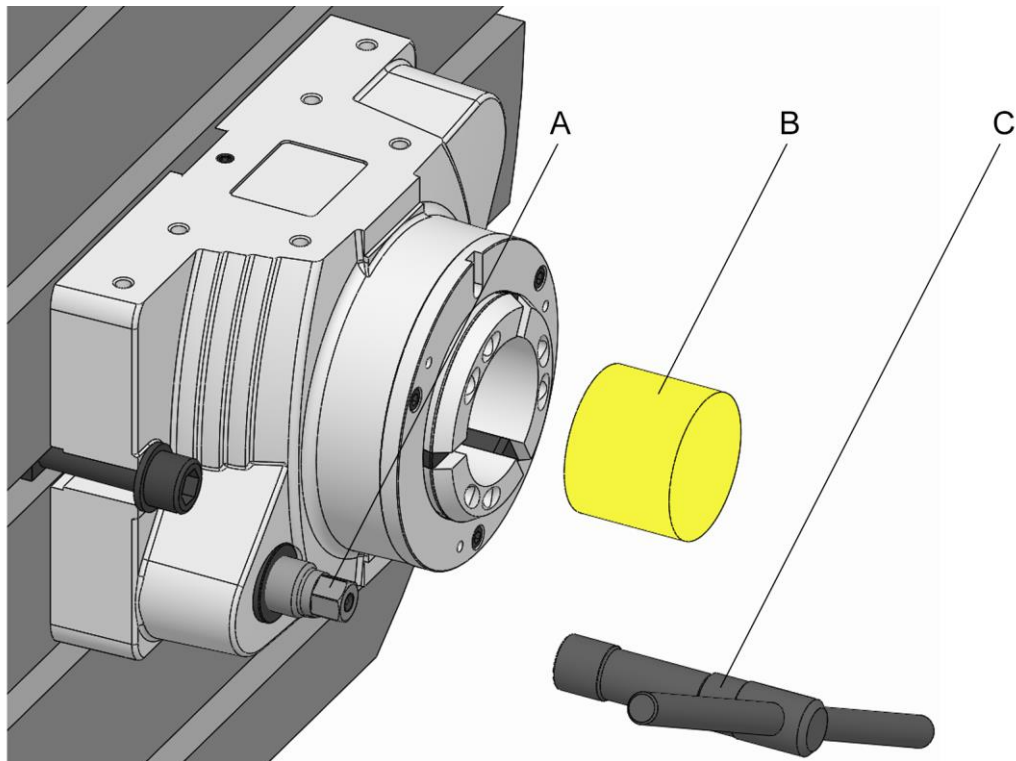

- A Actuating screw
- B Workpiece
- C Actuating key

Special aids required:

- Actuating key



### **DANGER**

**Serious injuries caused by parts being ejected centrifugally if level of workpiece clamping is insufficient!**

- Never utilize the full clamping reserve.
- Do not exceed the permitted maximum clamping reserve stroke.
- The remaining clamping reserve must always be adapted to suit the workpiece material provided and its possible distortions.



### **WARNING**

**Crushing injuries to hands / fingers is workpiece is installed incorrectly!**

- Do not place hands / fingers between workpiece and clamping device.
- Never reach into the clamping area.



## CAUTION

### Burns caused by high workpiece temperature!

- Also wear the following items of personal protective equipment, in addition to the basic equipment:



## WARNING

### Serious injuries caused by projectile ejection of an actuating wrench!

- Only ever use the original actuating wrench!
- Immediately after use, take the actuating wrench out of the product and remove it from the working area of the machine.
- If the self-ejector function of the actuating wrench does not work, or is impaired, it must not be used until after a new spring has been installed.



## INFORMATION

The actuating wrench is equipped with a spring that presses the actuating wrench out of the product as soon as it is released.

### 8.4.1 Clamping the workpiece

To clamp the workpiece, install the appropriate clamping element and/or the appropriate changing parts [see »Installation of the clamping element« and »Installation of changing parts« chapters].

1. Move the clamping device into release position [see »Releasing clamping of the workpiece« chapter].
2. Install the workpiece in the product and, if necessary, secure it to prevent it from falling.

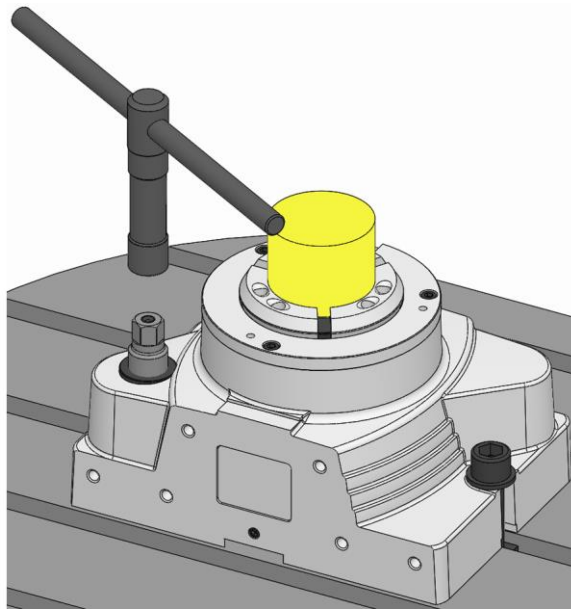

3. Install the actuating key in the actuating screw and hold it firmly.

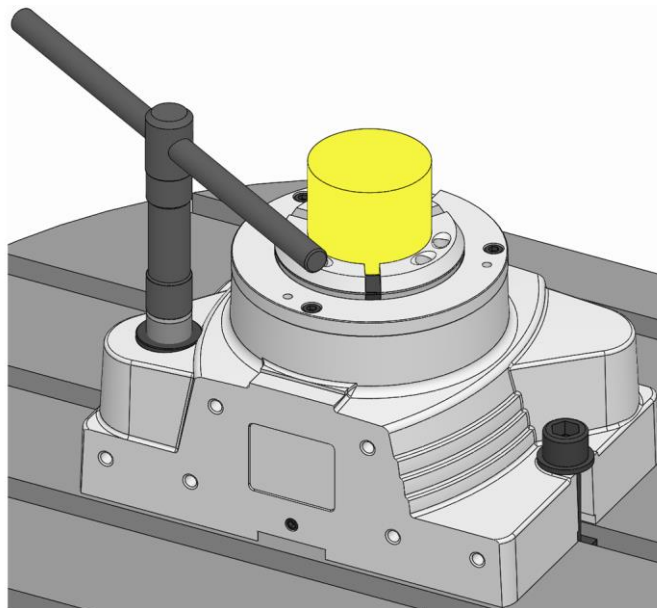

## INFORMATION

To assure uniform tension on the workpiece to tighten the drive, use the torque wrench kit.

4. Turn the actuating screw clockwise with the actuating key and tighten it to the permitted actuation torque determined.

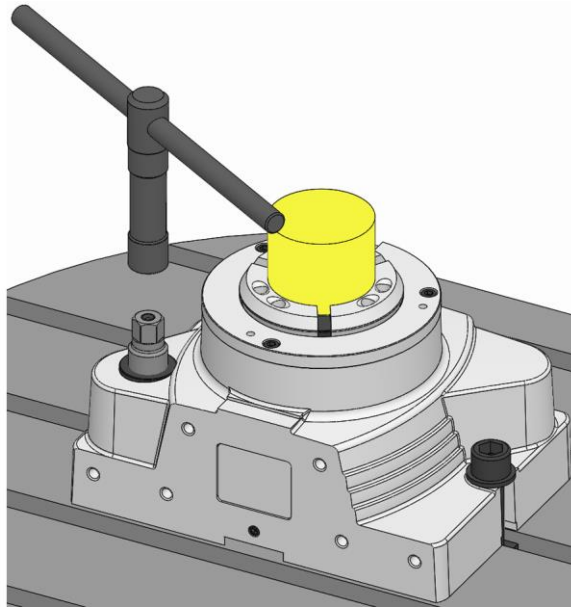

5. Remove the actuating key from the actuating screw and remove it from the working area of the machine.
6. Remove the workpiece mounting if one was used.

## 8.4.2 Releasing tension on the workpiece

1. If necessary, secure the workpiece to prevent it from falling.

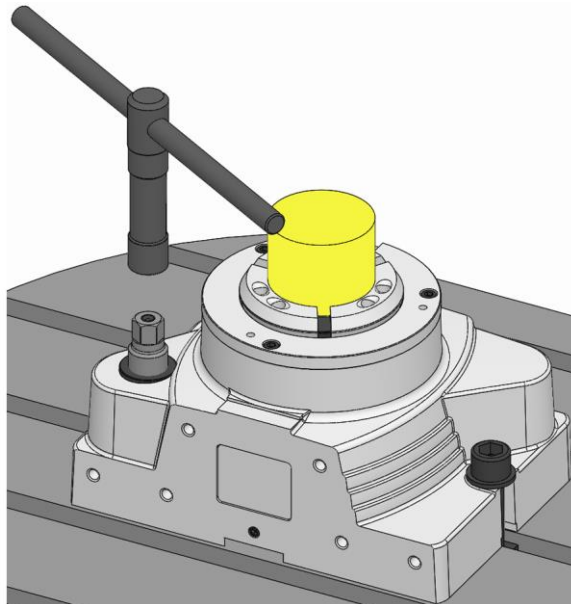

2. Install the actuating key in the actuating screw and hold it firmly.

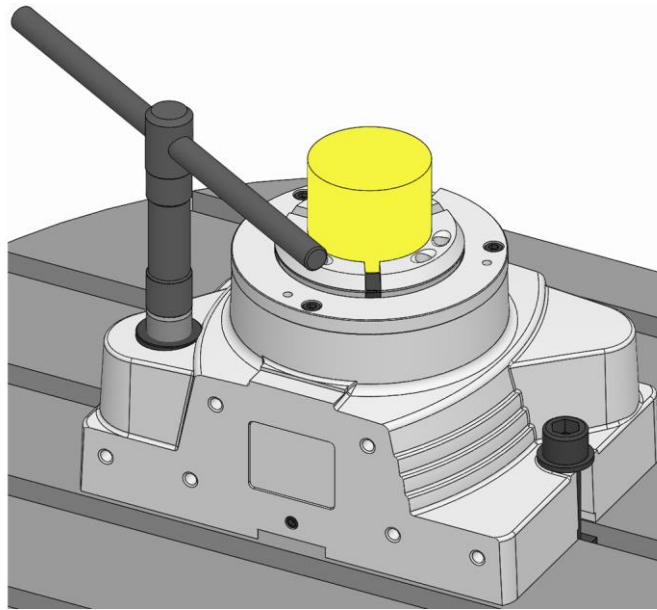

3. Use the actuating key to turn the actuating screw counter-clockwise up to its limit stop.

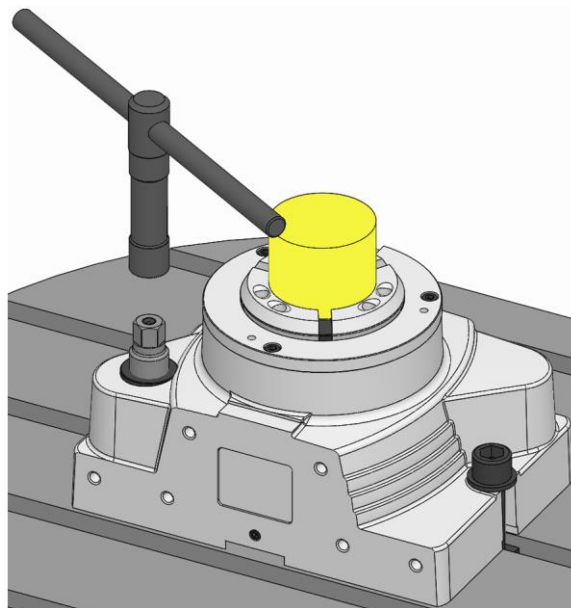

4. Remove the actuating key from the actuating screw and remove it from the working area of the machine.
5. Remove the workpiece from the product. To do this, remove the workpiece mounting if one was used.

## 8.5 Procedure after a collision

In the event of a collision, the product and its components must be checked for cracks and damage before being used again.

For this, remove the product from the machine [see »Removal of the product« chapter] and dismantle it [for level of disassembly, see »Cleaning« chapter].

## 9 Activities after end of production

1. Move product into release position.
2. Switch off machine tool and secure it to prevent it from being switched back on.
3. Open the safety door / hood.



### WARNING

**Eye injuries and cuts caused by failure to wear protective clothing during cleaning operation!**

- Never use compressed air to clean the product.
- Also wear the following items of personal protective equipment, in addition to the basic equipment:



4. Clean the product of swarf and production residue with a soft, lint-free cloth and apply a light coating of oil.
5. Close the safety door / hood.

## 10 Removal

If a break in production occurs that lasts for more than three days, the product must be removed and stored safely in accordance with the manufacturer's stipulations [see »Transport, packaging, storage« chapter].

### 10.1 Safe removal



#### **WARNING**

**Serious injuries caused by unskilled staff during installation / removal!**

- Installation and removal must be performed by skilled staff from the relevant specialist field.



#### **WARNING**

**Serious injuries can be caused if the machine tool starts up accidentally!**

- Set the machine tool into set-up mode.
- Remove all tools, auxiliary equipment and items of test equipment immediately from the working area of the machine.
- Remove all lifting gear from the product and from the working area of the machine.



#### **WARNING**

**Serious injuries caused by the escape of media under high pressure!**

- Shut down media delivery during installation and removal.
- Relieve any pressure trapped in the system.
- Shut down the system.



#### **WARNING**

**Serious crushing injuries and breakages caused by falling parts during incorrect installation or removal!**

- Ensure that the product cannot roll away or fall.
- If necessary, use an appropriate mounting aid for installation or removal on a vertically suspended machine spindle.



## WARNING

### **Serious crushing injuries caused by improper machine movement during installation or removal!**

- Machine movements are only permitted in set-up mode during installation and removal.
- Never reach into a gap.
- Pay attention to the gap dimensions of moving parts.



## WARNING

### **Serious head injuries caused by bending into the working area of the machine!**

- Only ever bend into the working area of the machine if there are no cutting tools or sharp objects in it, or if these are covered.
- Never move body parts under parts in the working area of the machine with the potential to drop down.
- Depending on weight, use an appropriate mounting aid for installation or installing on a vertically suspended machine spindle.



## WARNING

### **High level of physical strain due to the weight of the product or of its components if not transported properly!**

- From a weight of 10 kg, use appropriate transport equipment, lifting gear and lifting tackle.



## CAUTION

### **Serious cut injuries caused by sharp-edged changing parts and/or clamping elements!**

- All installation / removal of changing parts and clamping elements must be performed by skilled staff from the relevant specialist field.



## INFORMATION

If necessary, use any forcing / extraction threads in the components of the product, changing parts or clamping elements.



## 10.2 Preparing the machine for removal

1. Set the machine into set-up mode.
2. Remove cutting tools and/or sharp objects from the working area of the machine, or cover them.
3. Remove operating and auxiliary materials as well as remaining processing materials and dispose of them in an environmentally responsible manner.

## 10.3 Removal of the changing parts

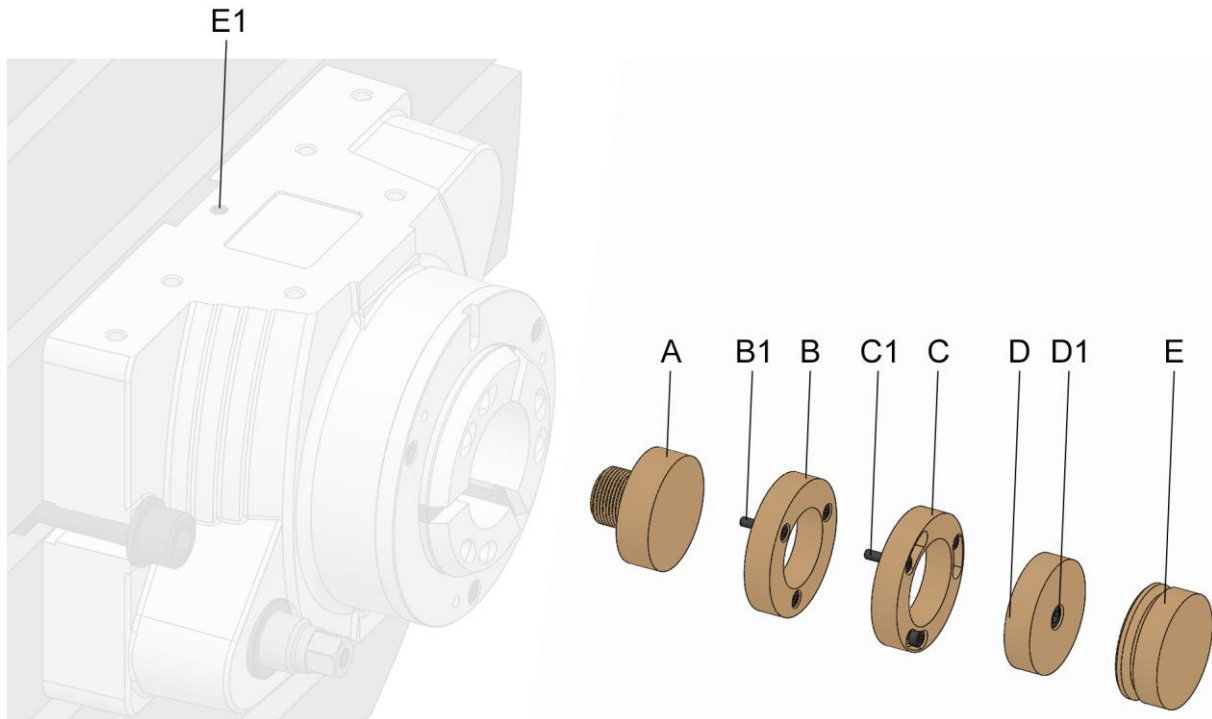

- A Changing part variant direct screw connection
- B Changing part variant x-times axial screw connection
- B1 Fixing screws changing part variant x-times axial screw connection
- C Changing part variant x-times axial screw connection bayonet
- C1 Fixing screws changing part variant x-times axial screw connection bayonet
- D Changing part variant, central, axial screw connection
- D1 Fixing screw changing part variant central axial screw connection
- E Changing part variant radially clamped
- E1 Clamping screw changing part variant radially clamped

Depending on the version of changing parts, they can be removed as follows.



If necessary, in addition to these operating instructions, you should also read and follow the operating instructions for the relevant changing parts.



### INFORMATION

To be able to remove the changing part, it may be necessary to remove the clamping element first.

1. As described in the »Preparing the machine for removal« chapter, prepare for the following steps.
2. Move the clamping device into release position.

## 10.3.1 Removal of the variant with direct screw connection

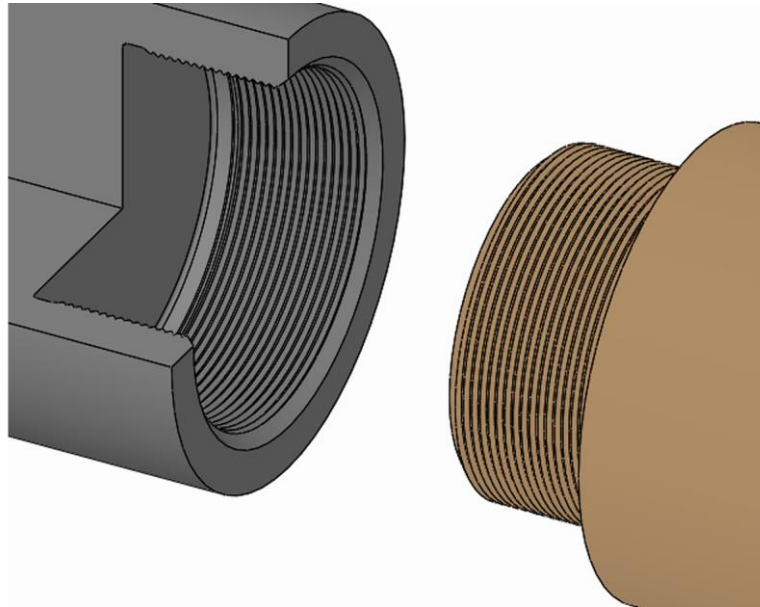

1. Unscrew the changing part from the product using its thread.

## 10.3.2 Removal of the variant x-times with axial screw connection

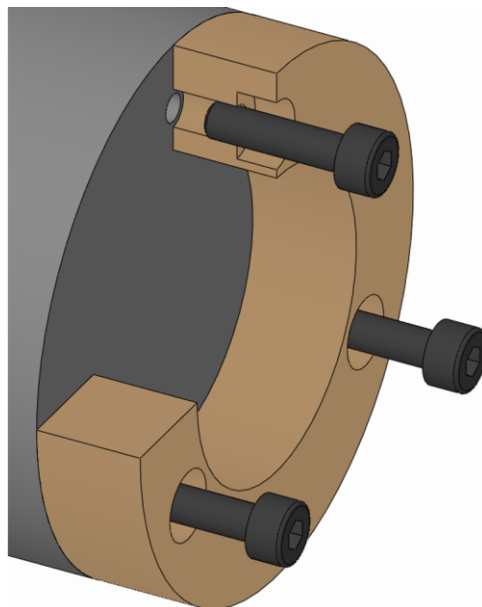

1. Unfasten and remove the fixing screws on the changing part.

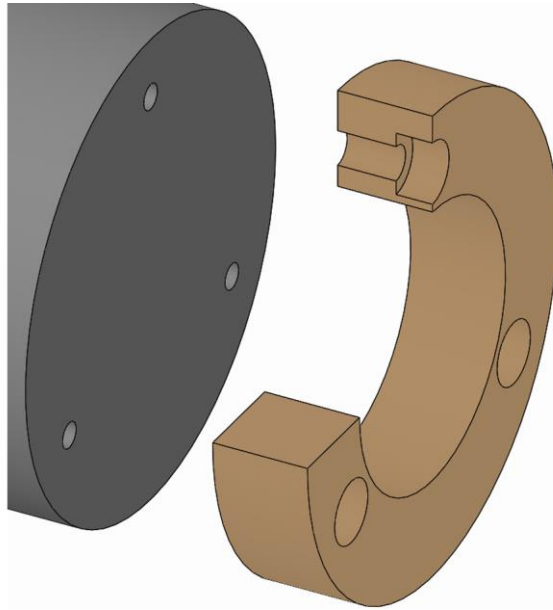

2. Take the changing part off the product.

### 10.3.3 Removal of the variant x-times with axial screw connection bayonet

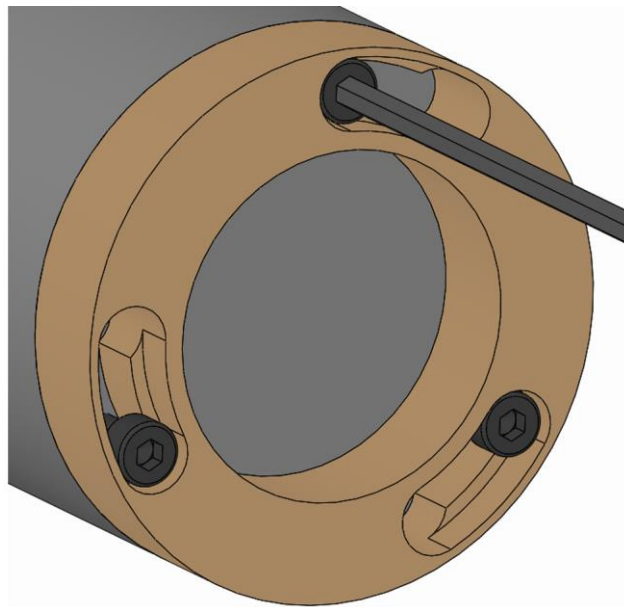

1. Unfasten the fixing screws on the changing body a few turns without removing them.

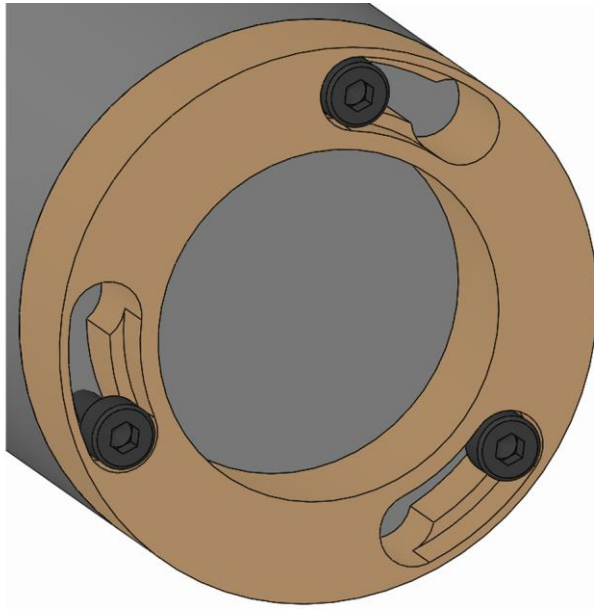

2. Turn the changing part until the screw head on the changing part fixing screw fits through the bayonet opening.

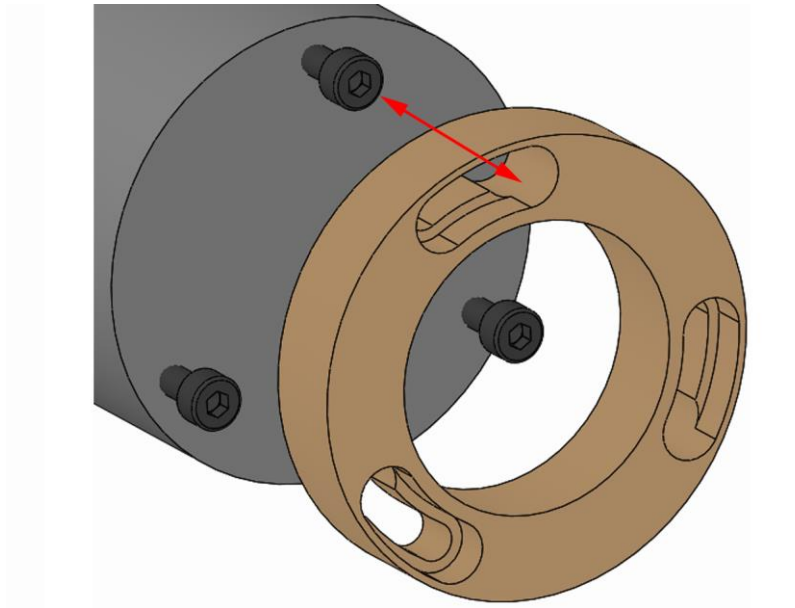

3. Take the changing part off the product.

## 10.3.4 Removal of the central variant with axial screw connection

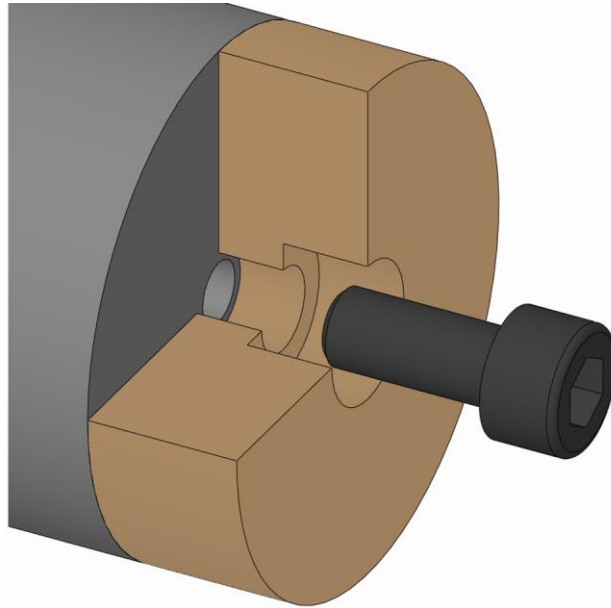

1. Unfasten and remove the fixing screw on the changing part.

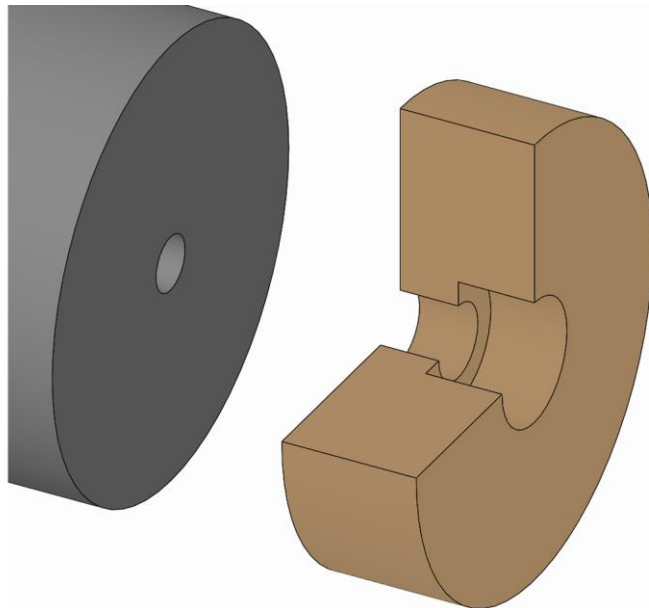

2. Take the changing part out of the product.

## 10.3.5 Removal of the radially clamped variant



### INFORMATION

To install / remove the changing part in / from the product, it may be necessary to use a grab handle or an appropriate auxiliary tool.

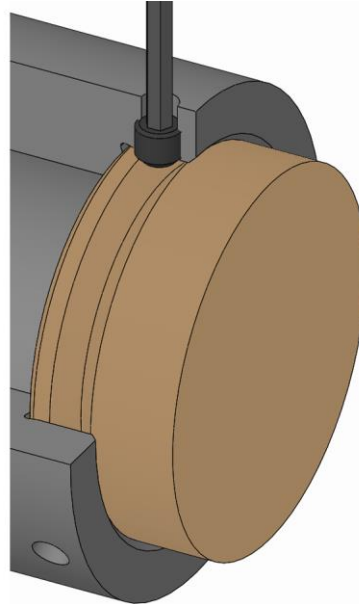

1. Unscrew the clamping screws from the changing part until the changing part can be lifted out.

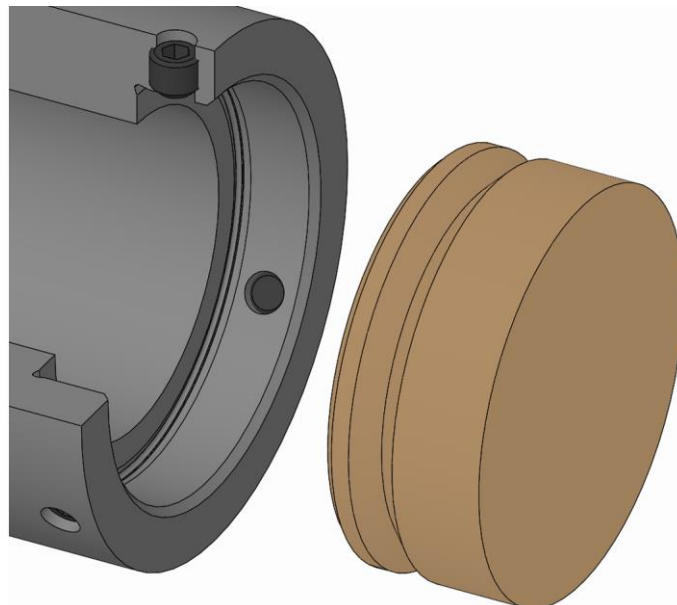

2. Take the changing part out of the product.

## 10.4 Removal of the clamping element

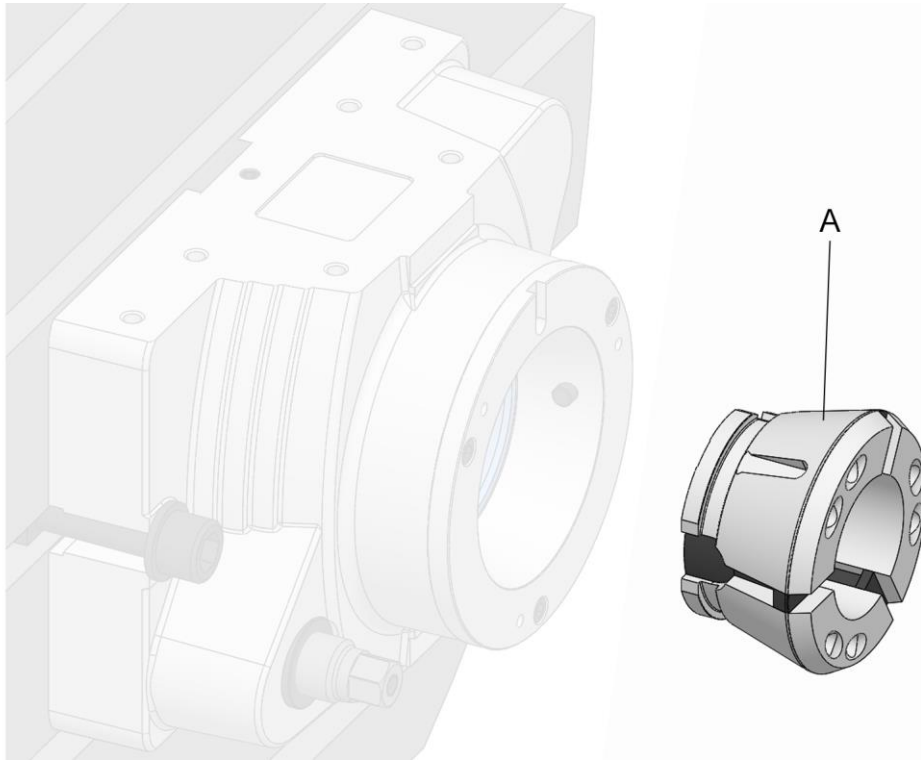

A Clamping head [clamping element]

Special aids needed:

■ Changing fixture

1. As described in the »Preparing the machine for removal« chapter, prepare for the following steps.
2. Move the clamping device into release position.

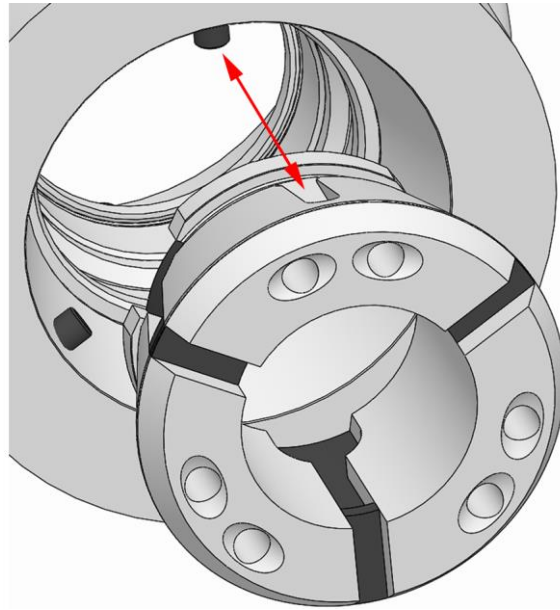

## WARNING

**Serious crushing injuries caused by reaching into the coupling / slot area in the clamping head or into the changing fixture!**

- During actuation, never reach into the coupling / slot area in the clamping head or into the changing fixture.

3. Remove the clamping head from the product with an appropriate changing fixture.



## 10.5 Removal of the product

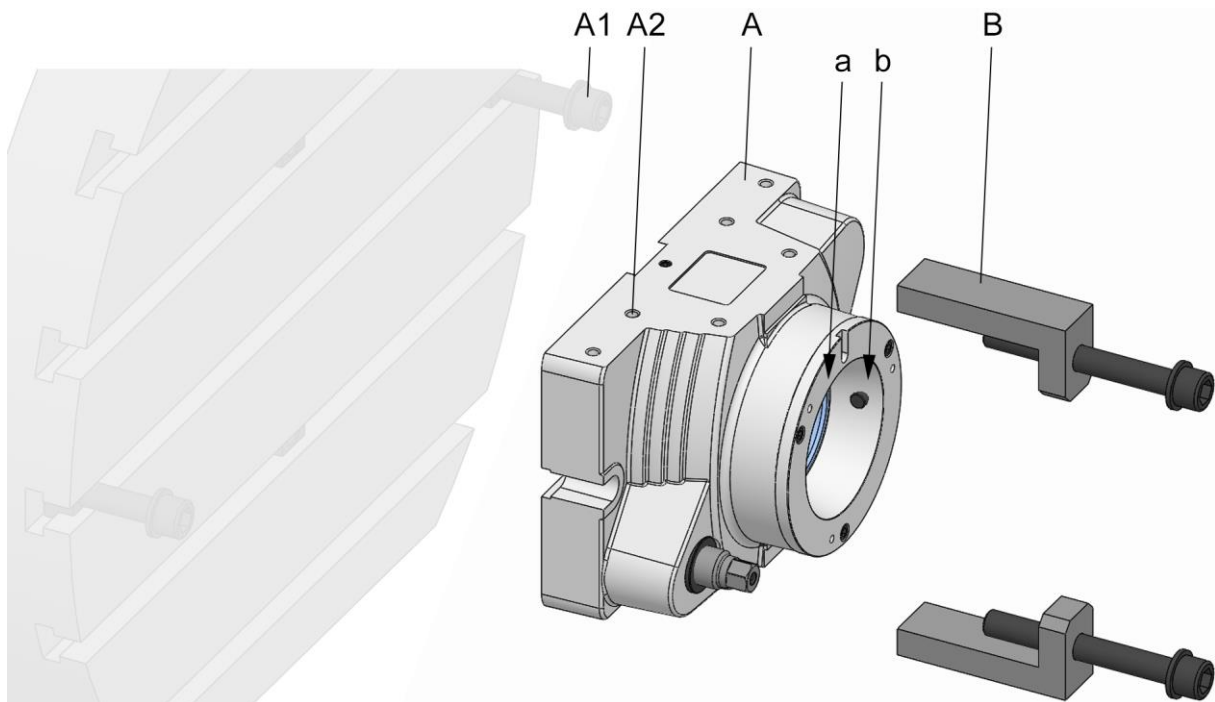

- A Product
- A1 Fixing screws on the product
- A2 Transport thread on product
- B Clamping bracket
- a Test surface, product face run-out
- b Test surface, position product

1. As described in the »Preparing the machine for removal« chapter, prepare for the following steps.

## 10.5.1 Removal of the product from the machine

1. Depressurize the hydraulic unit.
2. Attach any lifting gear that may be required.
3. If necessary, fit the mounting aid onto a vertically suspended spindle.

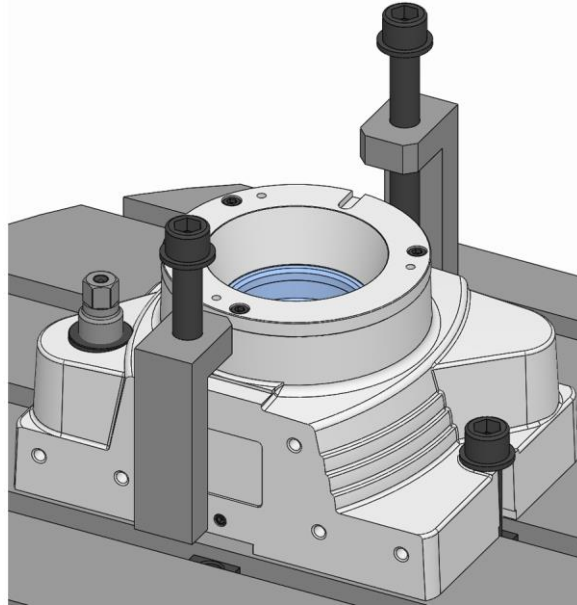

4. Where required, remove the clamping brackets from the product and the machine table.

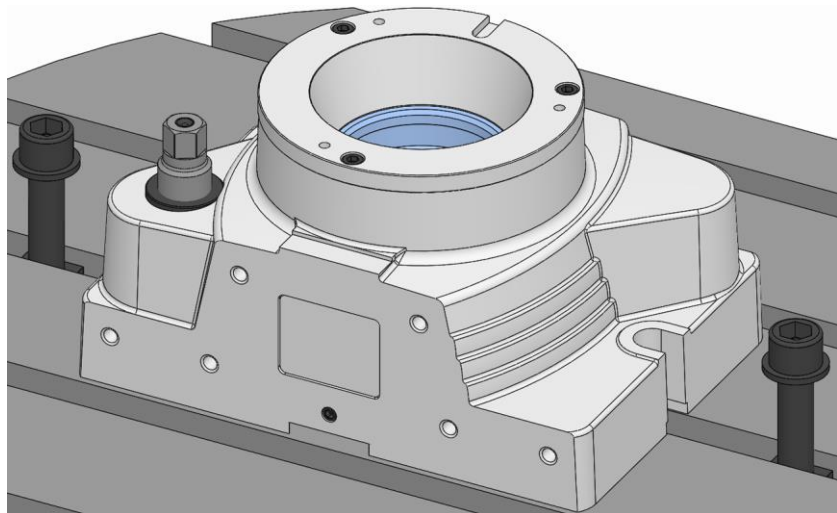

5. Unfasten and remove the fixing screws on the product.

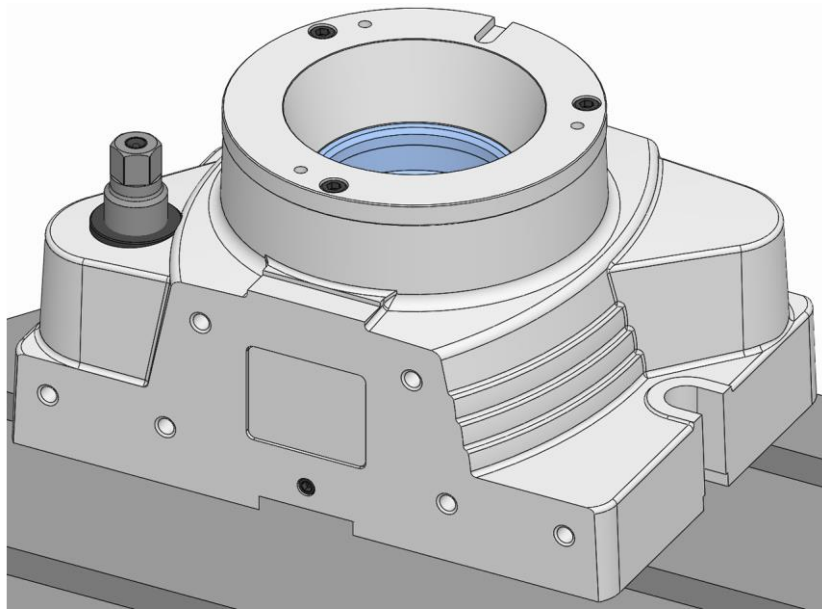

6. Remove the product from the machine table.

# 11 Maintenance

## 11.1 Maintenance safety



### WARNING

**Serious injuries caused by parts being ejected centrifugally after a loss of clamping power!**

- Maintain the maintenance and cleaning intervals of the product at all times.
- It is essential to check the maintenance status of the product at regular intervals with a structural clamping force measurement.



### CAUTION

**Health risks caused by incorrect handling of cleaning agents!**

- Pay attention to hazard specifications and the safety data sheet of the manufacturer.



### INFORMATION

If necessary, use any forcing / extraction threads in the components of the product, changing parts or clamping elements.

## 11.2 Maintenance schedule

The following sections describe the maintenance work needed to ensure optimum and fault-free operation.

If increased levels of wear are detected during regular checks, shorten the maintenance intervals to reflect the actual rate at which signs of wear appear.

Contact the manufacturer for questions relating to maintenance work and maintenance intervals [see »Contact« chapter].

Interval	Maintenance work
daily	Visual inspection of clamping and mating surfaces for signs of wear, nicks and cracks [see »Visual inspection« chapter]
	Visual inspection of rubber on clamping element for signs of wear, nicks and cracks [see »Visual inspection« chapter]
	Complete cleaning if heavily soiled [see »Cleaning« chapter]
	Conduct a structural clamping force measurement
weekly or after 40 operating hours*	Remove the clamping element [see »Removal of the clamping element« chapter]
	Clean the clamping element, clamping taper and coupling area [see »Cleaning« chapter]

Interval	Maintenance work
	Lubricate the product [see »Lubricating the product« chapter]
six-monthly or after 1500 operating hours*	Completely clean the product [see »Cleaning« chapter]
	Lubricate the product [see »Lubricating the product« chapter]
with storage	See »Storage« chapter

\* depending upon which stipulation is achieved first  
Table 18: Maintenance table

## 11.3 Cleaning

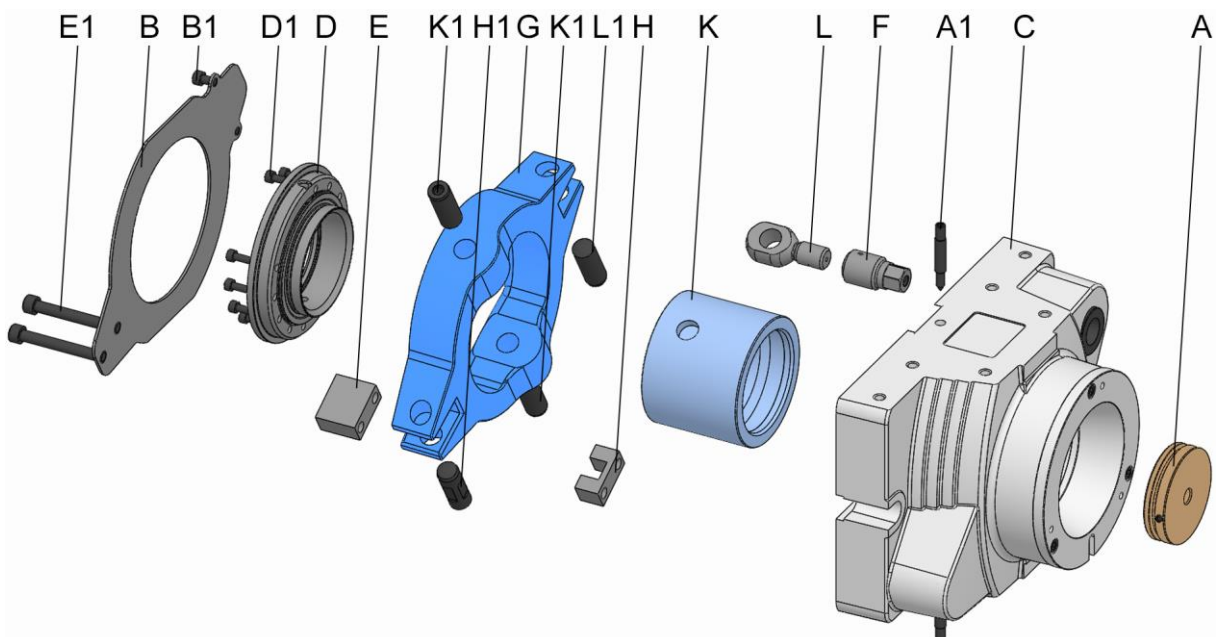

- A Base end-stop
- A1 Clamping screws, base end-stop
- B Cover
- B1 Cover fixing screws
- C Housing
- D Basic limit stop carrier
- D1 Fixing screws on the basic limit stop carrier
- E Mounting block 1
- E1 Mounting block fixing screws
- F Actuating screw
- G Rocker
- H Mounting block 2
- H1 Mounting block pin
- K Coupling
- K1 Coupling pin
- L Bearing journal
- L1 Bearing journal pin



## WARNING

**Eye injuries and cuts caused by failure to wear protective clothing during cleaning operation!**

- Never use compressed air to clean the product.
- Also wear the following items of personal protective equipment, in addition to the basic equipment:



## NOTE

**Damage to seals caused by the wrong solvent!**

- To clean the product, never use a solvent that attacks and damages the sealing elements installed. Those installed sealing elements can be made of NBR, Viton and PUR materials.
- To clean the product, never use a solvent that contains ester, nor a polar solvent.



## NOTE

**Damage to clamping elements caused by the wrong solvent!**

- To clean the product, never use a solvent that contains ester, nor a polar solvent.



## NOTE

**Damage to materials caused by incorrect installation of sealing elements!**

- Replace missing or damaged sealing elements.
- Ensure that the sealing elements do not fall out or get damaged during installation / removal, and apply a thin coat of grease if necessary.

Cleanliness of the relevant limit stop and guide diameter are essential for achieving axial and face run-out tolerances.

1. Remove the changing parts and the clamping element from the product [see »Removal of changing parts« and »Removal of clamping element« chapters].
2. Remove the product from the machine [see »Removal of the product« chapter].



## WARNING

### **Serious injuries caused by imbalance resulting from incorrect reassembly!**

- The product components must be installed back in the same position.
- If necessary, mark out the relative positions of components prior to disassembly.



## NOTE

### **Damage to materials caused by incorrect Removal of the product!**

- More extensive disassembly than shown on the exploded drawing is prohibited.

3. Dismantle the product as shown on the exploded drawing. Pay attention to the following during disassembly:
  - To remove the cover from the housing, the cover fixing screws and the mounting block fixing screws must be removed.
  - To remove the rocker, turn the actuating screw clockwise until the actuating screw no longer engages in the thread of the housing. When turning the actuating screw, guide the rocker in a parallel manner.
4. Clean all oil and grease residues off all components with an ester-free, non-polar, soft, lint-free cloth and check for visible signs of damage.
5. Assemble the product as shown on the exploded drawing. Pay attention to the following during assembly:
  - Replace worn or damaged fixing screws.
  - Tighten all fixing screws to the specified tightening torque [see nomenclature and/or »Screw tightening torques« chapter]. When tightening the screws, do so evenly to prevent any distortion under load.
  - Only apply lubricant to the mechanical mating surfaces. Pay attention to notes about lubricants [see »Use of lubricants« chapter].
  - Avoid too much lubricant on the locating face because this can cause face run-out errors.
  - Apply grease to the sealing elements [for example O-rings, rectangular rings] and sealing surfaces. Pay attention to notes about greases [see »Use of lubricants« chapter].

- Before inserting the rocker in the housing, the bearing journal and the actuating screw must be screwed together. For this, the total length of the two connected components must match the dimension of 101mm.
  - Install the mounting block pin with its faces arranged parallel to mounting blocks 1 and 2.
  - Install the rocker as far as possible in the housing. To install the rocker deeper, turn the actuating screw counter-clockwise up to its limit stop. When turning the actuating screw, guide the rocker in a parallel manner.
6. Lubricate the product [see »Lubricating the product« chapter].
  7. Check the total stroke of the clamping device [see the »Checking the total stroke« chapter]

## 11.4 Visual inspection

Perform a daily visual inspection of the product to identify any damage to the product at an early stage.

Check the product for cracks and damage, in particular on the clamping and end-stop surfaces.

The rubber on the clamping element also needs to be examined for cracks and signs of damage.

A check is also required to ensure that all fixing screws are tightened down.

If damage is detected, the relevant components must be exchanged immediately for genuine spare parts from the manufacturer.

Complete cleaning of the product is required if heavily soiled [see »Cleaning« chapter].



## 11.5 Lubricating the product



### **DANGER**

**Serious injuries caused by workpiece being ejected centrifugally due to insufficient lubrication of the product!**

- Never drop below the lower limit value for clamping force [see »Clamping force diagram« chapter].
- Always comply with the maintenance intervals [see »Maintenance schedule« chapter].

Lubrication takes place every time the system is cleaned, maintained or assembled, and also when required.

The product is equipped with grease nipples.



### **WARNING**

**Collision impact and cut injuries can be caused by slipping when applying grease with a piston-actuated grease gun!**

- Ensure that the piston-actuated grease gun is positioned correctly.

1. With the help of the piston-action grease gun [not included in the scope of delivery], squeeze grease into the grease nipple until no more grease can be injected.
2. At all lubrication points, remove escaping, consumed or surplus grease, and dispose of it in accordance with locally enforceable legislative provisions.
3. After lubrication, perform the entire stroke several times.

## 11.6 Use of lubricants

To achieve ultimate performance from the products, use the specified lubricants.

Only use grease that complies with the fundamental requirements governing adhesion, pressure resistance and solubility in coolants. Furthermore, there must be no particles of dirt in the grease because these cause an operational malfunction if they come between two interference fit surfaces. For this, the following lubricants are recommended:

### GP 355 universal grease

[see the HAINBUCH product catalogue]

Alternatively:

Lubricants	Manufacturer	Product designation
Grease	MicroGleit	GP 355
	Klüber	QNB 50
	Zeller & Gmelin	DIVINOL SD24440
	Bremer & Leguill	RIVOLTA W.A.P.

Table 19: Selection of lubricants



#### NOTE

#### Malfunction of the product due to a combination of different greases!

- Never mix different greases with one another.
- Clean the product completely before using a different grease.

A piston-actuated grease gun can be used to apply the grease. The piston-actuated grease gun is filled with the selected grade of grease, which is then pressed into the product. For this, the piston-actuated grease gun has a pointed mouthpiece.

## 12 Disposal

If no agreement exists for return or disposal, send dismantled components off for recycling.



### NOTE

**Substantial damage to the environment can result from incorrect disposal of environmentally hazardous substances!**

- Lubricants, auxiliary materials and operating fluids are governed by legislation for the processing of special-category waste: All disposal to be performed by authorized waste disposal specialists.

Catch exchanged oils and greases in suitable containers and dispose of them in accordance with applicable local provisions.

The local municipal authority or specialist waste disposal companies can provide information about environmentally compliant disposal.

## 13 Faults

The following chapter describes possible causes for faults, and the work involved in remedial action.

If multiple faults occur, shorten the maintenance intervals in accordance with actual load levels.

Contact the manufacturer if faults occur that cannot be remedied by following these instructions [see »Contact« chapter].

### 13.1 Procedure with faults

This applies in all cases:

1. With faults that constitute an immediate danger to people or capital equipment, press the Emergency Stop button on the machine tool immediately.
2. Establish the cause of the fault.
3. If troubleshooting requires work to be conducted in the danger area, switch the machine tool into set-up mode.
4. Notify the person on location of the fault immediately.
5. Depending on the type of fault, get it remedied by authorized and appropriately skilled specialists.



#### **INFORMATION**

The troubleshooting table in the following section provides information about who is authorized to remedy a given fault.

6. In the event of a fault not caused by the product, the fault may be caused by something close to the machine tool. For this, refer to the operating instructions of the machine tool.

## 13.2 Fault table

Fault	Possible cause	Remedial action	Remedied by
Defective axial strokes in the clamping device	Dirt in the parts in the power flow	Remove, dismantle and clean the clamping element and clean the clamping device if necessary	Skilled specialist
	During assembly, the total length of the bearing journal was not maintained with the actuating screw bolted down	Remove the clamping device, correct the total length and reinstall the clamping device [see »Cleaning« chapter]	Skilled specialist
Clamping element cannot be swapped in or out	Defective axial strokes in the clamping device	See fault »Defective axial strokes in the clamping device«	
	Workpiece outside the clamping width diameter	Use a suitable clamping element	
	Mechanical friction is too great [idling moment >5 Nm]	Lubricate the clamping device	
Clamping force is too weak	Incorrect lubrication condition	Check lubrication of the clamping device and correct if necessary	Skilled specialist
	Axial actuating force is too weak	Check the tightening torque of the actuating screw and correct if necessary	
	Stroke limitation by the workpiece end-stop	Use an appropriate workpiece end-stop	
Clamping force is too high	Axial actuating force is too high	Check the tightening torque of the actuating screw and correct if necessary	Skilled specialist
Spread of clamping forces	Incorrect full tightening of the actuating screw	Tighten the actuating screw to the specified tightening torque	Skilled specialist
Geometry deviation on the workpiece	Concentricity error on the clamping device	Check axial run-out of the clamping device and correct if necessary	
	Face run-out error of the clamping device	Check face run-out of the clamping device and clean the mating surfaces if necessary	Skilled specialist
	Dirty end-stop area	Remove the workpiece end-stop and clean the mating surfaces	

Fault	Possible cause	Remedial action	Remedied by
	Dirty coupling area in the clamping element	Remove the clamping element, clean the coupling area and the clamping element	
	Dirty clamping taper	Remove the clamping element and clean the clamping taper	
	Geometry error on the workpiece due to incorrect type of clamping element	Use a suitable clamping element	
	Elastic distortion	Reduce the clamping force to the level applicable for the clamping device and the workpiece Check the workpiece material	
	Clamping force is too high	Reduce the clamping force to the level applicable for the clamping device and the workpiece	
	Incorrect type of clamping element	Use a suitable clamping element	
Indentations on the clamping surface	Dirty clamping element	Clean the clamping element	Skilled specialist
	Damaged clamping element	Replace the clamping element	
	Dimensional difference between workpiece diameter and clamping elements is too great	Use clamping element with a suitable clamping diameter	

Table 20: Fault table

### 13.3 Commissioning after a fault has been remedied

After the fault has been remedied, perform the following steps to recommission it:

1. Reset the emergency stop equipment.
2. Acknowledge the fault on the control unit of the machine tool.
3. Ensure that no-one is in the danger area.
4. Start the machine tool.

## 14 Annex

### 14.1 Contact

The following hotlines are available to you for orders, schedule tracking and emergencies.

#### **Order hotline**

Ordered quickly, supplied swiftly. Just phone:

+49 7144. 907-333

#### **Tracking hotline**

Current status of your order? Just call:

+49 7144. 907-222

#### **24 hour emergency phone line**

Has a system crash occurred, or some other technical emergency?

Our experts are there for you around the clock:

+49 7144. 907-444

For advice or help, you can contact the sales partners and service staff listed in [www.hainbuch.com](http://www.hainbuch.com).

### 14.2 Manufacturer certification

Manufacturer certification is supplied with the product and with this manual.







## Index directory

### A

Accessories, optional	
Face driver adaptation .....	28
Jaw module .....	27
Magnet module .....	27
MANDO Adapt .....	28
Morse taper adaptation .....	28
vario part end-stop system .....	28
vario quick end-stop system .....	29

### Accessories, required

Clamping head .....	27
Workpiece end-stop .....	27

### Accessories, special aid

Manual changing fixture .....	29
-------------------------------	----

### Accessories, special aids

Key .....	29
Pneumatic changing fixture .....	29
Torque wrench kit .....	29

### B

Balancing quality .....	21
Brief description .....	26

### C

Checking the total stroke .....	71
Cleaning .....	93
Copyright .....	9

### D

Definition of terms .....	8
---------------------------	---

### E

End of production .....	78
Environmental protection .....	20

### F

Fault table .....	101
Faults .....	100

### H

Hazards .....	16
---------------	----

### I

#### Installation

Changing part .....	63
Clamping element .....	61
Preparation of the machine .....	57
Preparation of the product .....	58
Product .....	58
Installation safety .....	54

Intended use .....	13
--------------------	----

### K

Key to symbols .....	7
----------------------	---

### L

Layout .....	26
Liability .....	9
Limits of use .....	30
Lubricants .....	20, 98

### M

Maintenance schedule .....	92
Misuse .....	14

### O

Operating conditions .....	25
----------------------------	----

### P

Packaging .....	52
Performance values .....	21
Personnel requirements .....	11
Electricians .....	12
Hydraulics specialist .....	12
Pneumatics specialist .....	12
Skilled specialist .....	12
Trainees .....	13

Preservation .....	53
--------------------	----

#### Protective equipment

Hair net .....	15
Hard hat .....	16
Protective gloves .....	15
Protective goggles .....	15
Safety footwear .....	15
Workplace clothing .....	15

### R

#### Removal

Clamping element .....	87
Preparation of the machine .....	81
Product .....	89
Removal of changing parts .....	81

### S

#### Safety

Commissioning .....	70
General .....	11
Maintenance .....	92
Removal .....	79
Transport, packaging, storage .....	50

Scope of delivery .....	9	Tests .....	72
Screw tightening torques		Transport inspection.....	51
Aluminum components .....	57	Transportation, internal .....	52
Metric control threads .....	56	Type designation.....	25
Spare parts .....	10	<b>U</b>	
Speed .....	22	Unpacking .....	52
Storage .....	53	Use.....	30
Symbols on the packaging.....	51	<b>W</b>	
<b>T</b>		Warranty.....	10
Technical data.....	21		



HAINBUCH GMBH · SPANNENDE TECHNIK

Postfach 1262 · 71667 Marbach / Erdmannhäuser Strasse 57 · 71672 Marbach · Germany

Tel. +49 7144.907-0 · Fax +49 7144.18826 · [verkauf@hainbuch.de](mailto:verkauf@hainbuch.de) · [www.hainbuch.com](http://www.hainbuch.com)

**24 hour emergency phone line** + 49 7144.907-444