

New format.
New look.



report

25

September 2010

The magazine for customers,
employees, and friends

1500/10.10 Teile-Nr. NK.80001/0070 Subject to technical changes.

LIGHTER AND EASIER

The new lightweight series – Clamping devices made of carbon

- as much as 2/3 lighter than the standard version
- reduced energy costs
- faster spindle acceleration
[increased productivity]
- identical clamping force values



Call: +49 [0]7144.907-333
Click: www.hainbuch.com

More productivity
Lightweight clamping devices

Know-how transfer
Seminar and event program »live«

The energy savers are coming

Clamping solutions with savings potential



CONTENTS

PRODUCTS

- 4 Lightweight clamping devices**
They are coming on strong now.
- 8 Product news**
New sizes, new technologies and entirely new models.
- 12 Electromechanical actuator**
The energy-efficient future has begun.
- 14 Quick change-over systems**
Job-oriented, high-speed production.

SERVICE & MORE

- 16 live – seminars and events**
Stay informed and competitive.

INTERNATIONAL

- 18 USA goes forward**
New building. New service.
New president.
- 19 Export market China**
HAINBUCH and the Middle Kingdom.

HIGHLIGHT

- 20 Goldjupiter®**
And the »business oscar«
goes to ... HAINBUCH.

INTERNAL

- 22** New employees | Training partnership |
Trainee program »cultus« |
Permanent learning »ErfahrungsReich« |
HAINBUCH sports club »SV Spanntreff«

IMPRINT

HAINBUCH GMBH
SPANNENDE TECHNIK
Erdmannhäuser Straße 57
DE-71672 Marbach
Tel. +49 [0]7144. 907-0
Fax +49 [0]7144. 18826
sales@hainbuch.de
www.hainbuch.com

EDITORIAL



Project »Future«

Dear customers, dear employees, dear friends,

No matter which industry journal I open, regardless of which newsletter lands in my email inbox, for weeks one topic has been dominating: Energy-efficiency, and this applies for all industries. Everyone is talking about conserving resources, CO₂ minimization, environmental responsibility, sustainability.

Obviously so are we. These issues trigger our Swabian ambition for invention and finally there is something like a spirit of optimism in the air. A new chapter in [clamping] history has been opened and we have already filled the first pages. Soon it will be hard to overlook our new lightweight clamping devices and the lightweight electromechanical actuators.

They had been hardly introduced when they made already headlines. Obviously this was quite pleasing to us, however it was not really a surprise. In times of high operating costs performance, price, and service no longer play the major role in the acquisition of a machine, for some time now energy-efficiency has surpassed these factors. This is not only good for your business it is also good for our planet.

We are very concerned about both. Consequently there is a lot of passion, energy and also a bit of Einstein in our new developments: »Everything should be made as simple as possible, but not one bit simpler.« We have followed this dictum as you will soon see.

Gerhard Rall
CEO, HAINBUCH GmbH

The new lightness

LIGHTWEIGHT IS COMING ON STRONG. RIGHT THROUGH ALL INDUSTRIES AND MARKET SEGMENTS. NOW LIGHTWEIGHT IS THE CHOICE, FOR CLAMPING DEVICES AS WELL.

Whether aerospace, the automobile industry motor sport, or tennis, golf etc. for many years a clear trend toward lightweight designs has made its progress. In the aerospace industry each kilogram of payload launched into space costs several thousand Euro. This explains the great demand to save weight wherever possible. Lightweight construction is also a priority in motor sports. Often merely a few hundredths of a second mean the difference between victory and defeat, and with components subjected to the most extreme levels of force. And in the machine tool industry? Here the concern over rising maintenance costs is increasingly becoming a central issue for companies, since power costs have seen extreme increases in recent years. Market analyses have forecasted the trend to lightweight products for years. HAINBUCH also addressed these issues early and responded to the challenges of lightweight clamping devices and their special manufacturing processes by devoting research and development resources in these areas.

But what is a lightweight clamping device? For once there is a lightweight design. The objective here is to keep the construction as slender as possible and avoid unnecessary wall thicknesses and masses. In this regard a so-called FEM calculation that precisely indicates whether a clamping device is ideally loaded are an aid. Another important point is material lightweight design. In this case, in addition to lightweight metallic materials, such as aluminum and titanium, recently high-performance plastics of different composite materials have also gained ever greater significance.

HAINBUCH relies on carbon, i.e. carbon fiber reinforced plastic, as the basis for the new lightweight

generation of clamping devices. With this manufacturing process carbon fibers are embedded in a plastic matrix in multiple layers. This results in a high-strength composite material in which strength and rigidity in the fiber direction is much greater than it is transverse to the fibers. HAINBUCH lightweight clamping devices have a static radial clamping force of up to 170 kN. Therefore it is indispensable for the configuration of the components that the layers of the fiber mats must be designed to meet the requirements imposed by the occurring load. The design is based on complex computer calculations.

THE SAME CLAMPING DEVICE TYPES CAN BE AS MUCH AS 70 % LIGHTER

An additional advantage offered by composite materials is the possibility of combining a wide variety of materials. Thus a HAINBUCH lightweight chuck consists not only of carbon but of several individual materials. Steel represents the lowest proportion and is still used only if components slide on each other, or are responsible for the accuracy when joining individual parts. This fact made it strictly necessary, already at an early stage of the project, for HAINBUCH to acquire the necessary carbon manufacturing know-how. Today HAINBUCH manufactures all the components of the new clamping device generation in-house. It is possible for the same clamping device type to be as much as 70 % lighter. The forces occurring when clamping are absorbed by the carbon fiber reinforced plastic. This pays for itself. The weight of the clamping device and work piece plays a major role particularly for smaller machining centers or machines that function in accordance with the pickup principle.

The more dynamic the machine the lower the weight of the moving masses that must be maintained. This is the only way to achieve reasonable traverse speeds of the individual axes. In addition, this protects the machine components, such as spindle and drive. The machine accuracy is also increased. According to the Employers' Liability Insurance Association in Germany, the weight limit for clamping devices or pallet systems that may be changed manually is 15 kg. Lightweight clamping devices are often the solution.

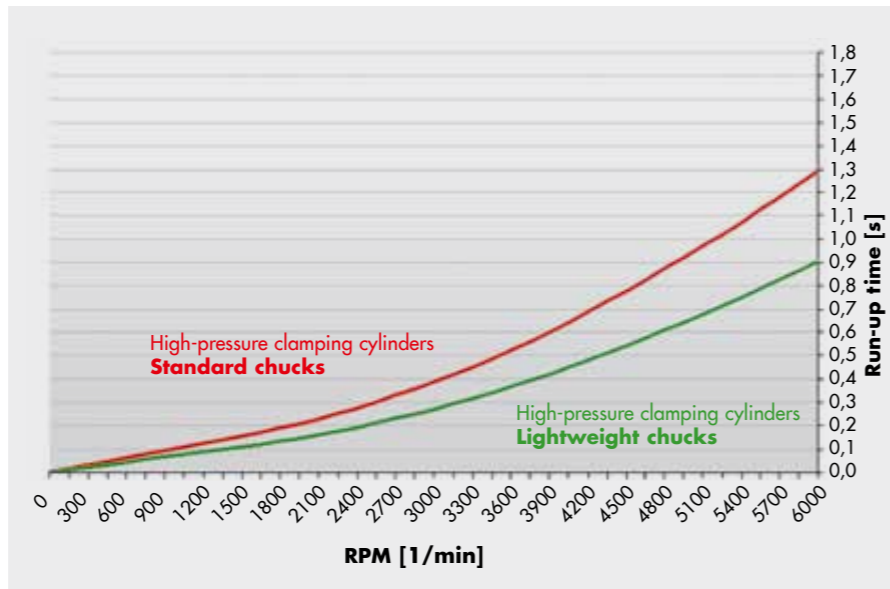

The lightweight MANOK plus stationary chuck weighs just 8 kg, the standard version of steel, on the other hand, weighs 24 kg.

But in addition to the trend toward the energy-efficient machine of the future and protecting machine and resources, there is yet another reason for the use of lightweight clamping devices:

The increase in productivity. In this regard the crucial factors are shorter change-over times and the cycle times of the individual components. Modern machine tools have increasingly gained dynamics.

30 % FASTER SPINDLE ACCELERATION AND HIGHER RPM

Higher RPM and faster spindle acceleration are important factors in this regard. This is precisely the point where the advantages of lightweight clamping devices are fully brought to bear, because for highly-dynamic machine tools the mass moment of inertia must be kept low. This is only way that short spindle acceleration times as well as delays are possible. As an example using a lathe shows clearly: Simply replacing a TOPlus combi pull-back clamping device made of steel with its equivalent lightweight clamping device made of carbon, can reduce the time for spindle acceleration to maximum speed by 30 %.

GREATER PRODUCTIVITY AND A PART PRODUCTION RATE BY AS MUCH AS 6 %

It is not just the reduced power costs due to the lower mass that make a difference. More precise tests also showed a part production rate by as much as 6 %. Thus for highly dynamic machine tools that machine steel chuck parts with cycle times of approx. 60 seconds, in multi-shift operations the annual capacity can quickly be increased by ten thousand components. The potential is correspondingly higher for materials such as brass or aluminum.



Sample application of the new TOPlus lightweight chuck for machining a shaft.

Thus the strategy of the lightweight clamping devices increases productivity with up to 2/3 less weight, and therefore results in 30 % faster spindle accelerations. Due to the low power consumption and the associated reduced energy costs a lightweight clamping device is not only energy-efficient, it is also environmentally-friendly. Not to mention advantages such as increased process reliability through lesser load on machine components, and a highly user friendly set-up due to the low weight. There is also the fact that lightweight clamping devices make a contribution to higher accuracy.



TOPlus chuck, TOROK manual chuck, MANOK plus stationary chuck – are all available in the lightweight version.

B-Top + MANDO Adapt Conversion for I.D. clamping

Now there is a practical solution for all who value the B-Top 315 jaw chuck with its flexible jaw quick change-over system, but do not want to dispense rigidity and precision of a MANDO mandrel. Remove the guard bushing, insert the centering bushing. Then you can insert all the size 65 MANDO mandrel adaptations that you also utilize in our SPANNTOP nova chucks. A genuine innovation that enables a fast set-up without alignment. Pull-back effect, high accuracy and rigidity included – at a concentricity on the mandrel taper of < 0.015 mm. Clamping from 13 to 120 mm is feasible. However, you cannot disassemble the centering bushing when the chuck is on the machine. Chuck and bushing are now one unit: A unit that is suitable for all users who do not need the capacity in its full scope, as it reduces the design from 104 to 69 mm. On the plus side the entire unit can also be implemented for any jaw chuck brand. Just ask us.



Product development

LOOK FORWARD TO EVEN MORE INNOVATIVE, FLEXIBLE AND PROFITABLE
CLAMPING SOLUTIONS FOR YOUR MANUFACTURING.

MANDO Adapt deadlength Mandrel adaptation

Now there is also a mandrel solution for the deadlength SPANNTOP nova chuck: The MANDO Adapt deadlength T811 with quick change-over interface. The particularly practical feature of this solution that only clamps radially, without a drawbolt: Clamping bushings, end-stops and end-stop blanks are identical to the in-stock accessories for the MANDO T212 mandrel. The new deadlength MANDO Adapt is ideal for short blind bores and for all who are still looking for a suitable solution in regards to pick up issues.

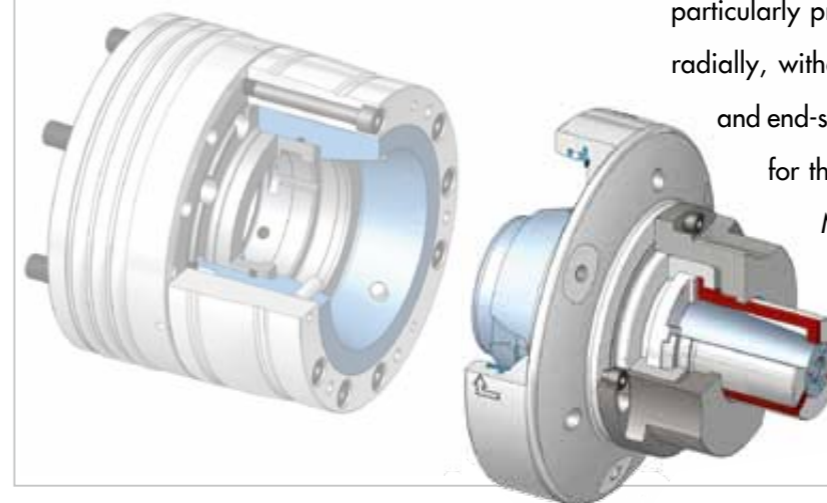

TOPlus chuck

Now also available in size 52

This chuck is a credit to its name. This is demonstrated not only by the results of our latest customer survey. More holding power, process reliability, vibration-dampening and the sealing, these are the strengths that our customers stated for the TOPlus. Finally, the hexagonal hit is now also available in size 52. The chucks and clamping heads are in stock so that we can quickly service the demand.



Vises

3 new models

An NC vise, a centric vise, and a multiple vise now complete the HAINBUCH portfolio for machining centers. From single clamping to double clamping with extremely large clamping widths, with this trio almost any clamping situation can be implemented. All three have an extremely high level of clamping repeatability. A housing that is virtually free of force even at full clamping force and a special clamping force implementation as well. Thus work pieces can be precisely clamped and positioned. In addition, the centric clamping vise has a spindle on top, which guarantees a particularly good progression of clamping force. The pull-back technology of the NC vise, which pulls the work piece plane-parallel onto the housing, saves the operator the time-consuming task of tapping the part down onto the rails.

The jaw that HAINBUCH offers as an accessory is also decidedly practical. A multi-functional »super jaw« with a special serrated step for 1st side machining, a step for 2nd side machining and a rail technology with which not only the clamping depth can be quickly adjusted, but that also enables clamping in the diagonal position and

attachment of the work pieces. There is also appropriate equipment for vertical handling. The manual vises are offered standard, hydraulic and pneumatic spindles are available upon request.



CENTREX magnetic pallet system

Lightweight automated

Continuous and secure clamping in automated implementation is delivered by the new lightweight magnet pallet system from the CENTREX family. Its strengths: The permanent magnetic locking mechanism, unlocking via electrical switch-off of the permanent magnets and the technical integration in a PLC. In addition a centric air blocking duct is also available as an option. Delicate components are optimally handled here, since neither work piece nor chips are magnetized.



QUADROK 4-side vise

Now in size 120!

For the previously available size 200 we now offer a smaller, more cost-effective standard solution, the QUADROK 120. Surrounding clamping on all four-sides with equal force, high repeatability in all axes, extremely short clampings, turning jobs up to 1000 RPM, and optimal material removal rates through active pull-back effect, with a maximum work piece size of 150 x 150 mm – these are the highlights of the practical all-around clamping vise. Thanks to the serration the user can not only screw on a wide variety of jaws, but can also use existing jaws and blanks. QUADROK is available in a manual version and a hydraulic version.



Film QUADROK in use:
<http://quadrok.hainbuch.com>

Big savings

MINIMUM ENERGY REQUIREMENTS, MAXIMUM PROFITABILITY:
THE NEW ELECTROMECHANICAL ACTUATORS ARE STINGY IN CONSUMPTION
AND BRILLIANT IN TERMS OF PERFORMANCE.

According to the media: »Medium-sized businesses are not just a job engine, they also drive ecological developments«. If this is true then energy consumption is clearly too high: Forexample, a so-called »modern« 5-axis machining center consumes approxi-

mately 44,000 kWh annually. This corresponds roughly to the annual energy consumption of 12 single-family homes or 228 refrigerators. However where is the savings potential of these energy hogs? Where are the solutions that are not only economical but that are also eco-logical? After all, industries with 65 % are respon-sible for a much greater share of energy consumption than the private households. So: The industry has also more responsibility.

HAINBUCH accepts this responsibility with again an apparent and amazingly simple solution: The new electromechanical actuator simply

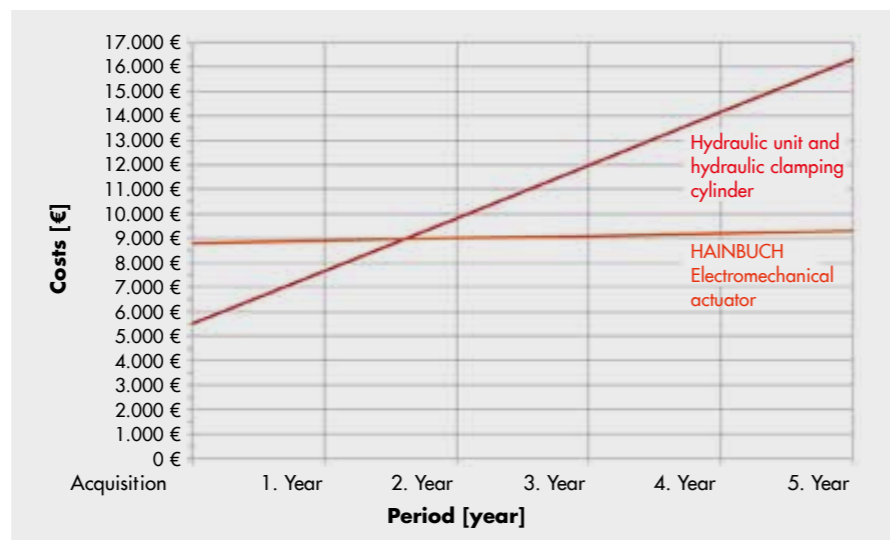

Energy costs shrink, performance grows: Even if the speed and direction of rotation are changed abruptly the electromechanical actuators from HAINBUCH maintain stroke position and clamping force.

dispenses with what consumes the most energy. For machines it is without a doubt the hydraulic system. It supplies permanently pressure and thus consumes permanently energy. By contrast, the electromechanical actuator only consumes power when it moves. Theoretically it is possible to dispense the hydraulic system which is oil and maintenance intensive. By doing so not only the high initial costs are saved but you also go easy on the environment.

The energy-efficient electromechanical actuator is extremely economical by design and scores high marks via reduced powerloss, more

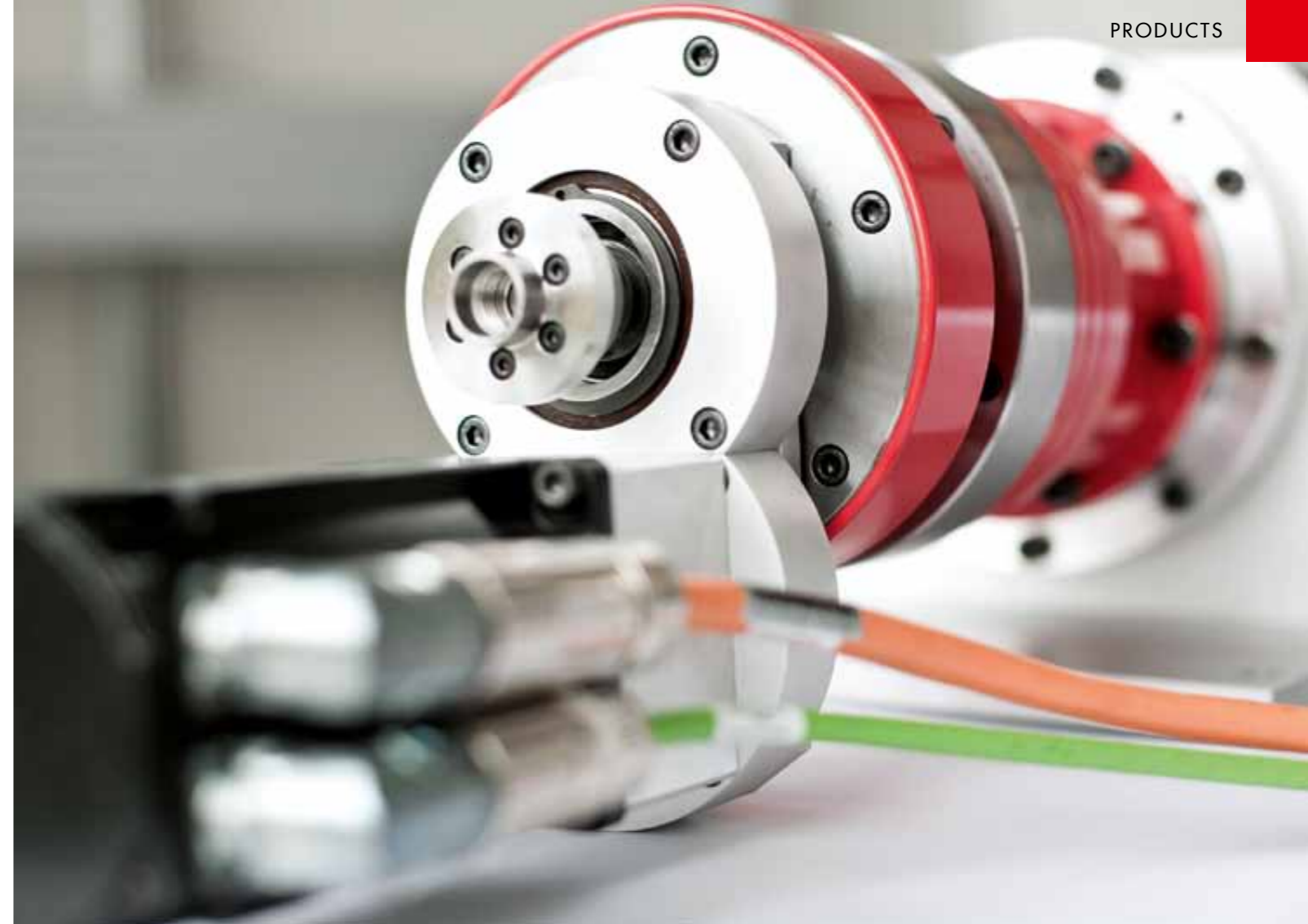

Electric full vise and servomotor

sensitive clamping force control during machining, and positionally accurate, fast actuation of different stroke positions. Nor is it necessary to move any further than the necessary opening and clamping stroke with the new technology. The electro mecha-

nical actuator is available either with full through passage or as a new full electromechanical actuator. Return on Investment [ROI] approx. 1.5 years.

 **Electromechanical actuator in use at:**
<http://elektrospanner.hainbuch.com>



Electric hollow vise and servomotor

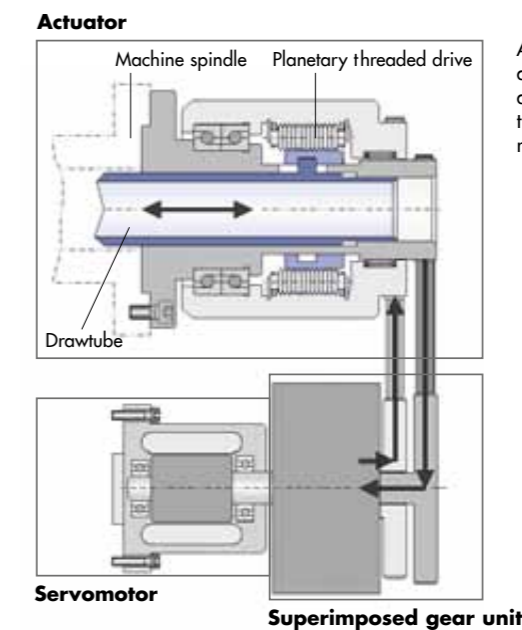

A planetary threaded drive, a superimposed gear unit, and a servomotor – with this trio HAINBUCH wants to revolutionize machine tools.



The HAINBUCH quick change-over systems

capteX – the manual change-over solution

- Change-over of clamping devices in a few seconds, max. 2 minutes, depending on size – without alignment
- 1 central locking screw + torsional safety
- With or without capacity [to 52 mm]
- For all clamping devices to approx. 200 mm O.D.



centroteX – the crane-changing solution

- Change larger clamping devices in 2 to 10 minutes – with MonteQ mounting aid and load crane
- Locking via quick-acting closure screws and bayonet
- Clamping device actuation via bayonet
- Capacity > 52 mm
- For clamping devices up to approx. 350 mm O.D.

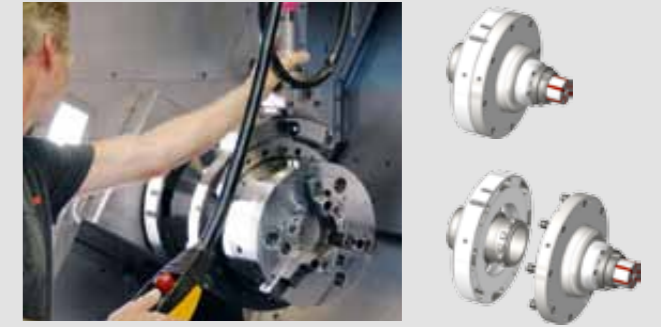

High-speed set-up

PRACTICAL, THAT THE HAINBUCH QUICK CHANGE-OVER SYSTEMS FIT ON EVERY MACHINE. EVEN BETTER THAT YOU ALSO EARN MONEY FASTER BECAUSE YOU CAN MANUFACTURE ON A JOB-ORIENTED BASIS.

Things are looking up again, the order situation is getting better, the machine park is used to full-capacity. But who has a) money to invest in expensive machines, or b) time to wait until the money is available? But speed is in demand right now – particularly for set-up times. The practical quick change-over systems from HAINBUCH focus on eliminating long set-up times. It's clear that if I have long set-up times, naturally I keep the set-up processes to a minimum and collect correspondingly all suitable work pieces. This isn't customer-oriented production, and it is certainly not effective for small batches. Nor is the jaw chuck that is liked best by everyone in this situation: Yes it can do everything, but not with the best results. In this case it is better for me to produce what my customer needs at the moment and to do it as quickly as possible. Then I also have the competitive advantage on my side.

Produce more in less time and above all produce the right things: Quick change-over systems make it possible. Within a few minutes, yes even seconds, the clamping device that is ideal for the machining is set up. Machine standstill times are shortened, production times increase accordingly. This is where a quick change-over system also pays for itself quickly. At an annual cost reduction of up to 30,000 Euro the initial costs pay back quickly, as our calculation example shows.

Moreover the workshop can be optimally standardized with such a quick change-over system, and this is particularly attractive for uniform production. Naturally,

when every machine is equipped with a uniform interface, flexibility increases incredibly and investment costs are increasingly reduced. However often customers only believe that the systems are really fast and precise after they have practically experienced it. One customer recently determined that what HAINBUCH said in the brochures was understated. Enthusiastically he then immediately ordered a quick change-over system and is now increasing his profitability on a daily basis.



capteX and centroteX in use at:
<http://captex.hainbuch.com>
<http://centrotex.hainbuch.com>

Quick change-over pays off!

Practical application values:

Clamping device change-over per shift	1
Shifts per day	2
Hourly machine rate	90 €
Savings when changing clamping devices	35 min.
Work days per month	20

Investment:

capteX	
MC adapter	1
Clamping device adapter	2
= approx. 8,250 € total investment	

ROI	< 3.5 months
Profit after 1 year	30.000 €

And don't forget:
 In the time that you save you can produce additional work pieces and thus increase your profit even more.

Added-value guaranteed

STAY INFORMED AND COMPETITIVE: WITH »live«
– SEMINARS AND EVENTS. FOR EVEN MORE
INDUSTRY KNOWLEDGE AND CLAMPING
TECHNOLOGY KNOW-HOW.

Our products are experienced totally differently live than they are experienced on paper. In dialog with you our speakers are rising to the occasion. Any-one who has ever visited one of our Technology Forums will confirm this.

Our training program »live« has something for everyone. For the pro as well as for the novice: The interactive, open seminars not only keep you fit in terms of the products and supply you with techniques to reduce set-up time, they also provide you with business management correlations. Would you rather have it individual? Training at your site or in our facilities? In this case our new customer-specific training courses are just right for you. They are designed precisely to meet your requirements and for your employees, and naturally the training classes are designed in close collaboration with you. This was exciting

live

interactive:
Seminars

Individual:
Training courses

Informative:
Technology
Forums

for Gunnar Waller of Robert Bosch GmbH: »The extremely intensive collaboration even in the concept phase and also later during the training proved to be the right decision for us. The employees who participated in the workshop were highly motivated to implement the approaches and ideas in our organization.«

At our Technology Forums that take place twice a year, for two days everything revolves around current topics that are relevant for the industry. External presenters as well as top-notch speakers are on the agenda. This know-how transfer is extremely exciting, and decidedly



entertaining to boot and it brings new knowledge that also pays off. »The time was well-invested«, summed up one participant »There were many new ideas for me. In terms of set-up time there is still a lot of optimization potential.«

This is running in 2011

Technology Forum

- January 27/28, 2011
- November 17/18, 2011

Seminars

- March 24, 2011
- May 19, 2011
- July 12, 2011
- October 18, 2011

We still have seats for the 18/19 November date. Info online at www.hainbuch.com
> News > Dates

Ask us for the seminar program »live 2011« or register now with: isabell.hauke@hainbuch.de

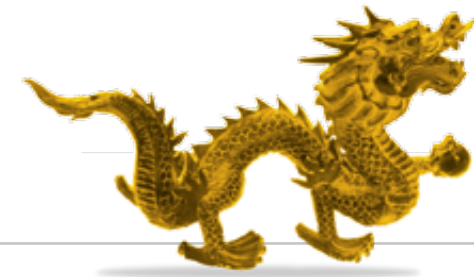

More power HAINBUCH AMERICA

The move took place some time ago, in November last year and no one misses the old building. After all, the new building is much more comfortable, more spacious, and the landlord had it built precisely to HAINBUCH America's specifications. But the new headquarters is not the only thing that has changed. The subsidiary has now also set up its own Service Shop, purchased two additional machines and has hired additional personnel. For example, in the Service Shop



clamping heads are ground, and end-stops and draw-tube adapters will also be manufactured there in the future. Now the US market can be more quickly and more effectively supported.

A good investment in the future, at precisely the right time. Large lots are increasingly contracted out to Asia and Mexico, the small and medium lots however remain in the USA. For these small and medium lots HAINBUCH has precisely the right clamping devices.

New manpower. With Hank Kohl as the new president HAINBUCH America has an experienced professional on board. The American with German roots has more than 25 years of experience in the machine tool industry. He has worked for American, German, and other European companies, established subsidiaries and positioned the enterprises in the North American market.



Kohl sees good chances for development in the North American market, as HAINBUCH has excellent clamping solutions, both in the rotating and in the stationary area. Only word has not gotten out yet.



Contact:

HAINBUCH America
Workholding Technology
10541 N. Commerce St.
Mequon, WI 53092
Tel. +1 414-358-9550
Fax +1 414-358-9560
sales@hainbuchamerica.com

A promising future CHINA IS BOOMING

World export champion Germany? The Middle Kingdom is doing its best to surpass us. With 10.8 % economic growth in 2010 booming China leaves Europe far behind with 2 to 2.5 % growth. HAINBUCH realized years ago that China is a promising market. However it is significantly more difficult to get a foothold there. Support in China plays an extremely critical role. Since our office in Shanghai cannot do this this alone we are taking the »indirect route« via machine tool manufacturers and work closely together with the subsidiaries of our German customers. In addition we have a service partner in the North, the company REC, a dealer in the south, the company of our former employee Li Zhou, and most recently a service technician in Shanghai, one of the most important economic regions. Thus we are prepared for the »economic miracle«, and its incredible potential.

China orders – some examples

Our core target groups are also located in booming China. Naturally we can score points there with decades of experience from domestic orders.

■ Large automobile manufacturer

Large project, start: 2008.
5 production lines delivered with HAINBUCH mandrels, number 6 is ordered. 4 additional production lines will follow by 2011.

■ Supplier to the automotive industry

3 gear hobbing centers.
The HAINBUCH clamping devices were delivered in July.

■ Machine manufacturer

9 machines for injector processing, 10 machines for processing swivel pins and ball hubs.



»Business oscar« for HAINBUCH

AMONG SEVERAL HUNDRED THOUSAND MEDIUM-SIZED COMPANIES IN GERMANY ONLY 100 HAVE A CHANCE FOR THE GOLDJUPITER. HAINBUCH IS NUMBER 27.



President of the Economic Committee Siegfried Auffermann, HAINBUCH CEO and Honorary Senator Gerhard Rall and the Secretary for Economy Baden-Württemberg, Ernst Pfister [left to right].



After last year's »Award for Medium-Sized Businesses« HAINBUCH can now extend its prize collection: The Wirtschaftskomitee Deutschland e. V. [Economic Committee registered association] awarded the company the »Goldjupiter«, one of the most prestigious business awards. According to the committee what tipped the balance in favor of HAINBUCH was the outstanding economic commitment, and the many years of exemplary training activities. »Completely different laws apply in a medium-sized company than compared to a large company«, explained HAINBUCH CEO Gerhard Rall. »We must skillfully combine success, obligation, and risk. This only works if we also feel responsible for the public welfare.«



New employees

THEY WORK AT HAINBUCH ...

... AND PERHAPS YOU WILL SOON BE WORKING WITH OUR NEW EMPLOYEES. BETTER AQUAINTANCE FOR THE PURPOSE OF JOINTLY DETERMINING NEEDS AND ORDER PROCESSING VERY MUCH DESIRED.



Frank Heimlich

Out of the office and on tour

Frank Heimlich has been our man for Northern Bavaria since January. Wherever the »clamping concerns« are pressing you. Whether the issue is orders, maintenance, or new products. From this point on we are supporting our white and blue state ourselves.

- He works for HAINBUCH because the combination of innovative products, customer benefits, and responsible management simply fits.

The second »Bavarian« is **Michael Kopp**. Since June he has been caring for everything south of the Danube. From his home office or directly on site. In this regard he cannot only discuss all the technical aspects of our products in great detail, he also knows what they can do for you.

- He works for HAINBUCH because he could immediately identify with the company and the clamping technology fascinated him from day one.



Michael Kopp

Active in-house

Ladies first, **Constanze Reetz** is the new face in export team, and in addition to Southeast Asia and Slovenia, she also supports our subsidiary in Italy. With everything that is required.

- She works for HAINBUCH because here the owner family still has the say and not some manager.



Constanze Reetz

Matthias Besemer was the first addition to inside sales in 2010. The standard clamping devices, customer information and support are his responsibility. For him the HAINBUCH products are not that new. He already dealt with our products when he was working for INDEX.

- He works for HAINBUCH because experience has convinced him of the product quality and the implementation possibilities, and because the awesome corporate culture simply produces the right mood for work.



Matthias Besemer

Tobias Häußermann is an old hand when it comes to HAINBUCH. He trained as an industrial mechanic at HAINBUCH, pursued further technical education and after successfully concluding his studies he is back again. He is your partner for special clamping solutions.

- He works for HAINBUCH because he liked the family atmosphere when he started here, and the fact that the same atmosphere is still here today.



Tobias Häußermann



Signed

TRAINING PARTNERSHIP

A good initiative, that the International Chamber of Commerce established with government and businesses in 2008. Schools and companies should cooperate more closely in education matters. Recently HAINBUCH and the Anne-Frank-Realschule in Marbach have been one of the German »education teams«. Theory and practice are tightly meshed here. Everyone profits from this

arrangement: HAINBUCH, because the school system becomes more transparent, the practitioners who better understand the theoreticians, and vice versa. The students learn a lot about professional and company practice at trainings like »How to write an application« and internships. In short: a great exchange of information.



Monika Mayer-Schuhmacher, principal of the Anne-Frank-Realschule, and Hans-Michael Weller, Chief Technical Officer of HAINBUCH, pursue a common course for the future in terms of education.



MAKING COFFEE, MAKING COPIES? NOT AT HAINBUCH.
THE **cultus** TRAINING PROGRAM FOR TRAINEES HAS
TOTALLY DIFFERENT PRIORITIES IN THIS REGARD.

cultus is cult

At HAINBUCH it is not just the product line that is modular, the training program for the interns, which often is a bit unconventional, is also based on this principle: cultus [Lat. = education] is comprised of four areas that in total ensure an appropriate »cultural« education. In addition to the blocks Products/Technology, Methods/Specialized knowledge and preparation for the tests, business etiquette is also part of the program. For HAINBUCH this is significant. After all the social conducts are at least as important as knowledge of the products, technical relationships, DP basics, or the right way to talk on the phone. The trainees learn reliance and responsibility in internal seminars and through excursions to other companies, look beyond the rim of the tea cup. This enriches and brings new impetus – also for their own work. At HAINBUCH the next generation is encouraged and challenged; from day one. No wonder the ratio of those who want to stay is decidedly high. Many remain for a term of employment that is longer than average.



Sandra Casella

» Reliance, responsibility, business etiquette, reporting – all this you learn at HAINBUCH, and not just in theory. From the very first day us trainees are integrated in the active business, and above all: We are taken seriously. A cool feeling. «

Sandra Casella has just finished her training as industrial business clerk at HAINBUCH and is now working in the Accounting Department.

Nicole Arndt

» The We feeling and the well-being factor are very important at HAINBUCH. Here you are never left alone, even when preparing for the tests, this is really very good. This is not the case at every company. Nor is the fact that you get the chance to look beyond the rim of the tea cup. «

Nicole Arndt is also an industrial business clerk who recently completed her training. She has been working in the HAINBUCH sales team since her training was concluded.



Florian Geisler

» cultus has left lasting impressions and has ensured many aha effects. Super. At HAINBUCH a lot of things are simply different than they are at other companies. At the end of the training you have seen virtually every department, and consequently you can also optimally understand the operational processes. «

Florian Geisler has also bid farewell to life as a trainee. He is also an industrial business clerk, just finished and he has been working in the Export Team since mid of July.

Permanent learning

»ERFAHRUNGSREICH«

»ERFAHRUNGSREICH« MEANS »RICH IN EXPERIENCE«. AND THIS IS LEARNING À LA HAINBUCH: INDIVIDUAL, NEED-ORIENTED, AND DECIDEDLY PRACTICAL. A GENUINE ENRICHMENT.

What you really want to learn, you also learn more easily. What could be more effective than to let the employees learn what they want to learn? But what do they want? »ErfahrungsReich« finds out. At a kick-off workshop the participants first work through the image of the ideal employee, from this they determine the qualification requirements, then prioritize these together. The activity, the practicality, and learning from each other and with each other are the outstanding characteristics of »ErfahrungsReich«. After the kick-off event this is as different as the participants

themselves: Reading books and presenting them can be on the continuing education program, consulting with internal or external trainers or also the exchange with other departments.

By the way, no managers are at the kick-off workshop, but rather a »neutral« moderator. Naturally this ensures a significantly less constrained atmosphere and thus better results. An exciting story, wholly in the spirit of the corporate identity, and with sustainable growth potential.



Over rough and smooth terrain in the Black Forest [left] and in the Satteldorf plant [right].



Day and night on the bike: The 24-hour bike race on the Nürburgring demanded a lot from the HAINBUCH bike team.

Always active!

HAINBUCH SPORTS CLUB »SPANNTREFF«

24-h bike race on the Nürburgring, hiking in the Black Forest or an outing to the Satteldorf production location with a visit to an organic farm, hiking and a hearty snack to conclude – sports club »SV Spanntreff« offers its members any number of fields for athletic action. Depending on the season there are the standards such as gymnastics, soccer, volleyball, and tennis, also appropriate outdoor activities such as mountain biking, inline skating, beach volleyball, or cross-country skiing. By the way, the club is not just for HAINBUCH employees, anyone can participate.



Running for fundraising: The »Marbach Miles«. With HAINBUCH as sponsor and active HAINBUCH runners.