



CENTREX duo

Centering unit for reliable processes

- Extremely high repeatability [≤ 0.003 mm]
- Simple handling
- Can be flexibly integrated into your own designs, even in the smallest installation space
- Installed in thousands of designs
- Impervious to contamination and chips
- Unbeatable price



Product description

Positioning repeatability of the manufacturing parts and high process reliability are the top priorities in production. With the CENTREX duo centering unit you can easily set up your components. Thus, tedious and time-consuming adjustment for component machining is now a thing of the past. CENTREX duo can be used universally for a wide range of applications.

Key advantages

- Centering element for high-precision positioning of two components
- Extremely high repeatability [≤ 0.003 mm]
- Can be flexibly integrated into your own designs, even in the smallest installation space
- Impervious to contamination and chips through vulcanization

User example: Pallet system



CENTREX duo

- Extremely easy handling
- No tilting when joining and no wear

Off-the-shelf centering pin

- Difficult handling, only parallel joining possible
- Tilted and worn out

CENTREX duo in detail

Designation	
1 Positioning taper	<p>9 ——— 9 8 ——— 8 7 ——— 7 6 ——— 6 5 ——— 5 2 ——— 2 3 ——— 3 4 ——— 4</p>
2 Positioning bushing	
3 Placement diameter for easy assembly	
4 Lead-in chamfer for easy assembly	
5 Rubber for positioning the precision balls	
6 Precision balls as centering element	
7 Disassembling thread	
8 Neck for plane-parallel installation of the positioning taper	
9 Lead-in chamfer for easy assembly	

Installation

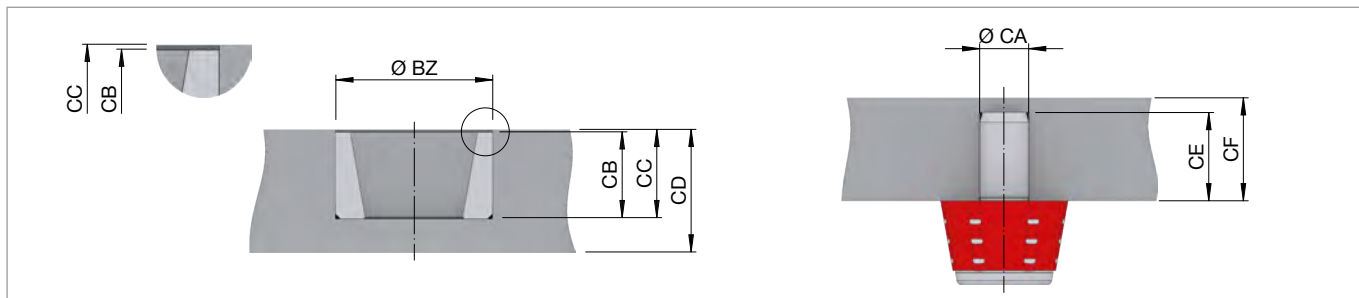

Description	Positioning bushing		Positioning taper	
	1	3	1	3
Repeatability ≤ [mm]	0,003			
Weight [kg]	0.01	0.05	0.01	0.04
Bore bush Ø [mm]	BZ Ø 16 H7	Ø 32 H7		
Bushing height [mm]	CB 8.5	17.5		
Bore depth	CC 9 [+0.0 -0.1]	18 [+0.0 -0.1]		
Min. plate thickness [mm]	CD 12.5	25		
Bolt Ø [mm]	CA		Ø 6 H7	Ø 10 H7
Bolt length [mm]	CE		9	18
Min. plate thickness [mm]	CF		12	21
In stock	✓	✓	✓	✓
Part no.	2096/0009	2096/0008	2097/0011	2097/0010

To achieve the best-possible alignment of the two components, the CENTREX duo elements must be positioned as far away from each other as possible.

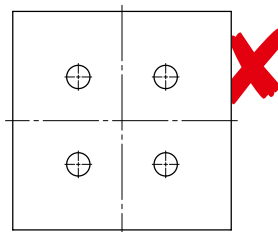
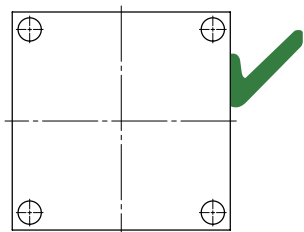

Installation dimensions – positioning bushing

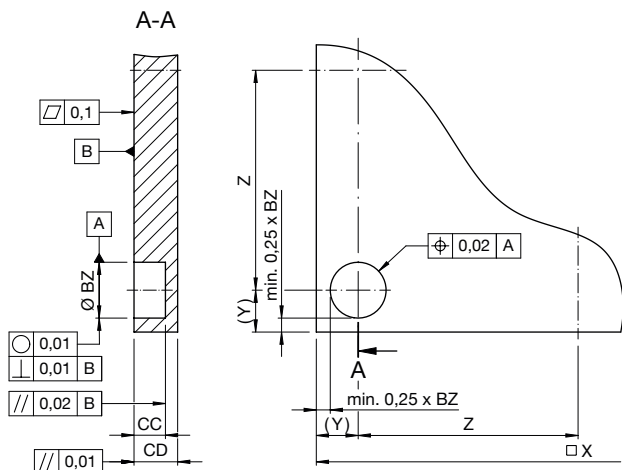

Installation dimensions – positioning taper

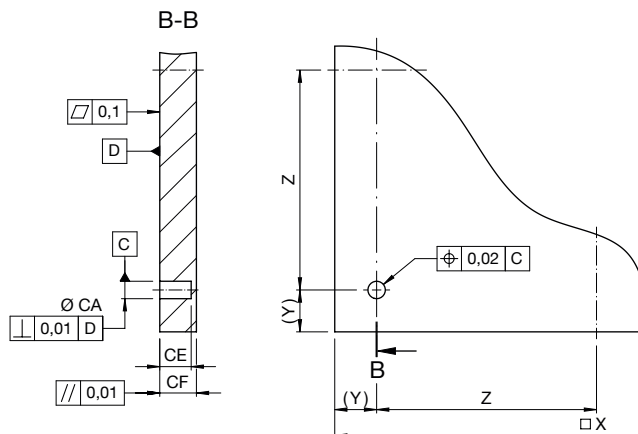

Minimum pull-back effect due to the pull-in mechanism [e.g. screw connection]

Size	1		3	
Quantity CENTREX duo	1	4	1	4
Minimum pull-back force [kN]	1.5	6	2.5	10

The pull-back force due to the pull-in mechanism must be absorbed by the components, as the CENTREX duo elements are only suitable for centering and not for absorbing force. When applying the minimum pull-back effect, a friction lock occurs between the two components, whereby the CENTREX duo elements remain free of transverse forces.

- The maximum operating temperature is 80 °C
- Normally the positioning bushing is pressed into the base plate and the positioning taper is pressed into the change plate or the component
- The maximum axis center offset of positioning taper and positioning bushing must not be > 3 mm

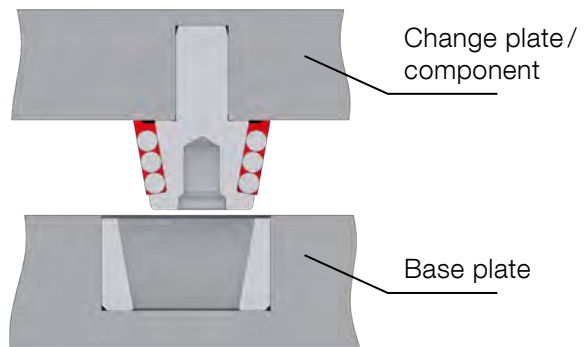

Particularities for horizontal installation

The same installation dimensions apply for vertical installation. Since the components absorb the transverse force in clamped status, the CENTREX duos are free of transverse force. When changing pallets or joining components CENTREX duo elements must only be subjected to the following transverse forces:

Size	1		3	
Quantity CENTREX duo	1	4	1	4
Transverse force Fmax [N]	35		250	

Joining

Clamped status

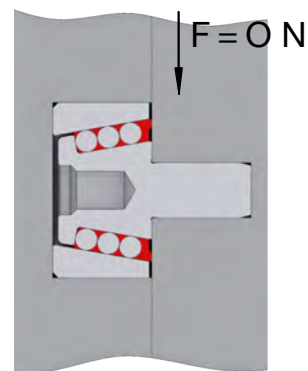
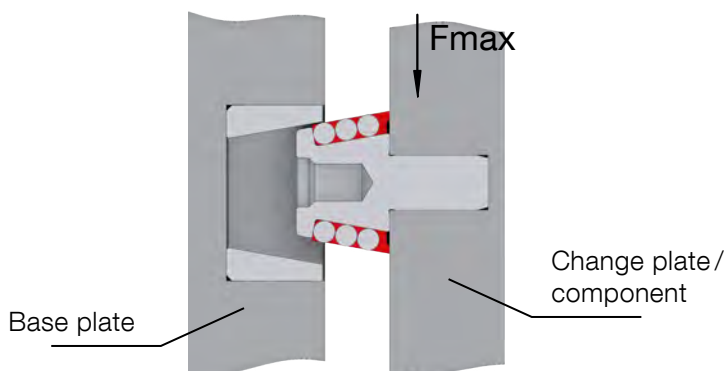

Application examples

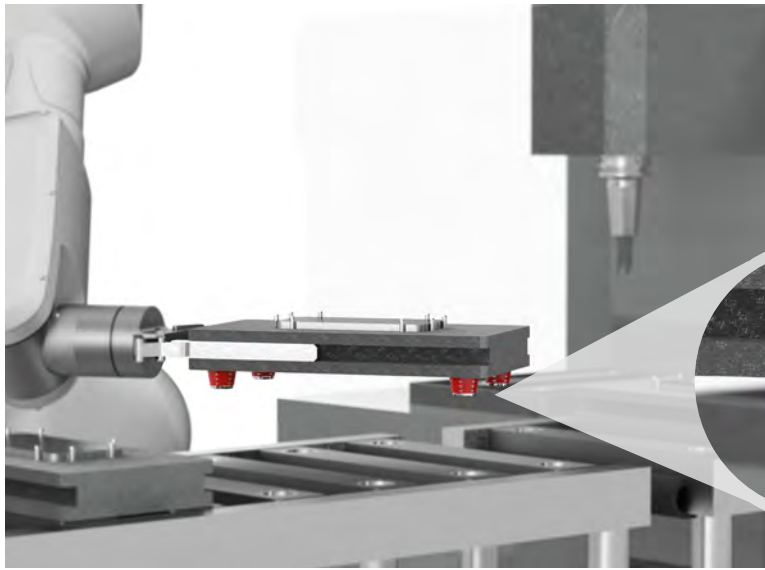

Workpiece carriers

CENTREX duo as a positioning element of workpiece carriers for multiple manufacturing and assembly stations [e.g. smartphone production].

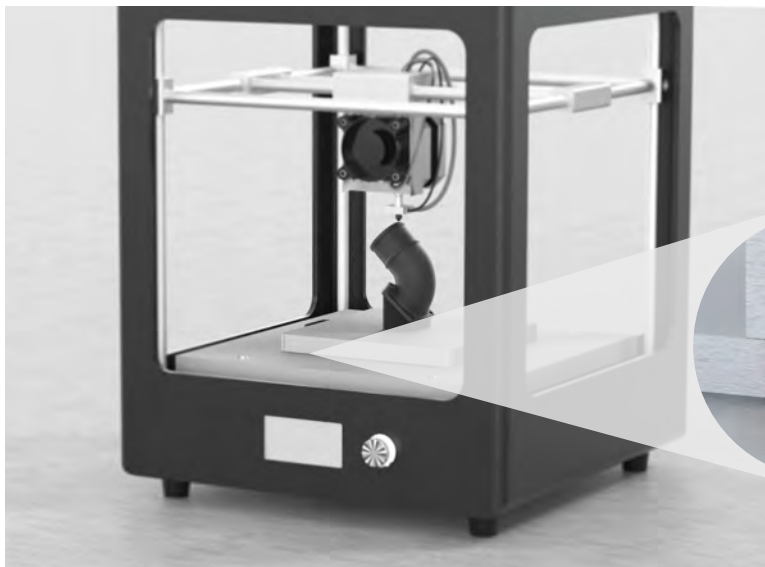

Additive manufacturing

CENTREX duo as positioning element of the base plate in a 3D printer.

Additional information on use

- Temperature differentials of up to 30 K can be compensated
- The rubber does not become brittle; it is impervious to contamination or chips
- Pressed-in chips do not harm the system
- Cooling lubricants that contain ester or polar additives should not be used
- An undercut should be introduced for pulling off to replace the positioning bushing

Function description

- ① When joining two plates or components equipped with CENTREX duo, the positioning taper is pressed into the positioning bushing.
- ② In this process the balls of the positioning taper rest lightly on the positioning bushing; the two plates do not yet rest flat against each other.
- ③ When applying the pull-back force [F] the precision balls press into the taper surface and the support surfaces of the two plates are aligned to each other. In this process the shell surfaces of the taper bushing and of the taper mandrel are deformed elastically in the area of the precision balls. The shell surfaces of the two tapers have the same hardness overall. Due to the prevailing equilibrium of forces the positioning taper always strives to be aligned in the center of the taper bushing. Through this centering the component is always precisely positioned in the axis with high repeatability.

