

Operating instructions

[incl. installation manual]

SPANNTOP mini pull-back

Size 125 - 160

EN

Translation of the original operating instructions

Contents

1	General.....	7
1.1	Information about this manual.....	7
1.2	Key to symbols.....	7
1.3	Definition of terms	8
1.3.1	Release setting.....	8
1.3.2	Complete clamping reserve	8
1.4	Limitation of liability	9
1.5	Copyright.....	9
1.6	Scope of delivery	9
1.7	Spare parts and accessories.....	10
1.8	Warranty terms	10
2	Safety	11
2.1	Responsibility of the operator.....	11
2.2	Personnel requirements	12
2.3	Intended use	14
2.4	Personal protective equipment.....	15
2.5	Particular hazards	17
2.6	CFRP products	18
2.7	Other safety instructions	18
2.8	Screws	20
2.9	Functionality.....	21
2.10	Environmental protection	21
3	Technical data	22
3.1	General information.....	22
3.2	Performance values	22
3.3	Balancing quality	23
3.4	Speed.....	23
3.5	Clamping force diagram	24
3.5.1	Size 125	24
3.5.2	Size 160	25
3.6	Operating conditions	25
3.7	Type designation.....	25
4	Layout and function	26
4.1	Overview and brief description.....	26
4.2	Accessories required.....	27
4.2.1	Spindle flange.....	27
4.2.2	Drawtube adapter	27
4.2.3	Clamping head	27
4.2.4	Workpiece end-stop.....	27
4.3	Optional accessories.....	27
4.3.1	MANDO Adapt.....	27

4.4	Special aids.....	28
4.4.1	Pneumatic changing fixture	28
4.4.2	Assembly key	28
5	Use and limits of use	29
5.1	Use.....	29
5.2	Limits of use	29
5.2.1	Nomenclature	29
5.2.2	First limit [workpiece length]	32
5.2.3	Second limit [workpiece mass]	32
5.2.4	Third limit [clamping length].....	33
5.2.5	Fourth limit [forces].....	33
5.2.6	Sample calculation	46
6	Transport, packaging, storage.....	50
6.1	Safety, transport, packaging, storage	50
6.2	Symbols on the packaging	51
6.3	Transport inspection.....	51
6.4	Unpacking and internal transportation.....	52
6.5	Packaging	52
6.6	Storage	53
6.7	Preservation.....	53
6.8	Return to storage	53
7	Installation	54
7.1	Installation safety	54
7.2	Preliminary remarks	56
7.3	Screw tightening torques.....	56
7.4	Preparation of the machine for installation	58
7.5	Installation of the product	59
7.5.1	Compatibility check.....	59
7.5.2	Preparation of the product	60
7.5.3	Installation of the drawtube adapter.....	62
7.5.4	Installation of a spindle flange that cannot be aligned	63
7.5.5	Installation of a spindle flange that can be aligned	65
7.5.6	Installation of the functional unit of an alignable clamping device	67
7.5.7	Installation of the functional unit of a non-alignable clamping device	70
7.6	Installation of the clamping element.....	74
7.7	Installation of the changing parts	76
7.7.1	Installation of the variant, screwed directly	77
7.7.2	Installation of the variant x-times with axial screw connection.....	77
7.7.3	Installation of the variant x-times with bayonet axial screw connection	79
7.7.4	Installation of the central variant with axial screw connection.....	80
7.7.5	Installation of the radially clamped variant.....	82

	7.8	Aligning the clamping device with the test specimen	84
8		Commissioning	85
	8.1	Commissioning safety	85
	8.2	Checking the total stroke	87
	8.3	Tests	88
	8.4	Workpiece	89
	8.5	Procedure after a collision	89
9		Activities after end of production	90
10		Removal	91
	10.1	Safe removal	91
	10.2	Preparing the machine for removal	93
	10.3	Removal of the changing parts	93
	10.3.1	Removal of the variant with direct screw connection	94
	10.3.2	Removal of the variant x-times with axial screw connection	95
	10.3.3	Removal of the variant x-times with axial screw connection bayonet	96
	10.3.4	Removal of the central variant with axial screw connection	97
	10.3.5	Removal of the radially clamped variant	98
	10.4	Removal of the clamping element	99
	10.5	Removal of the product	101
	10.5.1	Removal of the functional unit	101
	10.5.2	Removal of the spindle flange	104
	10.5.3	Removal of the drawtube adapter	105
11		Maintenance	106
	11.1	Maintenance safety	106
	11.2	Maintenance schedule	106
	11.3	Cleaning	108
	11.4	Visual inspection	110
	11.5	Lubricating the product	110
	11.6	Use of lubricants	112
12		Disposal	113
13		Faults	114
	13.1	Procedure with faults	114
	13.2	Fault table	115
	13.3	Commissioning after a fault has been remedied	116
14		Annex	117
	14.1	Contact	117
	14.2	Manufacturer certification	117

Directory of tables

Table 1:	Technical data	22
Table 2:	Operating conditions	25
Table 3:	Nomenclature application limits.....	31
Table 4:	Maximum workpiece mass	33
Table 5:	Scatter widths of clamping force.....	36
Table 6:	Contact forms / scenarios.....	36
Table 7:	Contact factor	37
Table 8:	Specific cutting forces	38
Table 9:	Friction coefficient for steel workpieces	39
Table 10:	Clamping head mass and distance of mass center of gravity of clamping head segments to the rotational axis.....	40
Table 11:	Maximum permitted tailstock force	42
Table 12:	Maximum permitted cutting force	43
Table 13:	Maximum permitted transverse force	44
Table 14:	Maximum permitted torque due to transverse force	45
Table 15:	Screw tightening torques, metric control threads.....	57
Table 16:	Screw tightening torques for aluminum components.....	57
Table 17:	Screw tightening torques for screw plugs	58
Table 18:	Maintenance table	107
Table 19:	Selection of lubricants	112
Table 20:	Fault table.....	116

1 General

1.1 Information about this manual

This manual enables you to work safely and efficiently with the product.

This manual is part of the product and must be kept in a location directly beside the product that is accessible to the personnel at all times. The personnel must have read this manual carefully and understood its contents before starting any work. The basic requirement for safe work is compliance with all stipulated safety notices and work-related instructions in this manual.

If the product is passed onto a third party, this manual must accompany it.

Illustrations in this manual are there to facilitate a basic understanding, and may differ from the actual design configuration of the product.



WARNING

Serious injuries caused by individual products or by inappropriate combinations of them!

- Read and pay attention to all operating instructions for individual products and combinations of them.

1.2 Key to symbols

Safety instructions in this manual are designated by symbols. The safety notices are invoked by signal words that express the level of hazard involved.

Always comply with safety notices and exercise caution to avoid accidents, injury to people and damage to materials.

Safety notices



DANGER

... indicates an immediate and hazardous situation that can lead to death or serious injury if not avoided.



WARNING

... indicates a potentially hazardous situation that can lead to death or serious injury if not avoided.



CAUTION

... indicates a potentially hazardous situation that can lead to moderate or slight injuries if not avoided.



NOTE

... indicates a potentially hazardous situation that can lead to damage to materials if not avoided.

Tips and recommendations



INFORMATION

... highlights useful tips and recommendations as well as information for efficient and problem-free operation.



... refers to other documents relating to personal and general safety.

Warning symbols may appear on the product or its components.

Always pay attention to warning symbols, and exercise caution to avoid accidents, injury to people and damage to materials.



... warns of stored energy [for example involving springs].



... warns of hand injuries.



... draws attention to the fact that the operating instructions of the product must be read.

1.3 Definition of terms

1.3.1 Release setting

Release setting means that the clamping device is released. If the clamping device is released, this also releases the workpiece.

1.3.2 Complete clamping reserve

Complete clamping reserve means that the clamping device is clamped without a workpiece. The complete stroke has been used up, which means that the clamping device is therefore at the limit position for clamping reserve.

1.4 Limitation of liability

All details and notices in this manual were compiled with due reference to applicable standards and specifications, state-of-the-art technology and our many years of expertise and experience.

The manufacturer accepts no liability for damage arising from any of the following:

- Non-compliance with this manual
- Unintended use
- Use of untrained personnel
- Autonomous conversion work
- Technical modifications
- Use of non-approved spare parts
- Use of non-approved accessories
- Installation and use of clamping elements not made by the manufacturer

Subject to any commitments agreed to in the supplier contract, the General Terms & Conditions of Business and the delivery terms of the manufacturer and all legislative stipulations valid at the time of conclusion of this contract.

1.5 Copyright

This manual is protected by copyright, and are only intended for internal use.

The dissemination of this manual to third parties, reproductions in any shape or form - even in part - as well as commercial use and/or communication of their contents are prohibited for anything other than internal use, except with the written consent of the manufacturer.

Infringements oblige the offending party to pay compensation. Without restriction on further claims.

1.6 Scope of delivery

The scope of delivery of this product includes:

- SPANNTOP mini
- The operating instructions

Additionally needed and included as optional items in the scope of delivery:

- Spindle flange
- Drawtube adapter
- Clamping head
- Workpiece end-stop
- Changing fixture
- Assembly tool

1.7 Spare parts and accessories



WARNING

Serious injuries can be caused by incorrect or defective spare parts!

- Always use genuine spare parts made by the original manufacturer.



WARNING

Serious injuries can be caused by incorrect or defective clamping elements!

- Always use genuine clamping elements made by the original manufacturer.



NOTE

Damage, malfunctions or total failure of the product or the machine tool caused by an incorrect or defective spare parts!

- Always use genuine spare parts made by the original manufacturer.



NOTE

Damage, malfunctions or total failure of the product or the machine tool caused by an incorrect or defective clamping elements!

- Always use genuine clamping elements made by the original manufacturer.

Spare parts and accessories can be sourced from contract dealers or directly from the manufacturer [see »Contact« chapter].

Without exception, wearing parts and components in contact with the workpiece are not covered by warranty.

1.8 Warranty terms

The warranty terms are included in the manufacturer's General Terms & Conditions of Business.

2 Safety

This section provides an overview of all the important safety aspects for optimum protection of personnel, and for safe and problem-free operation.

2.1 Responsibility of the operator

The product is used in the industrial sector. The operator of the product is therefore governed by the provisions of Health & Safety at Work legislation.

As well as the safety notices in this manual, the area of use of the product must also comply with locally applicable safety, accident prevention and environmental protection specifications as well as those in the manual for the machine tool.

No modifications must be made to the product. The operator is wholly and solely responsible for any resultant personal injury and/or damage to materials.

Excepted from this are changing parts that HAINBUCH approved explicitly for autonomous machining, but specified limits must never be exceeded.



DANGER

Serious injuries caused by parts being ejected centrifugally due to a drop in actuating force / supply pressure!

- On the machine, ensure that the actuating force / the supply pressure do not drop while the product is in use.
- If no precautions have been taken on the machine to maintain the actuating force / the supply pressure, it is prohibited to use this product on the machine.
- Pay attention to the operating instructions for the machine tool.

In particular, note that end-stop requests by the machine tool must be set on the product involved.



DANGER

Serious injuries caused by parts being ejected centrifugally after defective setting of the machine!

- Set up the end-stop requests by the machine tool on the product involved.
- On a regular basis, check the end-stop requests of the machine tool [see »Maintenance schedule« chapter].
- If the limit stops are not reached, the product must not be used any more.

2.2 Personnel requirements



WARNING

Serious injuries caused by incorrect handling of the product by insufficiently skilled or trained personnel!

- All activities must be performed by skilled staff from the relevant specialist field.



WARNING

Serious injuries caused by unauthorized presence of unauthorized personnel in the working area!

- Keep unauthorized people away from the working area.
- If in doubt, speak to people and direct them to leave the working area.
- Interrupt work until unauthorized people have left the working area.



NOTE

Serious damage to materials caused by incorrect handling of the product by insufficiently skilled or trained personnel!

- All activities must be performed by skilled staff from the relevant specialist field.

This manual name the following skills sets required for various different areas of activity:

Skilled specialist

Skilled specialists, due to their professional training, knowledge and experience and awareness of applicable provisions, are capable of carrying out the work entrusted to them and independently to identify and avoid potential hazards.

Hydraulics specialist

Hydraulics specialists are trained in the specific task profile for which they are employed, and are familiar with the relevant standards and legislative provisions.

Due to their vocational training and experience, hydraulics specialists can work on hydraulic systems and can independently identify and avoid potential hazards.

Pneumatics specialist

Pneumatics specialists are trained in the specific task profile for which they are employed, and are familiar with the relevant standards and legislative provisions.

Due to their vocational training and experience, pneumatics specialists can work on pneumatic systems and can independently identify and avoid potential hazards.

Electricians

Electricians are trained in the specific task profile for which they are employed, and are familiar with the relevant standards and legislative provisions.

Due to their vocational training and experience, electricians can work on electrical systems and can independently identify and avoid potential hazards.

Trainees

Trainees can only work on the machine under the supervision and direction of staff skilled in the relevant specialist field.

The only people admitted as personnel are those who can reasonably be expected to carry out their work to a reliable standard. People whose response capabilities are impaired, for example by drugs, alcohol or medication, are prohibited.

For the selection of personnel, pay attention to the stipulations applicable at the place of work governing age and specific vocational requirements.

2.3 Intended use

The product is only intended for installation in a CE-compliant machine tool with a separating set of guards.

The product is only intended for the type of use described in this manual [see »Use« chapter]. Furthermore, an extended form of use can be agreed contractually between manufacturer and operator.

Only skilled staff from the appropriate specialist fields may install, operate, maintain and clean the product [see »Personnel requirements« chapter].

Never exceed the technical values stipulated for the product [see »General information« and »Operating conditions« chapters].

Furthermore, never exceed the limits for use of the product [see »Limits of use« chapter].

Maintain the product at regular intervals [see »Maintenance schedule« chapter].

When used for its intended purpose, the operational safety of the product is assured, subject to compliance with relevant safety stipulations, to the full extent foreseeable.

Intended use also includes compliance with all stipulations in this manual.

Any form of use beyond the scope of intended use, or other forms of use of the product, is considered as misuse, and can lead to dangerous situations.



DANGER

Serious injuries caused by misuse of the product!

- Only in a CE-compliant machine tool with a separating set of guards.
- Only use for the type of use indicated [see »Use« chapter].
- Only skilled staff from the appropriate specialist fields may use the product [see »Personnel requirements« chapter].
- Never exceed the technical data indicated on the product [see »General information« and »Operating conditions« chapters].
- Never exceed the limits for use of the product [see »Limits of use« chapter].
- Maintain the product at regular intervals [see »Maintenance schedule« chapter].
- Only use with approved attachments and/or clamping elements.



DANGER

Serious injuries caused by parts being ejected centrifugally during commissioning without a workpiece!

- Never rotate the product without a workpiece installed.
- For commissioning, clamp an appropriate workpiece at every available clamping point.



NOTE

Damage to materials caused by incorrect use of the product!

- Only in a CE-compliant machine tool with a separating set of guards.
- Only use for the type of use indicated [see »Use« chapter].
- Only skilled staff from the appropriate specialist fields may use the product [see »Personnel requirements« chapter].
- Never exceed the technical data indicated on the product [see »General information« and »Operating conditions« chapters].
- Never exceed the limits for use of the product [see »Limits of use« chapter].
- Maintain the product at regular intervals [see »Maintenance schedule« chapter].
- Only use with approved attachments and/or clamping elements.

Claims of all kinds will be rejected that are due to unintended use.

Here are some examples of unintended use of the product

- If workpieces are not clamped properly.
- If people fail to observe the safety stipulations when working on the product, and failing to use additional protective equipment, for example to machine clamped workpieces.
- If the product is used on machines, workpieces and/or changing parts for which it is not intended.

2.4 Personal protective equipment

During work, it is essential to wear personal protective equipment to minimize the health hazards.

Always wear the required personal protective equipment when working on any given job.

Always pay attention to any notices about personal protective equipment displayed in the working area.

Always wear



Additional personal protective equipment



When working, always wear the following items:

Workplace clothing

Workplace clothing should be close-fitting, with low tear-resistance, narrow cuffs and no protruding parts. It serves primarily to protect the wearer from coming into contact with moving machine parts. Do not wear rings, chains or other jewelry.

Safety footwear

To protect the wearer from any heavy items that may fall, and from losing their footing on slippery ground.

Protective goggles

To protect the eyes from projectile parts and liquid splashes.

Hair net

To protect long hair from getting snagged in rotating parts on the machine tool.

When carrying out certain work, additional personal protective equipment is required. Separate reference is made to this in the individual chapters of this manual. The following section explains these additional items of personal protective equipment:

Protective gloves

To protect the hands from friction, chafing, stabbing or deeper injuries and from contact with hot surfaces.

Hard hat

To protect against falling and projectile parts and materials.

2.5 Particular hazards

The following section names residual risks resulting from the installation of the product in a machine tool. In all cases, the residual risks detected during a risk assessment of the machine tool need to be named by the operator.

Pay attention to the safety instructions named here, as well as the warning notices in other chapters of these operating instructions to reduce the risk of health hazards and to prevent dangerous situations.

Moving parts



WARNING

Serious injuries caused by touching rotating and/or moving parts!

- Do not open guards while the system is operating.
- During operation, do not reach for rotating and/or moving parts.
- Pay attention to the gap dimensions of moving parts.
- Before opening the guards, ensure that none of the parts are moving any more.

Stroke



WARNING

Serious crushing injuries caused by the stroke of the product!

- Never reach into an area where moving parts are operating.
- Prevent accidental initiation of the clamping process [for example due to an installation error with the power supply or a programming error].

Insufficient workpiece clamping



DANGER

Serious injuries caused by parts being ejected centrifugally if level of workpiece clamping is insufficient!

- Workpiece blanks must not be outside the clamping width diameter.
- Clamping of the workpiece must not be outside the defined limits [see »Limits of use« chapter].
- Do not exceed the maximum performance values [see »General information« chapter].

Insufficient workpiece clamping



WARNING

Serious injuries caused by breakage of individual components of the product when actuating force is too high!

- Check actuating force on a regular basis and adjust if necessary.

Sharp-edged parts



WARNING

Serious cut injuries caused by sharp-edged parts and burrs!

- All installation of individual parts must be performed by skilled staff from the relevant specialist field.
- Also wear the following items of personal protective equipment, in addition to the basic equipment:



2.6 CFRP products

CFRP products are used on highly dynamic machine tools to reduce the total inertia torque.

CFRP products are designated on the product nomenclature with the suffix CFK.

Pay attention to the following with carbon components on the CFRP product:



WARNING

Serious injuries caused by loss of endurance strength of the product!

- Check product for visible signs of damage, or clear indications of wear on the carbon components!
- If damage is discovered, do not work on it until after discussion with the manufacturer.



INFORMATION

On CFK products, the spindle flange is always made of aluminum.

Pay attention to the deviating tightening torques for aluminum components [see »Screw tightening torques« chapter].

2.7 Other safety instructions



DANGER

Serious injuries caused by workpieces being ejected centrifugally when clamping unit is released while still rotating!

- Never release the clamping of the workpiece while it is still rotating.



WARNING

Serious head injuries caused by bending into the working area of the machine!

- Only ever bend into the working area of the machine if there are no cutting tools or sharp objects in it, or if these are covered.
- Never move body parts under parts in the working area of the machine with the potential to drop down.



WARNING

Serious injuries caused by snagging body parts on the rotating machine spindle!

- Never reach into the product while the machine spindle is still rotating.
- Before working on the product, ensure that the machine spindle is unable to start up.



WARNING

Serious injuries caused by reaching into slots and bores!

- Never reach into slots or bores.



WARNING

Serious injuries caused by workpieces dropping or the clamping unit getting released!

- Only unclamp the workpiece if it is protected against falling.



WARNING

Serious injuries caused by the use of damaged products or by their components and accessories!

- Check products or their components and accessories on a regular basis for visible signs of damage [see »Inspections« and »Cleaning« chapters].
- Use of damaged products, their damaged components and/or their damaged accessories is prohibited.
- Report damage to the operator immediately.
- Damaged components / accessories must be replaced with genuine spare parts / accessories made by the manufacturer.



CAUTION

Cut injuries caused by sharp edges and burrs resulting from wear and/or repeated rework!

- Remove sharp edges and burrs.
- If necessary, replace worn components with genuine parts made by the manufacturer.



NOTE

Serious damage to materials / the machine tool / the product caused by workpieces being ejected centrifugally if clamping is released while they are still rotating!

- Never release the clamping of the workpiece while it is still rotating.



NOTE

Damage to materials caused by untightening the wrong screws!

- Do not open the screws secured with sealing lacquer.

2.8 Screws



WARNING

Serious injuries caused by radially installed screws being ejected centrifugally if installed incorrectly / poor handling!

- Do not open the screws secured with sealing lacquer.
- Screws and threaded pins fitted radially to the product that were bonded with adhesive need to be secured again using a standard, medium-strength screw adhesive and tightened to the specified tightening torque [see nomenclature or the »Screw tightening torques« chapter]. Before reinstallation, clean and degrease the screw and internal thread.
- Radially mounted screws and threaded pins that were not bonded with sealing lacquer or an adhesive need to be tightened back down to the specified tightening torque [see nomenclature or the »Screw tightening torques« chapter].
- If in doubt, contact the manufacturer immediately to determine how best to proceed.

2.9 Functionality



WARNING

Serious injuries caused by severe contamination of the product!

- Always comply with the cleaning instructions and intervals [see »Cleaning« chapter].

2.10 Environmental protection



NOTE

Substantial damage to the environment can result from non-compliant handling or incorrect disposal of environmentally hazardous substances!

- If environmentally hazardous substances enter the environment accidentally, take immediate remedial action.
- If in doubt, notify the relevant municipal authorities about the incident.

The following environmentally hazardous substances are used:

Lubricants, auxiliary materials and operating fluids

Lubricants such as grease and oil can contain toxic substances. These must not enter the environment.

Dispose of environmentally hazardous substances properly [see »Disposal« chapter].

3 Technical data

3.1 General information

Size	Clamping range [mm]	Axial release stroke [mm]	Axial clamping reserve [mm]	Radial opening stroke in Ø [mm]	Radial reserve stroke in Ø [mm]	Total weight [kg]	Spindle flange weight [kg]	Functional unit weight [kg]	Dimensions [Ø x length] [mm]	Maximum speed [min^{-1}]	Axial clamping force $F_{ax.max.}$ [kN]	Radial clamping force $F_{rad.max.}$ [kN]	Balancing quality G in n planes
125	25-125	6.0	5.0	2.5	2.5	45.7-56.2	18.5-29.0	27.2	Ø 270.0-280.0 x 185.0-220.0	3200	70	165	4/1
160	27-160	3.0	3.0	1.3	1.5	57.0-72.0	21.0-36.0	36.0	Ø 301.0 x 189.0-250.0	3200	100	235	4/1

Table 1: Technical data

3.2 Performance values



NOTE

Material damage to the products use and/or to the machine tool caused by exceeding the maximum performance values!

- Do not exceed the maximum performance values [see »General information« chapter].
- On all products used, do not exceed the lowest of the maximum performance values.
- Only use product in machine tools with the same performance values.



INFORMATION

Details of maximum performance values can be found on each product.

If, due to abrasive wear, those performance values are no long legible, refer to the operating instructions.

The achievable actuation forces may vary as a result of the maintenance status [lubrication status and level of contamination] of the product [see »Maintenance schedule« chapter].

The achievable clamping forces resulting from actuating forces must be checked at regular intervals. For this, structural clamping force measurements must be performed.

The clamping force measured must be in the approved range [see »Clamping force diagram« chapter].

3.3 Balancing quality

The product is balanced before leaving the factory [balancing quality - see »General information« chapter].



DANGER

Serious injuries caused by parts being ejected centrifugally if products are not balanced correctly!

- Do not clamp rotationally symmetrical workpieces, or do so only after contacting the manufacturer.
- Never remove balancing screws and weights attached to the product.



NOTE

Material damage caused by machining with incorrectly balanced products!

- Do not clamp rotationally symmetrical workpieces, or do so only after contacting the manufacturer.
- Never remove balancing screws and weights attached to the product.

3.4 Speed

The product is authorized for rotational operation.

The maximum speed is written on the product [maximum speed, see »General information« chapter].



DANGER

Serious injuries caused by parts being ejected centrifugally due to a non-compliant combination of several products!

- From all of the maximum speeds indicated for the combined products, always remain at the lowest of those maximum speeds.



DANGER

Serious injuries caused by workpieces being ejected centrifugally after a loss of clamping power!

- Never rotate the product without a workpiece installed.
- When several clamping points are involved, clamp a suitable workpiece to each one.
- If necessary, adjust the machining forces.

3.5 Clamping force diagram

The clamping force diagram indicates the permitted range in which the radial clamping force is permitted to move in response to axial actuating force.

The clamping force diagram indicates the influences of friction and of the clamping diameter.



WARNING

Serious injuries caused by insufficient clamping force!

- The values measured for radial clamping force F_{rad} must be within the permitted range.
- If the values recorded are outside the permitted range, the product must be cleaned [see »Cleaning« chapter] and another clamping force test must be conducted.
- If the values recorded after cleaning is completed are outside the permitted range, you should contact the manufacturer.

3.5.1 Size 125

Sample scan:

At an axial actuation force F_{ax} of 50 kN, the radial clamping force F_{rad} is in a range of between 79 kN and 132 kN.

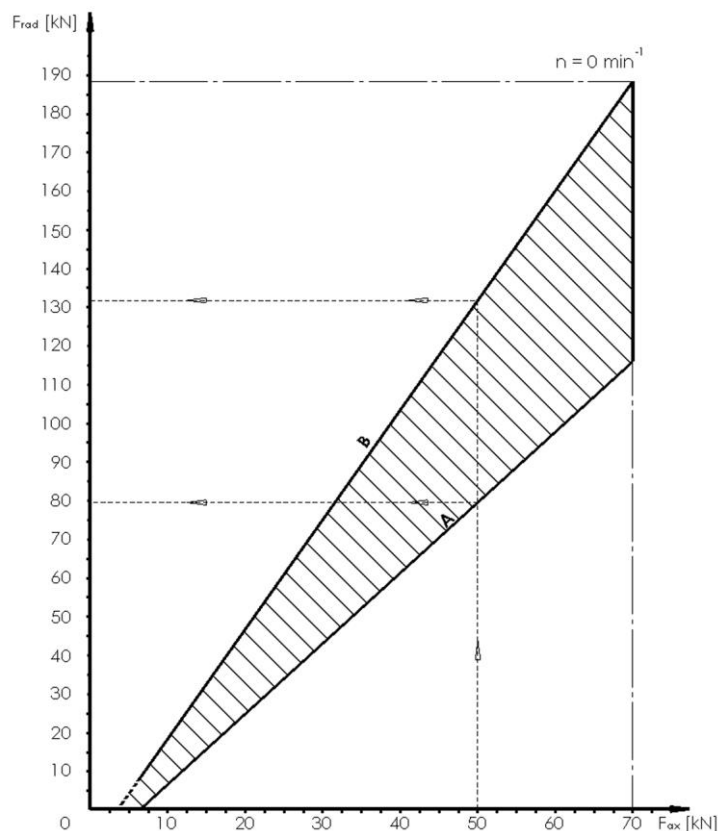

- A lower limit value
B upper limit value

3.5.2 Size 160

Scan sample:

At an axial actuation force F_{ax} of 60 kN, the radial clamping force F_{rad} is in a range of between 96 kN and 158 kN.

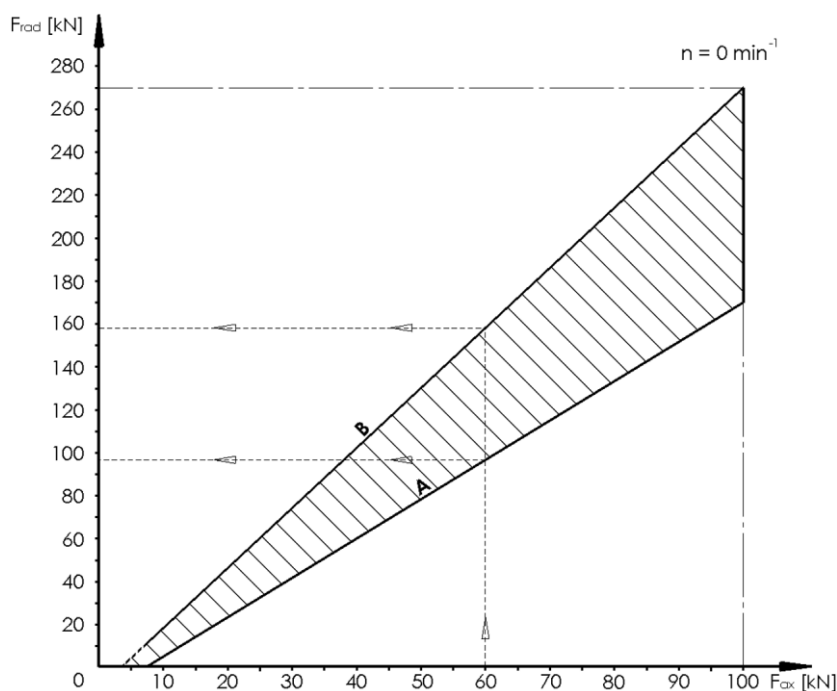

- A lower limit value
- B upper limit value

3.6 Operating conditions

Indication	Value	Unit
Ambient temperature range	15 - 65	°C
Workpiece temperature	≤ 80	°C
Humidity	≤ 80	%

Table 2: Operating conditions

3.7 Type designation

The type designation is on the product and it includes the following indications:

- Manufacturer
- Product designation
- ID number [marked with a # symbol]
- Build year
- Maximum speed n [min^{-1}]
- Maximum actuating force $F_{ax\ max}$ [kN]
- Maximum clamping force $F_{rad\ max}$ [kN]

4 Layout and function

4.1 Overview and brief description

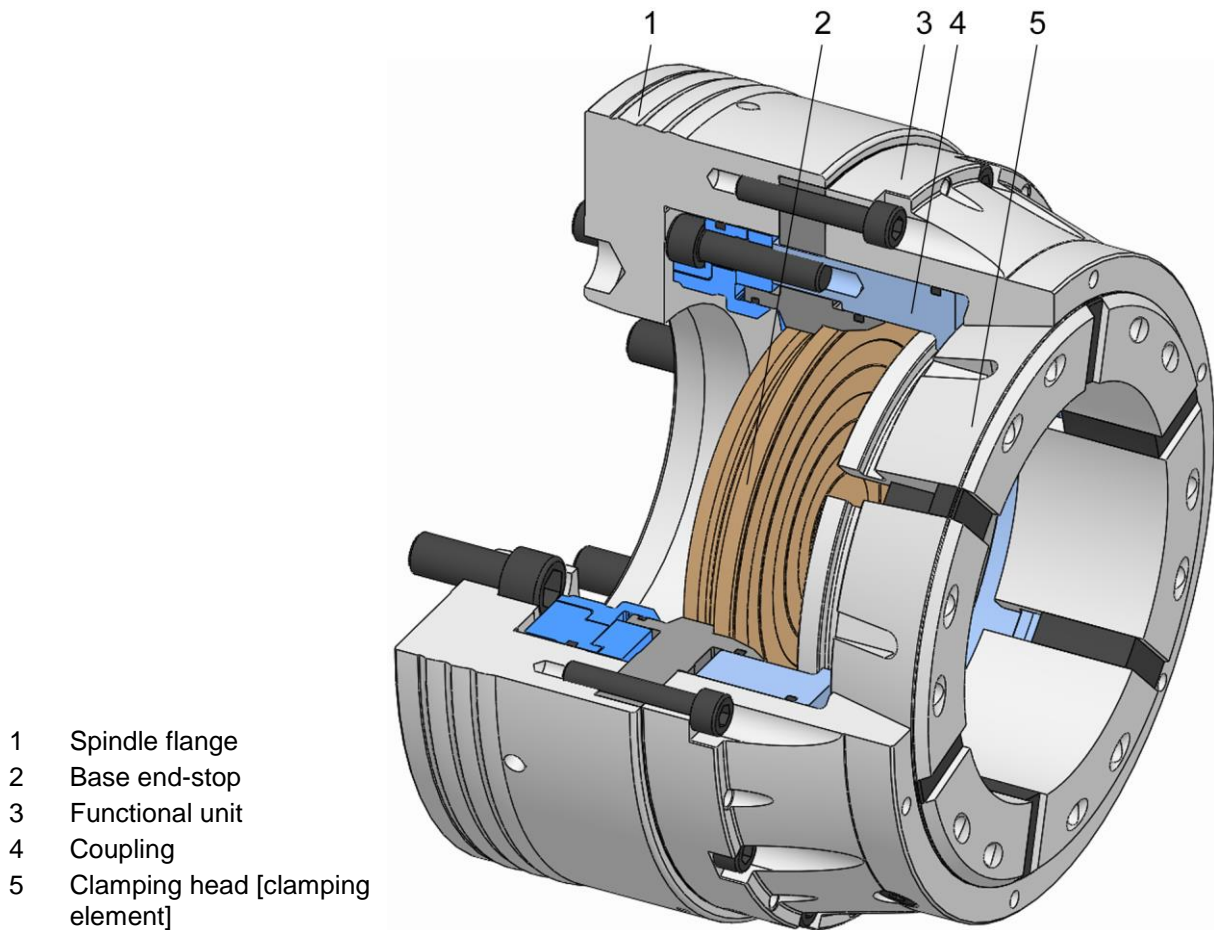

The clamping device can be used as a through-chuck for machining bar stock and also as an end-stop chuck.

The spindle flange is mounted on the machine spindle.

The clamping device is screwed to the drawtube on the machine tool through the drawtube adapter and is screwed to the spindle flange.

The clamping element was installed in the clamping device with an appropriate changing fixture and it clamps the workpiece being machined.

The workpiece end-stop can be screwed to the base end-stop, screwed on directly, or fitted as a front-mounted end-stop.

The clamping device functions on the pull-back principle.

When clamping, the clamping element performs an axial movement towards the workpiece end-stop.

The mobile coupling draws the clamping element into the stationary taper.

This draws the workpiece firmly up against the stationary workpiece end-stop.

This increases the rigid strength of this clamping configuration.

4.2 Accessories required

4.2.1 Spindle flange

The spindle flange helps to adapt the clamping device to suit the machine tool.

Depending on the scope of delivery, the spindle flange can either be supplied with the unit or provided by the customer.

4.2.2 Drawtube adapter

The drawtube adapter serves as a connector between the drawtube on the machine tool and the clamping device and, depending on the type of machine, can be configured in various forms.

4.2.3 Clamping head

The clamping head is there to support the workpiece being machined. It consists of hard steel and rubber segments connected by vulcanization.

Depending on workpiece requirements, various sizes of clamping head are available, also with different profiles and bores.

4.2.4 Workpiece end-stop

The workpiece end-stop is produced with an end-stop dimension that reflects customer wishes.

4.3 Optional accessories

The following optional accessories are available for different sizes of product.

4.3.1 MANDO Adapt

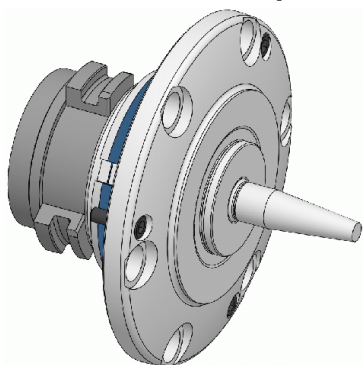

Through adaptation of the MANDO Adapt, internal clamping of the workpiece can be achieved.

4.4 Special aids

4.4.1 Pneumatic changing fixture

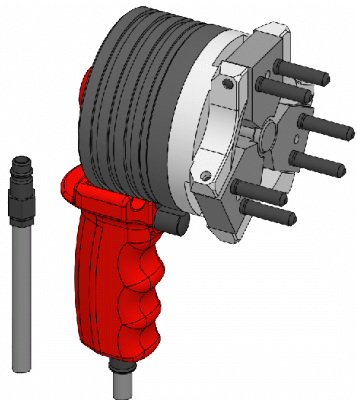

The pins on the changing fixture are installed in the changing bores in the clamping head. The changing fixture is actuated pneumatically. Depending on size, the changing fixture may be designed for single-handed or for two-handed actuation. The clamping head is clamped firmly in the changing fixture and can be installed in the mounted clamping device with the help of the changing fixture.

4.4.2 Assembly key

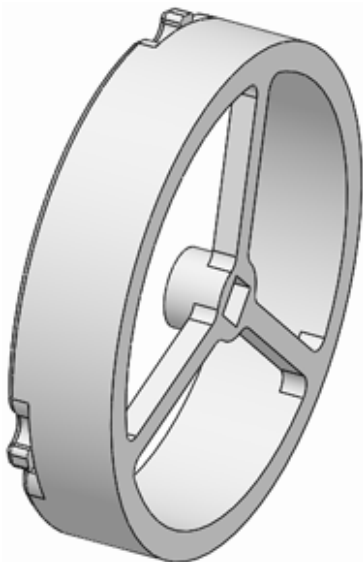

The assembly wrench is used to install and remove clamping devices.

5 Use and limits of use

5.1 Use

The product is a clamping device that may only be used to clamp a rotationally symmetrical workpiece to enable it to be machined.

As well as for its general field of application, this product was designed and developed for use, when necessary, in a specific and documented application [see clamping situation drawing or order confirmation].

Any other fields of application require the explicit approval of the manufacturer.

The clamping device can be used as an end-stop chuck. It can be attached directly to the base end-stop, or a workpiece end-stop can be mounted. For this, different connection points are provided on the clamping device.

The clamping device can be used as a through-chuck for machining bar stock. For this, the base end-stop must be removed. To avoid increased levels of contamination, there is the option of installing a swarf baffle ring.

With the help of suitable adaptation clamping devices from the manufacturer, the clamping device can rapidly be converted to suit a different clamp setting.

5.2 Limits of use

Limits are set on the operation of clamping head chucks in the area where workpieces are machined.

Specifically, before using these clamping head chucks, four separately independent limits need to be checked.

5.2.1 Nomenclature

Brief designation	Unit	Explanation
a_p	mm	Chip-cutting depth of turning operation
c	-	Contact factor
D	mm	Clamping diameter of clamping head
D_B	mm	Drill diameter
d_{sp}	mm	Clamping diameter
d_z	mm	Machining diameter of turning operation
f	mm	Feed / rotational movement of turning operation Feed / cutting-drilling operation

Brief designation	Unit	Explanation
F_{ax}	kN	Axial actuating force
F_B	N	Feed force of drilling operation
F_c	N	Cutting force of drilling operation
$F_{c max}$	N	Maximum cutting force of drilling operation
f_{fz}	N	Clamping force supplement for rotational compensation
F_G	N	Density of workpiece
f_n	mm	Feed / rotational movement of drilling operation
F_q	N	Transverse force
$F_{q max}$	N	Maximum permitted transverse force
F_{rad}	N	Radial clamping force
$F_{rad erf}$	N	Required radial clamping force
F_{sk}	N	Clamping force to prevent the workpiece getting levered out
F_{sz}	N	Clamping force to absorb the machining forces and torques during turning and/or drilling operations towards the chuck axis
F_t	kN	Tailstock force
$F_{t max}$	kN	Maximum tailstock force
k_c	$\frac{N}{mm^2}$	Specific cutting force
L	mm	Total chuck length
L_a	mm	Unclamping length
L_g	mm	Center of gravity distance between »Workpiece - clamping point«
L_q	mm	Distance, »radial bore machining - clamping point«
L_{sp}	mm	Clamping length
$L_{sp min}$	mm	The minimum clamping length required
$L_{sp v}$	mm	Total clamping length
L_w	mm	Workpiece length

Brief designation	Unit	Explanation
L_v	mm	Clamping head, front-end length
L_z	mm	Distance between »Machining point - clamping point« when turning
m	kg	Mass of the clamping head
M_B	Nmm	Drilling operation torque
M_q	Nm	Torque due to lateral force on the chuck axis
$M_{q\ max}$	Nm	Maximum torque due to lateral force on the chuck axis
m_w	kg	Workpiece mass
$m_{w\ max}$	kg	Maximum workpiece mass
n	min^{-1}	Speed
P	-	Key indicators for machining
r_s	m	Distance between mass center of gravity of clamping head segment and rotational axis of the chuck
S	-	Clamping force scatter width factor
μ_a	-	Friction coefficient in axial direction
μ_t	-	Friction coefficient in radial direction

Table 3: Nomenclature application limits

The graphic in the sketch below shows the forces and moments used in the following sample calculations:

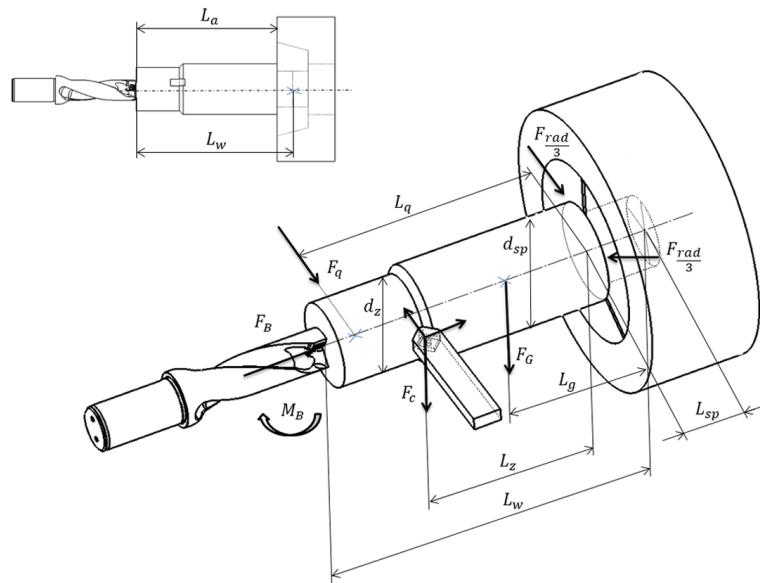

$$F_G [N] = m_w [kg] * 9.81 \left[\frac{m}{s^2} \right]$$

5.2.2 First limit [workpiece length]

The maximum unclamping length that can be machined without the aid of a back rest or a tailstock is 6 times the clamping diameter.

5.2.3 Second limit [workpiece mass]

The maximum workpiece mass depends on the size of the clamping head chuck [see Table 4].

[These values apply to individual workpieces. Special values apply to the machining of bar stock]

Size of the clamping head chuck	Maximum workpiece mass $m_w \max [kg]$	
	Horizontal application	Vertical application
32	12	18
42	20	30
52	28	40
65	40	60
80	50	75
100	65	100
125	80	120
140	100	150

Size of the clamping head chuck	Maximum workpiece mass $m_{w max} [kg]$	
	Horizontal application	Vertical application
160	120	180

Table 4: Maximum workpiece mass

5.2.4 Third limit [clamping length]

The clamping length must not be less than the minimum length required for clamping $L_{sp} \geq L_{sp min}$.

The front-end length of the clamping head L_v is not considered at all here.

With offset clamping bores [head bore], it may be necessary to take account of a relief groove in the clamping head when establishing the clamping length.

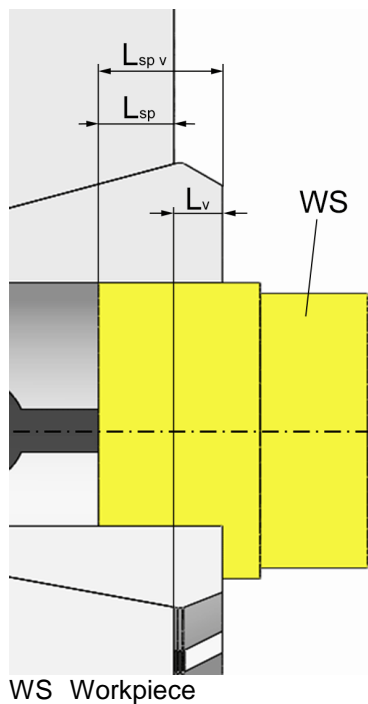

The clamping length is calculated as follows:

$$L_{sp} = L_{sp v} - L_v$$

$$L_{sp} \geq 0.08 * d_{sp} \text{ applies in all cases}$$

In addition, the following applies:

$L_{sp} \geq 2.8mm$ [when using clamping heads with a smooth clamping bore]

$L_{sp} \geq 13mm$ [when using clamping heads with longitudinal and transverse grooves]

When using clamping heads with a closed first tunnel, different details apply which may be even higher. Consult the manufacturer for these details.

$L_{sp} \geq 7mm$ [when using clamping heads with Z serrations]

$L_{sp} \geq 5mm$ [when using clamping heads with F serrations]

If HAINBUCH uses a different and shorter clamping length in this clamping situation drawing, this will have been checked against the specific parameters for this type of application and found to be sufficient.

5.2.5 Fourth limit [forces]

The following sample calculation shows how to quantify the forces that are exerted on the workpiece from an external source.

The aim here is to establish whether

1. the clamping force required to absorb external forces and torques can be applied by the clamping device.
2. the clamping device is free of visible or invisible damage caused by those external forces.

The forces and torques exerted on the clamping head and, ultimately, on the chuck are, for the most part,

- a) the machining forces and torques to be absorbed
- b) the density of the workpiece itself,
- c) the centrifugal forces caused by the weight of the clamping head
- d) where necessary, tailstock forces

Principles for the forces exerted externally



WARNING

Serious injuries caused by failure to comply with the principles that govern safe machining!

- Those principles must be maintained at all times to assure a safe machining process.

Pay attention to the following principles:

1. Principle $F_{rad} \geq F_{rad\ erf}$

AND

2. Principle $F_t \leq F_{t\ max}$

AND

3. Principle $F_c \leq F_{c\ max}$

[Relevant to turning and/or to axial drilling operations.]

AND

4. Principle $F_q \leq F_{q\ max}$

[Relevant to a radial drilling operation directed at the center and/or for the application of an equivalent load. If radial forces and the resultant torques are not directed at the center, due account of this can be taken by a quasi cutting force outside the center.]

AND

5. Principle $M_q \leq M_{q\ max}$

[Relevant to a radial drilling operation directed at the center and/or for the application of an equivalent load. If radial forces and the resultant torques are not directed at the center, due account of this can be taken by a quasi cutting force outside the center.]

With these principles, the assumption is that the clamping head chuck is used for a turning operation, or for an axial or radial drilling operation on the workpiece. There is no fundamental reason why the clamping head chuck cannot also be used for other machining tasks such as bypass milling or plunge-milling. In such cases, the owner must ensure that the forces and torques that occur are comparable to the equivalent permitted values for turning or drilling, to check the reliability of the application.

5.2.5.1 Further to Principle 1: $F_{rad} \geq F_{rad\ erf}$

Determining the required clamping force

The following equations are used to determine the required clamping force $F_{rad\ erf}$ at rotational speed.

These equations apply to longitudinal turning and to face turning operations. Drilling operations on the front end of workpieces can also be calculated. Superimposed, simultaneous machining operations, for example by several tools or turret heads can also be superimposed computationally. In other words, the required radial clamping forces for individual machining operations need to be added together.

However, it is rare for axial drilling and turning operations to be superimposed because their opposing directions of rotation usually preclude them from running simultaneously.

For computational purposes, the calculation should be based upon the point with the highest forces, that is the least favorable machining moment. If in doubt, several blade engagement situations need to be checked to record the least favorable one.

If radial drilling operations are being performed, the required radial clamping force $F_{rad\ erf}$, and especially a check of the transverse force introduced F_q and the resultant torque M_q play a central role.

Scatter widths of clamping force

The following table illustrates clamping force scatter width factor S .

The values for the scatter width factor apply if the system is being operated in accordance with the operating instructions, that is with regular maintenance and lubrication.

Provided that the radial clamping force is measured using appropriate measuring equipment before every start-up and continuously every 100 clamping operations, it is possible to work with the reduced and 'verified' clamping force scatter width factor shown here.

Size of the clamping head chuck	Radial clamping reserve in the diameter [mm]	Clamping force scatter width factor S	Clamping force scatter width factor S 'verified'
32	1.0	2.8*	1.3
42	1.0	2.0*	1.3
52	1.0	2.0*	1.3
65	1.0	1.6*	1.3
80	1.0	1.6*	1.3
100	1.5	1.45	1.3
125	2.5	1.45	1.3
140	1.5	1.45	1.3
160	1.5	1.45	1.3

* If as a consequence of dimensionally accurate workpieces, only 50% of the radial clamping reserve of the clamping head chuck is used up, the clamping force scatter width factor can be reduced by factor 0.85 [example: Size 52: $S = 2.0 * 0.85 = 1.7$].

Table 5: Scatter widths of clamping force

Contact factor

Consult the following tables for the contact factor, depending on the form of contact or the contact scenario.

Interference fit	Saddle fit	Edge fit
The clamping diameter of the clamping head matches the clamping diameter of the workpiece.	The clamping diameter of the clamping head is greater than the clamping diameter of the workpiece.	The clamping diameter of the clamping head is less than the clamping diameter of the workpiece.

WS Workpiece

SP Clamping element

Table 6: Contact forms / scenarios

Contact factor c	Machining conditions	Contact form	
		Interference fit and saddle fit	Edge fit
Smooth clamping head	Dry	1.1	1.0
	Wet* / MMS**	1.3	1.2
Clamping head with longitudinal and transverse grooves	Dry	1.1	1.0
	Wet* / MMS**	1.3	1.2
Clamping head with Z or F serrations	Dry	1.0	1.0
	Wet* / MMS**	1.2	1.1

* Wet machining: Use of cooling lubricant [KSS]

** MMS [MQL]: Use of minimum-quantity lubrication

Table 7: Contact factor

Specific cutting forces

These are approximate values, reflecting the relatively arbitrary sub-categorization of materials. As a result, relatively large deviations from real values can be present.

For deviating workpiece materials and/or for machining tasks in the boundary area of the clamping device, the respective k_c values of the workpiece material being machine needs to be determined precisely, and/or the supplier of the material needs to be consulted.

SPANNTOP mini pull-back

Use and limits of use

The following applies to drilling operations with a double-bladed tool:

$$f = \frac{f_n}{2}$$

Workpiece materials		Specific cutting forces	Specific cutting forces	Specific cutting forces
Designation	DIN [ISO]	$k_c \left[\frac{N}{mm^2} \right]$ at $f = 0.1mm^*$	$k_c \left[\frac{N}{mm^2} \right]$ at $f = 0.5mm^*$	$k_c \left[\frac{N}{mm^2} \right]$ at $f = 1.0mm^*$
Cast iron	For example EN-GJL-250	1980	1260	900
Spherulitic graphite iron [unhardened]	For example EN-GJS-400-15	2120	1190	1060
construction steels without alloys or with only a low alloy content [of average strength] / cementation steels [unhardened]	For example S235JR [1.0037] S275JR [1.0044] Ck10 [1.1121] 16MnCr5 [1.7131] 18CrNi8[1.5920]	2920	1840	1500
construction steels without alloys or with only a low alloy content [unhardened, with higher strength]	S355J2G3 [1.0570] E360 [1.0070]	3350	2000	1600
Tempered steels [pre-annealed]	C45 [1.0503] C60 [1.0601] 42CrMo4 [1.7225] 34CrNiMo6 [1.6582]	2850	1960	1660
tool steels without alloys or with only a low alloy content [unhardened]	C105W1 [1.1545]	3100	2100	1690
Machining steels	35S20 [1.0726] 60S20 [1.0728]	1700	1480	1400
Stainless steels		3600	2450	2100
Hardened steels		4800		
Aluminum forging alloy <16% Si		1340	900	750
Aluminum casting alloy <16% Si		1520	1000	850
Brass		1300	850	700

* For feed rates between 0.05 mm and 0.1 mm, use the $f=0.1$ mm value with a 20% allowance.

** For feed rates between 0.1 mm and 0.5 mm, employ interpolation.

*** For feed rates between 0.5 mm and 1.0 mm, employ interpolation. For feed rates > 1.0 mm, use gap $f=1.0$ mm.

Table 8: Specific cutting forces

Friction coefficients

With workpieces made from a material other than steel, multiply these values by the correction values listed below.

When the workpiece is made of hardened steel, the values for smooth clamping heads always apply to ground workpiece surfaces.



NOTE

Damage to materials caused by using the wrong clamping head when clamping hardened materials!

- For the clamping of hardened materials, or of high-tensile materials $R_m > 1300 \left[\frac{N}{mm^2} \right]$, the only permitted clamping heads are smooth with longitudinal and transverse serrations!
- Other versions of clamping head may get damaged and lose their ability to achieve higher friction coefficients on soft materials.

		Clamping surface			
		SP	WS	SP	WS
Workpiece surface					
		Smooth clamping head	Clamping head with longitudinal and transverse serrations	Clamping head with Z serrations	Clamping head with F serrations
Finished, ground	$\mu_t = 0.06$ $\mu_a = 0.08$	$\mu_t = 0.07$ $\mu_a = 0.09$	$\mu_t = 0.15$ $\mu_a = 0.20$	$\mu_t = 0.17$ $\mu_a = 0.22$	
Finished to roughed	$\mu_t = 0.10$ $\mu_a = 0.13$	$\mu_t = 0.11$ $\mu_a = 0.15$	$\mu_t = 0.18$ $\mu_a = 0.25$	$\mu_t = 0.23$ $\mu_a = 0.28$	
Blank or unmachined	$\mu_t = 0.14$ $\mu_a = 0.16$	$\mu_t = 0.16$ $\mu_a = 0.18$	$\mu_t = 0.20$ $\mu_a = 0.28$	$\mu_t = 0.25$ $\mu_a = 0.30$	
Material correction values	Aluminum alloys = 0.97 Brass = 0.92 Cast iron = 0.80				

WS Workpiece

SP Clamping element

Table 9: Friction coefficient for steel workpieces

Clamping head mass $m[kg]$ and distance of mass center of gravity of clamping head segments to the rotational axis $r_s[m]$

Size of clamping head	Distance to mass center of gravity $r_s[m]$ in smallest position	Clamping head mass $m[kg]$
32	0.015	0.55
42	0.021	0.70
52	0.022	1.00
65	0.027	2.20
80	0.032	2.70
100	0.045	3.60
125	0.061	9.10
140	0.062	9.10
160	0.075	12.20

Table 10: Clamping head mass and distance of mass center of gravity of clamping head segments to the rotational axis

Determining the required clamping force



INFORMATION

S from Table 5

c from Table 7

k_c from Table 8

μ_a, μ_t from Table 9

r_s, m from Table 10

I

$$F_{rad\ erf} = S * c * (1.6 * (F_{sz} + F_{sk}) + F_{fz})$$



INFORMATION

Factor 1.6 takes account of possible fluctuations that may occur during power transmission.

II

$$F_{SZ} = 1.3 * \sqrt{\left(\frac{F_c * d_z + 2 * M_B}{d_{sp} * \mu_t}\right)^2 + \left(\frac{F_c + F_B}{\mu_a}\right)^2}$$

Turning [inner and outer]

$$F_c = 1.3 * a_p * f * k_c$$

Drilling [drilling solid materials, double-bladed tool, concentrically towards the workpiece axis]

$$F_B = 0.45 * D_B * f_n * k_c$$

$$M_B = \frac{f_n * D_B^2 * k_c}{5700}$$



INFORMATION

When calculating machining forces, a level of tool blunting is built in, corresponding to a wear mark width of 0.3mm.

III

$$F_{sk} = \frac{\left(0.27 * \frac{L_z}{d_{sp}} + 0.63\right) * \sqrt{\left(F_c * L_z + F_G * L_g\right)^2 + \left(F_c * P\right)^2}}{0.5 * \left(0.67 * \left(1.9 * L_{sp} - 4.5mm\right) + \mu_a * d_{sp}\right)}$$

Longitudinal turning

$$P = \frac{d_z}{2}$$

Surface turning / plunge-machining

$$P = L_z$$

If the workpiece is braced against a tailstock, it is OK to continue calculating with 20% from the computed F_{sk} value.

IV

$$F_{fz} = m * r_s * \left(\frac{\pi * n}{30}\right)^2$$

With reference to the principle defined at the start, this means that the radial clamping force of the clamping head chuck equates to at least the computed level of radial clamping force required $F_{rad\ erf}$ to resolve this use of the clamping head chuck.

If this condition is not satisfied, the clamping head chuck would not be suitable. It would not then be possible to perform this machining task.

When clamping and machining workpieces with bigger errors in axial and face run-out, please note that the cutting cross-section fluctuates greatly. Particular attention needs to be paid to the resultant local increase in cutting force.

Determining the required clamping force for radial drilling operations

With radial drilling operations directed at the center, radial clamping force $F_{rad\ erf}$ is also determined in accordance with an approach

$$F_{rad\ erf} = S * c * (1.6 * (F_{sz} + F_{sk}) + F_{fz})$$

whereby, although based upon components $F_{sz} = 0$ and $F_{fz} = 0$, a simplified form [just transverse force] can be used:

$$F_{rad\ erf} = S * c * 1.6 * F_{sk}$$

Determining of F_{sk} can be calculated as follows for drilling operations performed radially in relation to the clamping device axis, in a similar way to Formula III:

$$F_{sk} = \frac{(0.27 * \frac{L_z}{d_{sp}} + 0.63) * (F_q * L_z + F_G * L_g)}{0.5 * (0.67 * (1.9 * L_{sp} - 4.5mm) + \mu_a * d_{sp})}$$

To calculate F_q , see the »Further to Principle 4: $F_q \leq F_{q\ max}$ « chapter.

$$F_q = F_B = 0.45 * D_B * f_n * k_c$$

5.2.5.2 Further to Principle 2: $F_t \leq F_{t\ max}$

When using a tailstock, due to the additional expanding force exerted on the clamping head chuck, the permitted maximum tailstock force is limited to the following values in accordance with the size of the clamping head chuck:

Size of the clamping head chuck	$F_{t\ max}$ [kN]
32	3
42	6
52	6
65	8
80	8
100	8
125	8
140	8
160	8

Table 11: Maximum permitted tailstock force



NOTE

Serious damage to materials on clamping equipment and machine tool due to non-adapted forces!

- The total of set tailstock force and axial clamping force during the clamping process must be exceeded by the release force.

When operating with a tailstock, using an end-stop in the clamping head chuck ensures that the workpiece is not displaced axially.

5.2.5.3 Further to Principle 3: $F_c \leq F_{c\ max}$

The cutting force for turning operations can achieve very high levels, especially if the workpiece does not protrude far, although machining involves no slip or leverage forces that could displace the workpiece. Therefore the cutting force also needs to be limited to reflect the size of the clamping head chuck to prevent damage to the clamping head chuck.

Size of the clamping head chuck	Up to total chuck length $L[mm]$	$F_{c\ max}[N]$
32	< 120	1900
42	< 125	3600
52	< 125	3600
65	< 140	5000
80	< 140	6000
100	< 160	8000
125	< 200	12000
140	< 200	12500
160	< 200	14000

Table 12: Maximum permitted cutting force

On extended chuck versions, the ratio of maximum permitted cutting force to chuck lengths needs to be reduced. For example, size 32 with $L = 150mm$

$$\frac{120mm}{150mm} * 1900N = 1520N$$

5.2.5.4 Further to Principle 4: $F_q \leq F_{q\ max}$

With drilling operations radial to the workpiece axis, the feed force of the tool generates transverse forces that ultimately act on the clamping head chuck. The application of this load during drilling operations should be viewed as equivalent to the cutting force exerted by a turning process. Accordingly, it also has to be limited. Consult the following table for the permitted maximum values.

Feed force occurring while drilling F_B [transverse force]
 [drilling of solid materials, double-bladed tool, direction of machining at an angle of 90° to the chuck axis]

$$F_q = F_B = 0.45 * D_B * f_n * k_c$$



INFORMATION

k_c from Table 8

Size of the clamping head chuck	Up to total chuck length L [mm]	$F_{q\ max}$ [N]
32	< 120	2200
42	< 125	4200
52	< 125	4200
65	< 140	6000
80	< 140	7200
100	< 160	9000
125	< 200	13000
140	< 200	13800
160	< 200	15000

Table 13: Maximum permitted transverse force

On extended chuck versions, the ratio of maximum permitted transverse force to chuck lengths needs to be reduced. For example, size 32 with $L = 150\text{mm}$

$$\frac{120\text{mm}}{150\text{mm}} * 2200\text{N} = 1760\text{N}$$

5.2.5.5 Further to Principle 5: $M_q \leq M_{q \max}$

With drilling operations that are radial to the workpiece axis, the transverse force examined under Principle 4 exerts an additional torque M_q on the clamping head and/or on the chuck. This moment must not rise in an unlimited way to prevent damage to the clamping head chuck, even if the clamping of the workpiece may still hold firmly. The following table shows the related permissible maximum values.

Torque M_q occurring through the introduction of transverse force F_q

$$M_q = F_q * L_q$$

Size of the clamping head chuck	Up to total chuck length L [mm]	$M_{q \max}$ [Nm]
32	< 120	120
42	< 125	210
52	< 125	210
65	< 140	300
80	< 140	360
100	< 160	450
125	< 200	650
140	< 200	690
160	< 200	750

Table 14: Maximum permitted torque due to transverse force

On extended chuck versions, the ratio of maximum permitted torque to chuck lengths needs to be reduced. For example, size 32 with $L = 150\text{mm}$

$$\frac{120\text{mm}}{150\text{mm}} * 120\text{Nm} = 96\text{Nm}$$

5.2.6 Sample calculation

Applied to a specific example

Longitudinal turning of an offset shaft made of 16MnCr5 [blank clamping diameter] unsupported in a horizontal position.

Workpiece data

- Clamping diameter $d_{sp} = 60mm$
- Workpiece length $L_w = 150mm$ [151.5mm blank]
- Machining diameter of turning operation $d_z = 57.0mm$
- Workpiece mass $m_w = 3.3kg$
 - $F_G = m_w * 9.81 \frac{m}{s^2}$
 - $F_G = 33N$

Process data

- Speed $n = 800min^{-1}$
- Feed $f = 0.25mm$
- Chip-cutting depth $a_p = 1.5mm$
- Use of cooling lubricant
- Total clamping length $L_{spv} = 20mm$

Clamping head chuck

- Pull-back SPANNTOP size 65
- Clamping head used
 - Smooth
 - Clamping diameter of clamping head $D = 60mm$
 - Front-end length $L_v = 3mm$

Detailed observation

This satisfies the first condition, which is that the unclamping length must not exceed six times the clamping diameter.

This also satisfies the second condition, which is that the workpiece mass must not exceed m_w 40kg of size 65 of clamping head chuck.

This more than satisfies the third condition, which is that the workpiece must at least be clamped with $0.08 * d_{sp} = 0.08 * 60mm = 4.8mm$, with a clamping length of $L_{sp} = L_{spv} - L_v = 20mm - 3mm = 17mm$.

To check the fourth condition, the required level of clamping force needs to be established first, in accordance with Principle 1.



INFORMATION

S from Table 5

c from Table 7

k_c from Table 8 [interpolated for $f = 0.25\text{mm}$]

μ_a, μ_t from Table 9

r_s, m from Table 10

I

$$F_{rad\ erf} = S * c * (1.6 * (F_{SZ} + F_{Sk}) + F_{fz})$$

from Table 5 $S = 1.6$

from Table 7 $c = 1.3$

$$F_{rad\ erf} = 1.6 * 1.3 * (1.6 * (F_{SZ} + F_{Sk}) + F_{fz})$$

II

$$F_{SZ} = 1.3 * \sqrt{\left(\frac{F_c * d_z + 2 * M_B}{d_{sp} * \mu_t}\right)^2 + \left(\frac{F_c + F_B}{\mu_a}\right)^2}$$

from Table 9 $\mu_t = 0.14, \mu_a = 0.16$

Turning:

$$F_c = 1.3 * a_p * f * k_c$$

$$F_c = 1.3 * 1.5\text{mm} * 0.25\text{mm} * 2515 \frac{\text{N}}{\text{mm}^2} = 1226\text{N}$$

Drilling:

Not relevant here because no drilling is envisaged. Therefore $F_B = 0\text{N}$ and $M_B = 0\text{Nmm}$

$$F_{SZ} = 1.3 * \sqrt{\left(\frac{1226\text{N} * 57\text{mm} + 2 * 0\text{Nmm}}{60\text{mm} * 0.14}\right)^2 + \left(\frac{1226\text{N} + 0\text{N}}{0.16}\right)^2}$$

$$F_{SZ} = 14703\text{N}$$

III

$$F_{sk} = \frac{\left(0.27 \cdot \frac{L_z}{d_{sp}} + 0.63\right) \cdot \sqrt{(F_c \cdot L_z + F_G \cdot L_g)^2 + (F_c \cdot P)^2}}{0.5 \cdot (0.67 \cdot (1.9 \cdot L_{sp} - 4.5 \text{mm}) + \mu_a \cdot d_{sp})}$$

$L_z = L_w = 133 \text{mm}$, since the shaft should be surface-turned at the front end of the shaft.

$L_g = 75 \text{mm}$, since the center of gravity is located centrally on the longitudinal axis of the work-piece.

$L_{sp} = 17 \text{mm}$, corresponds to the total clamping length less the front-end length of the clamping head.

$P = \frac{d_z}{2} = \frac{57 \text{mm}}{2} = 28.5 \text{mm}$, because of a longitudinal turning operation

$$F_{sk} = \frac{\left(0.27 \cdot \frac{133 \text{mm}}{60 \text{mm}} + 0.63\right) \cdot \sqrt{(1226 \text{N} \cdot 133 \text{mm} + 33 \text{N} \cdot 75 \text{mm})^2 + (1226 \text{N} \cdot 28.5 \text{mm})^2}}{0.5 \cdot (0.67 \cdot (1.9 \cdot 17 \text{mm} - 4.5 \text{mm}) + 0.16 \cdot 60 \text{mm})}$$

$$F_{sk} = \frac{207838 \text{Nmm}}{14.11 \text{mm}} = 14727 \text{N}$$

IV

$$F_{fz} = m \cdot r_s \cdot \left(\frac{\pi \cdot n}{30}\right)^2$$

from Table 10: $m = 2.2 \text{kg}$, $r_s = 0.027 \text{m}$

$$F_{fz} = 2.2 \text{kg} \cdot 0.027 \text{m} \cdot \left(\frac{\pi \cdot 800 \text{min}^{-1}}{30}\right)^2$$

$$F_{fz} = 417 \text{N}$$

$$F_{rad\ erf} = 1.6 \cdot 1.3 \cdot (1.6 \cdot (F_{sz} + F_{sk}) + F_{fz})$$

$$F_{rad\ erf} = 1.6 \cdot 1.3 \cdot (1.6 \cdot (14703 \text{N} + 14727 \text{N}) + 417 \text{N})$$

$$F_{rad\ erf} = 98810 \text{N} = 99 \text{kN}$$

Since the size 65 clamping head chuck can exert a maximum radial clamping force of $F_{rad\ max} = 105 \text{kN}$, this satisfies Principle 1.

In this example, Principle 2 does not apply because work is performed without a tailstock in this case.

Principle 3 would also be satisfied, because the calculated cutting force of $F_c = 1226 \text{N}$ is well below the limit of $F_{c\ max} = 4500 \text{N}$.

On the other hand, Principles 4 and 5 are immaterial in this example because both principles only need to be considered in relation to radial drilling operations.

Result of the sample calculation

All limits have been checked.

The axial actuation force is proportional to the radial clamping force and interpolation can therefore be used to determine this on the basis of the values for $F_{ax\ max}$ and $F_{rad\ max}$, as indicated on the clamping head chuck, or you can consult the clamping force diagram [see »Clamping force diagram« chapter].

When full axial force is exerted on the clamping head chuck with $F_{ax\ max} = 45\text{kN}$, nominal radial 105kN forces are being applied to the workpiece.

In the example calculated here, an axial force of at least $F_{ax} = 43\text{kN}$ must be applied, resulting in a radial clamping force of $F_{rad} = 99\text{kN}$.

This satisfies condition $F_{rad} \geq F_{rad\ erf}$.

Machining can then be performed.

The value is close to the limit value. This ensures that the clamping head chuck is in good condition in terms of the level of contamination.

It is advisable to conduct a check on radial clamping force using an appropriate clamping force meter before the machining operation. The values established must lie within an appropriate range for the rotational speed [see »Clamping force diagram« chapter].

6 Transport, packaging, storage

6.1 Safety, transport, packaging, storage



WARNING

High level of physical strain due to the weight of the product or of its components if not transported properly!

- From a weight of 10 kg, use appropriate transport equipment, lifting gear and lifting tackle.



WARNING

Serious crushing injuries and breakages caused by falling parts if transported incorrectly!

- Ensure that the product cannot roll away or fall.
- Place on a non-slip surface.
- When using lifting gear, use appropriate load-bearing equipment and lifting tackle.



WARNING

Serious injuries caused by transporting off-center equipment!

- Pay attention to marks on the packaging items.
- Attach the crane hook directly above the center of gravity.
- Raise carefully and correct the lifting points if necessary.



WARNING

Serious injuries caused by incorrect transport with lifting gear!

- Never raise loads above people.
- Never step under suspended loads.
- Pay attention to information about the intended lifting points. Ensure that the lifting gear is mounted on a secure base.
- Only use authorized and undamaged lifting gear, load-bearing equipment and lifting tackle.
- Never exceed the maximum load-bearing capacity of lifting gear, load-bearing equipment and lifting tackle.



NOTE

Damage to materials caused by falling parts if transported incorrectly!

- Ensure that the product cannot roll away or fall.
- Place on a non-slip surface.
- When using lifting gear, use appropriate load-bearing equipment and lifting tackle.

6.2 Symbols on the packaging



Fragile

Designates packaging items with fragile or breakable contents.

Handle the packaging item with care. Do not drop it and protect it against collision impacts.



Keep it dry

Keep packaging items dry and protect them from the ingress of water.



Position designation

Points to the correct upright position of the packaging item.

6.3 Transport inspection

Check the delivery on receipt immediately to ensure it is complete and has not been damaged in transit.

Proceed as follows if you find any externally visible signs of damage while in transit:

- Refuse to accept the delivery, or only subject to later approval
- Make a note of the extent of damage on the transportation documents or on the delivery note of the transportation company
- Initiate a complaint



INFORMATION

Raise a complaint for every defect as soon as it is discovered. Compensation claims can only be enforced during the applicable complaint periods.

6.4 Unpacking and internal transportation

The total weight of the product depends on its size.

Depending on the weight involved, it may be necessary to use lifting gear to lift the product or its components out of the packaging safely, to transport them and to position and install them in the machine tool or on the machine table.

1. The product is packaged in a stable position, and it has threads / bores for transportation.
2. Lifting tackle can be installed in these transportation threads / bores. To lift the product out of its packaging, the front-end functional threads can if necessary be used to attach lifting tackle to upright packaged products.
3. Attach load-bearing equipment to the lifting tackle.
4. Subject to weight, use lifting gear to lift the product out of its packaging safely, and place it down on a stable, flat surface.
5. Secure the product to prevent it from rolling away.
6. When transporting on a trolley or car, ensure that the product is securely mounted on a non-slip surface before starting to move it.

6.5 Packaging

The individual packaging items are packaged in an appropriate manner for the type of transportation involved. Always use environmentally compatible materials for packaging purposes.

Packaging should protect individual components from damage in transit, corrosion and other forms of damage, up until installation. For this reason, do not destroy the packaging, and do not remove it until shortly before installation.



INFORMATION

The packaging units are packaged, wrapped in air-tight film and placed in cardboard boxes. On the individual weights of each of the sizes [see »General information« chapter].

Dispose of packaging material in accordance with applicable legislative provisions and local regulations.



NOTE

Damage to the environment caused by improper disposal of packaging materials!

- Dispose of packaging materials in an environmentally responsible manner.
- Pay attention to local disposal regulations and, if necessary, appoint a specialist waste disposal company with this work.

6.6 Storage



INFORMATION

The packaged items may display information relating to storage and readmission to storage that extend beyond the scope of these requirements. Pay attention to these notices.

Store packaged items under the following conditions:

- Safe for storage.
- Do not store outdoors.
- Store in a dry, dust-free place.
- Avoid exposure to aggressive media.
- Protect against direct sunlight.
- Avoid mechanical vibration.
- Storage temperature: 15 to 35°C.
- Relative humidity: Maximum 60%.
- In the event of storage for more than 3 months:
 - On a regular basis, check the general condition of all parts and packaging.
 - If necessary, refresh the preservation or replace it.

6.7 Preservation

1. Clean and lubricate the product [see »Cleaning« and »Lubricating the product« chapters].
2. Apply a light coating of preserving oil to the inner and outer faces of the product. Wipe away surplus preserving oil with a soft, lint-free, tear-resistant cloth.
3. Pack product air-tight in foil.
4. Return product to storage [see »Return to storage« chapter].

6.8 Return to storage

Return product to storage under the following conditions:

1. Preserve the product [see »Preservation« chapter].
2. The product must be stored in a safe condition. Use an appropriate container for the product, on a non-slip surface, or fit the floor of the shelving unit with an all-round safety border.
3. For storage conditions, see the »Storage« chapter.

7 Installation

7.1 Installation safety



WARNING

Serious injuries caused by unskilled staff during installation / removal!

- Installation and removal must be performed by skilled staff from the relevant specialist field.



WARNING

Serious injuries can be caused if the machine tool starts up accidentally!

- Set the machine tool into set-up mode.
- Remove all tools, auxiliary equipment and items of test equipment immediately from the working area of the machine.
- Remove all lifting gear from the product and from the working area of the machine.



WARNING

Serious injuries caused by the escape of media under high pressure!

- Shut down media delivery during installation and removal.
- Relieve any pressure trapped in the system.
- Shut down the system.



WARNING

Serious crushing injuries and breakages caused by falling parts during incorrect installation or removal!

- Ensure that the product cannot roll away or fall.
- If necessary, use an appropriate mounting aid for installation or removal on a vertically suspended machine spindle.



WARNING

Serious crushing injuries caused by improper machine movement during installation or removal!

- Machine movements are only permitted in set-up mode during installation and removal.
- Never reach into a gap.
- Pay attention to the gap dimensions of moving parts.



WARNING

Serious head injuries caused by bending into the working area of the machine!

- Only ever bend into the working area of the machine if there are no cutting tools or sharp objects in it, or if these are covered.
- Never move body parts under parts in the working area of the machine with the potential to drop down.
- Depending on weight, use an appropriate mounting aid for installation or installing on a vertically suspended machine spindle.



WARNING

High level of physical strain due to the weight of the product or of its components if not transported properly!

- From a weight of 10 kg, use appropriate transport equipment, lifting gear and lifting tackle.



CAUTION

Serious cut injuries caused by sharp-edged changing parts and/or clamping elements!

- All installation / removal of changing parts and clamping elements must be performed by skilled staff from the relevant specialist field.



NOTE

Damage to materials caused by lifting gear left in the product!

- Always remove lifting gear immediately after installing the product.



NOTE [only for aluminum components]

Damage to materials can be caused by incorrect screw tightening torques on aluminum components!

- Pay attention to the reduced screw tightening torques for aluminum components [see »Screw tightening torques« chapter].

7.2 Preliminary remarks

- In accordance with their thread size and strength class, screws must be tightened crosswise to the specified tightening torque [see »Screw tightening torques« chapter]. When tightening the screws, do so evenly to prevent any distortion under load.
- To avoid precision errors, clean all screw-fitting points and mating surfaces [Notes on cleaning, see »Cleaning« chapter]. Factory wetting of flat surfaces and, where necessary of clamping elements, only serves as a corrosion inhibitor. This is not functionally related lubrication.
- Only apply lubricant to the mechanical mating surfaces. Pay attention to notes about lubricants [see »Use of lubricants« chapter].
- Avoid too much lubricant on the locating face because this can cause face run-out errors.
- Apply grease to the sealing elements [for example O-rings, rectangular rings] and sealing surfaces. Pay attention to notes about greases [see »Use of lubricants« chapter].
- Do not damage the functional surfaces [flat, mating, tapered and sealing surfaces].

7.3 Screw tightening torques

The tables show the specified values.

Knowledge of the applicable guidelines and design criteria is essential.



NOTE

Damage to materials caused by defective screw tightening torques!

- To secure the product to the machine, pay attention to the values specified by HAINBUCH and by the machine manufacturer for screw tightening torques. If the machine manufacturer stipulates different values, you must consult HAINBUCH.

Metric control threads

The following table contains the guide values in Nm for screw tightening torques for achieving the highest permitted pre-load for metric control threads.

- Total friction coefficient $\mu_{ges} = 0.12$

Thread designation	Tightening torque at screw quality [Nm]	
	10.9	12.9
M4	4	5
M5	7	9
M6	12	15
M8	25	38
M10	50	70
M12	100	130
M16	220	300
M20	400	550
M24	600	800

Table 15: Screw tightening torques, metric control threads

Aluminum components

The following table contains the reduced screw tightening torques for securing aluminum components.

Thread designation	Tightening torque [Nm]	Minimum screw depth [mm]
M6	10	12
M8	23	16
M10	46	20

Table 16: Screw tightening torques for aluminum components

Screw plugs

The following table contains the guide values in Nm for screw tightening torques for achieving the highest permitted pre-load for screw plugs.

Thread designation	Tightening torque [Nm]
M8x1	10
M10x1	15
M12x1.5	25
M14x1.5	30
M16x1.5	50
M18x1.5	60
M20x1.5	70
M22x1.5	80
M24x1.5	100
M30x1.5	150
G1	150
G1/2	80
G1/4	30
G1/8	15
G3/8	50

Table 17: Screw tightening torques for screw plugs

7.4 Preparation of the machine for installation

1. Set the machine into set-up mode.



INFORMATION

The minimum operating pressure is reached when the drawtube can still just be moved without triggering an error message.

2. Reduce the operating pressure to a minimum.
3. Remove cutting tools and/or sharp objects from the working area of the machine, or cover them.

7.5 Installation of the product

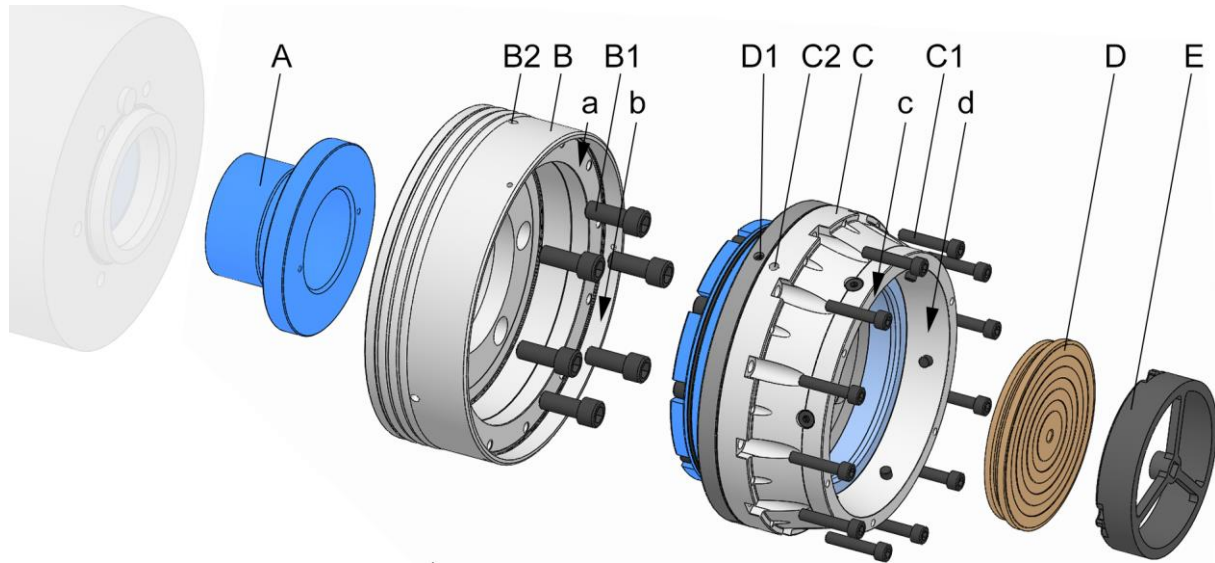

- A Drawtube adapter
- B Spindle flange
- B1 Fixing screws, spindle flange
- B2 Transport thread spindle flange
- C Functional unit
- C1 Fixing screws functional unit
- C2 Transport thread functional unit
- D Base end-stop
- D1 Clamping screw base end-stop
- E Assembly wrench adapter
- a Test surface face run-out spindle flange
- b Test surface axial run-out spindle flange
- c Test surface face run-out functional unit
- d Test surface axial run-out functional unit

Special aids needed:

- Assembly wrench adapter
1. As described in the »Preparation of the machine for installation« chapter, prepare for the following steps.

7.5.1 Compatibility check

Check the compatibility of the product and the connection point of the machine.

For this, check that the connection point and the product share the same adaptation geometry. Also check if the actuating element / coupling element is suitable.

It may be necessary to install an adapter between the actuating element on the machine and the product.

7.5.2 Preparation of the product

The product is supplied in assembled condition.

The following preparatory steps are needed to install the product.

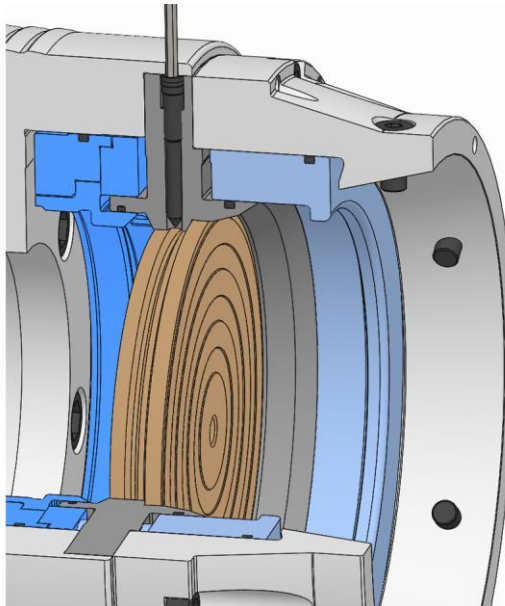

1. Unscrew the clamping screws from the base end-stop until the base end-stop can be lifted out.

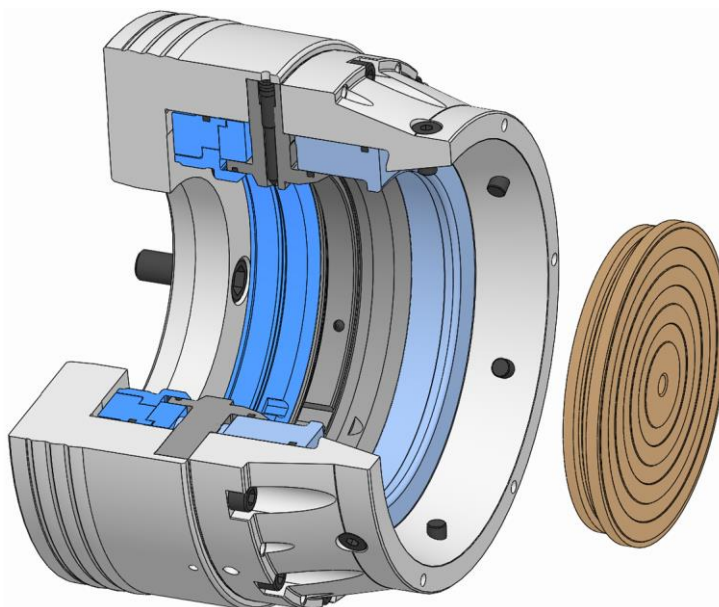

INFORMATION

To install / remove the changing part in / from the product, it may be necessary to use a grab handle or an appropriate auxiliary tool.

2. Remove the base end-stop from the product.



INFORMATION

The drawtube adapter may already be installed in the clamping device.

Depending on the geometry of the drawtube adapter, it may be necessary to remove the drawtube adapter to be able to dismantle the functional unit from the spindle flange.

3. If necessary, unscrew and remove the drawtube adapter from the product.

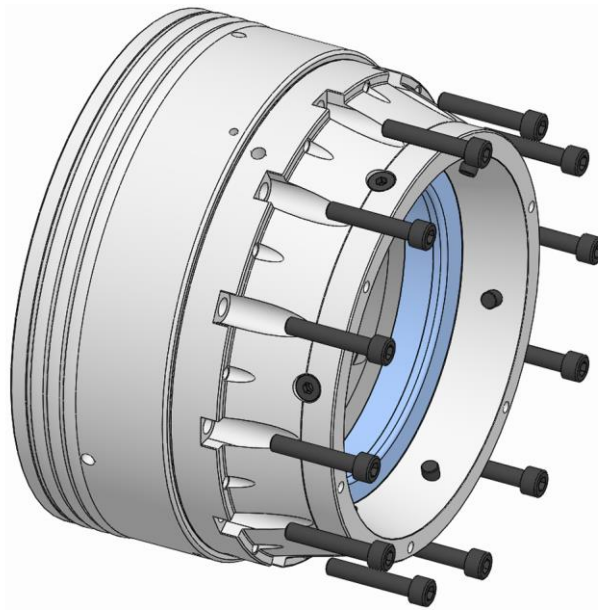

4. Unfasten and remove the fixing screws on the functional unit.



INFORMATION

To install the functional unit on the machine, you need to know if this product can or cannot be aligned.

Check the order confirmation. If the clamping device can be aligned, the order confirmation will have a note to this effect.

And/or check if there is clearance at the interface between spindle flange and functional unit. For this, slide the spindle flange and functional unit together. If the functional unit can be moved in the spindle flange, the clamping device can be aligned.

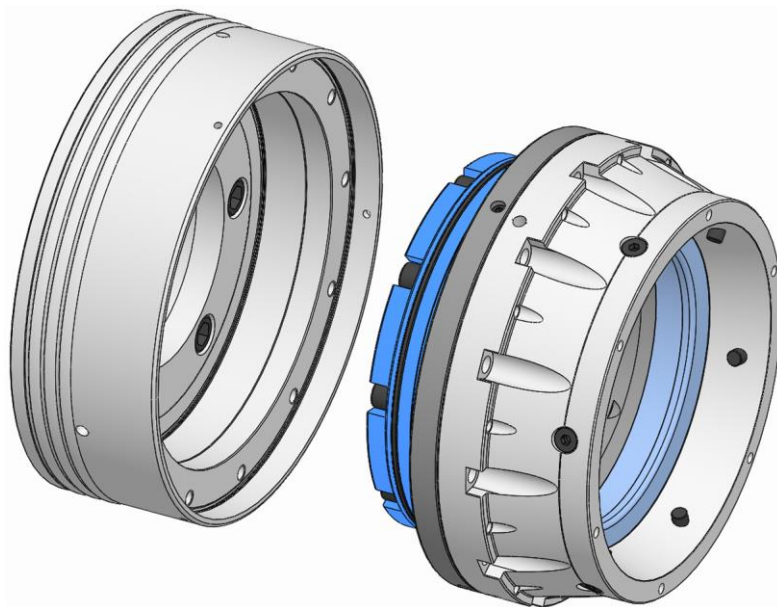

5. Take down the functional unit from the spindle flange.

7.5.3 Installation of the drawtube adapter



INFORMATION

Depending on the geometry of the drawtube adapter, it must be installed either on the machine drawtube or in the functional unit.

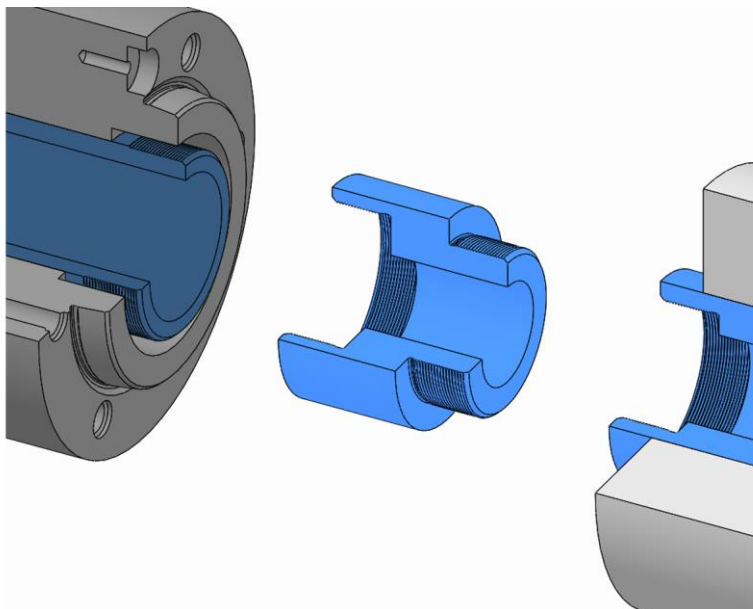

1. Screw the drawtube adapter into the functional unit using its thread or screw it to the machine drawtube and tighten it down.

7.5.4 Installation of a spindle flange that cannot be aligned

1. Attach any lifting gear that may be required.
2. If necessary, fit the mounting aid onto a vertically suspended spindle.

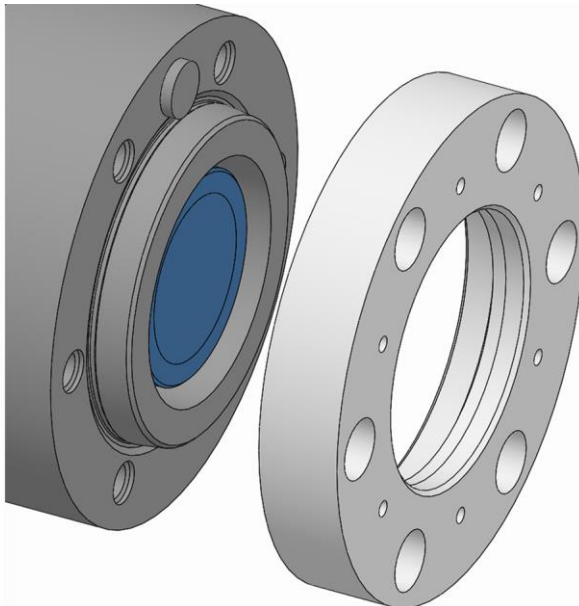
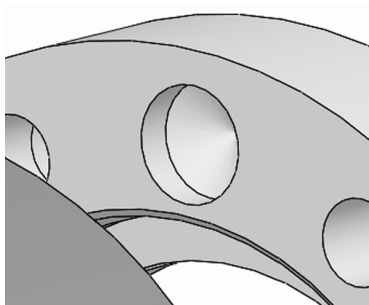

INFORMATION

The positioning block on the machine spindle and the positioning bore in the spindle flange can be used for positioning.

3. Fit the spindle flange on the machine spindle. If necessary, position the spindle flange over the machine spindle using its bore.

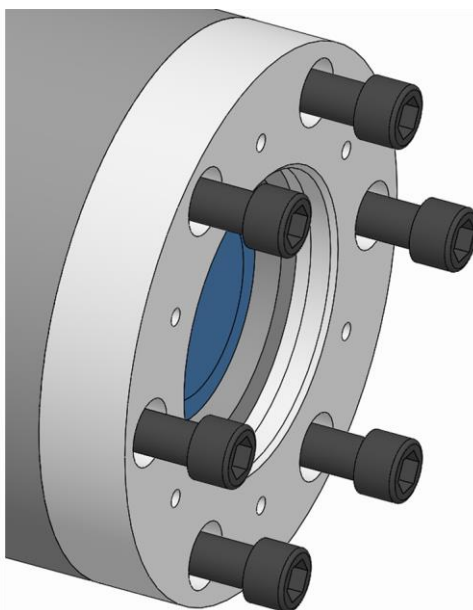

4. Screw in the changing part fixing screws on the spindle flange and tighten to the specified tightening torque [see »Screw tightening torques« chapter].

5. Unfasten and remove any lifting gear that may have been required.
6. Remove the mounting aid on a vertically suspended spindle if one was used.
7. Check face run-out on the test surface of the spindle flange [ideally ≤ 0.005 mm].
8. Check axial run-out on the test surface of the spindle flange [ideally ≤ 0.005 mm].

Whenever the face run-out and/or the axial run-out is greater than the maximum permitted value:

9. Remove the spindle flange.
10. Clean the locating face and the mating faces of the machine spindle and the spindle flange.
11. If there is a burr or slight damage, rub down the locating face of the spindle flange and the machine spindle gently with an oil stone.
12. Reinstall the spindle flange.
13. Repeat the face run-out test.
14. Repeat the axial run-out test.

7.5.5 Installation of a spindle flange that can be aligned

1. Attach any lifting gear that may be required.
2. If necessary, fit the mounting aid onto a vertically suspended spindle.

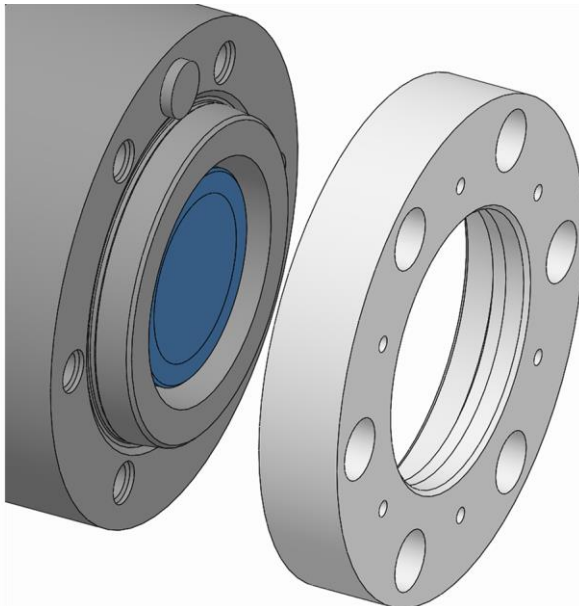
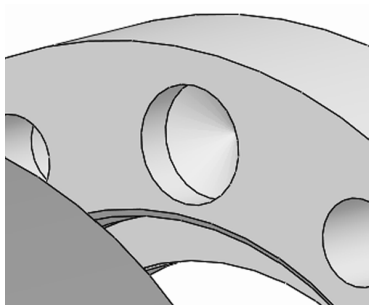

INFORMATION

The positioning block on the machine spindle and the positioning bore in the spindle flange can be used for positioning.

3. Fit the spindle flange on the machine spindle. If necessary, position the spindle flange over the machine spindle using its bore.

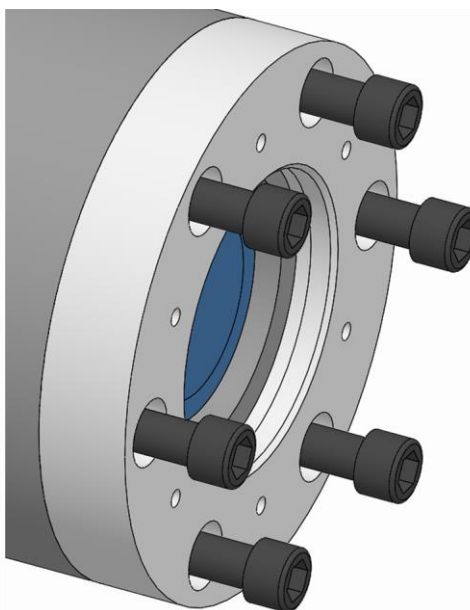

4. Screw in the spindle flange fixing screws and tighten them gently.

5. Unfasten and remove any lifting gear that may have been required.
6. Remove the mounting aid on a vertically suspended spindle if one was used.
7. Check the face run-out on the test surface of the spindle flange [ideally ≤ 0.005 mm] and, if necessary, correct carefully with a plastic hammer.

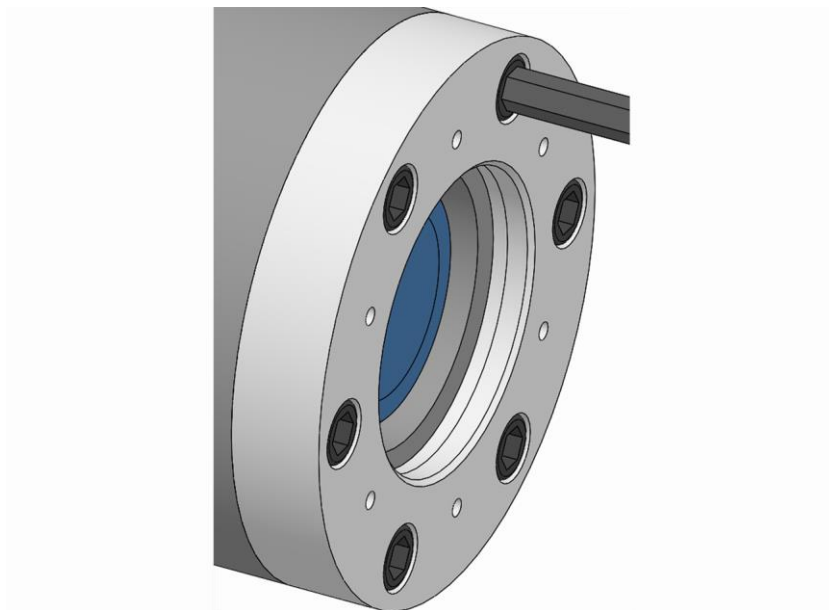

8. Screw in the drift body fixing screws on the spindle flange and tighten to the specified tightening torque [see »Screw tightening torques« chapter].
9. Check face run-out on the test surface of the spindle flange [ideally ≤ 0.005 mm].

Whenever the face run-out is greater than the maximum permitted value:

10. Remove the spindle flange.
11. Clean the locating face and the mating faces of the machine spindle and the spindle flange.
12. If there is a burr or slight damage, rub down the locating face of the spindle flange and the machine spindle gently with an oil stone.
13. Reinstall the spindle flange.
14. Repeat the alignment process.
15. Repeat the face run-out test.

7.5.6 Installation of the functional unit of an alignable clamping device

1. Attach any lifting gear that may be required.
2. If necessary, fit the mounting aid onto a vertically suspended spindle.
3. Move the machine drawtube to the front limit stop.

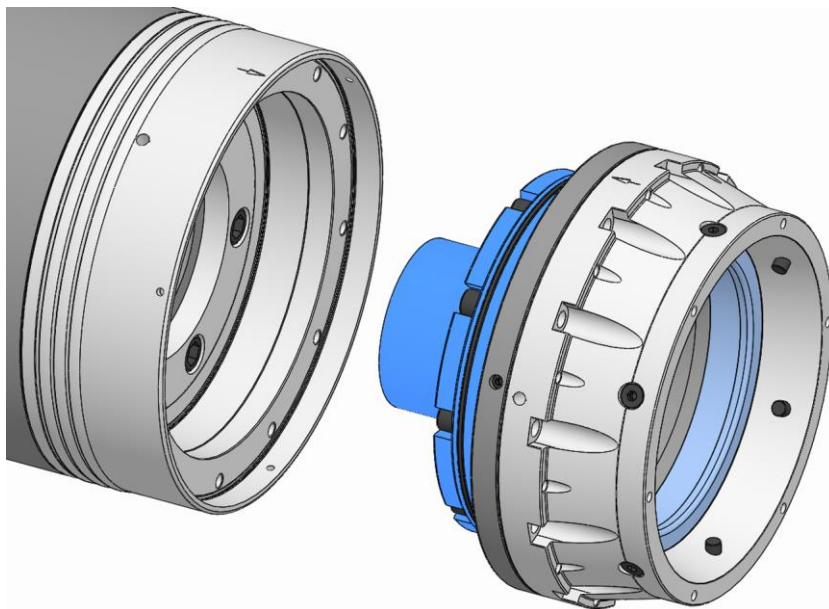

4. Fit the functional unit on the spindle flange until the balancing marks on the spindle flange are aligned with those on the functional unit.

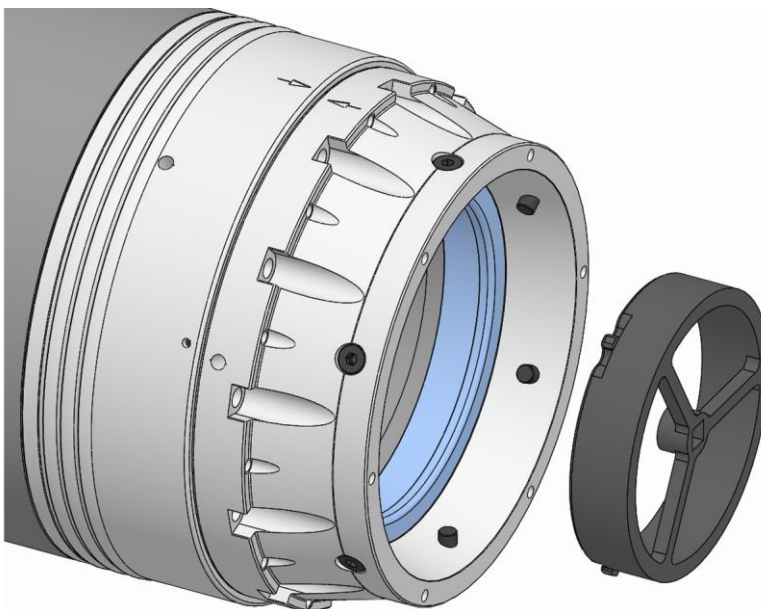

5. Install the mounting aid in the functional unit to enable the mounting aid to engage in the grooves of the drawtube adapter in the functional unit.

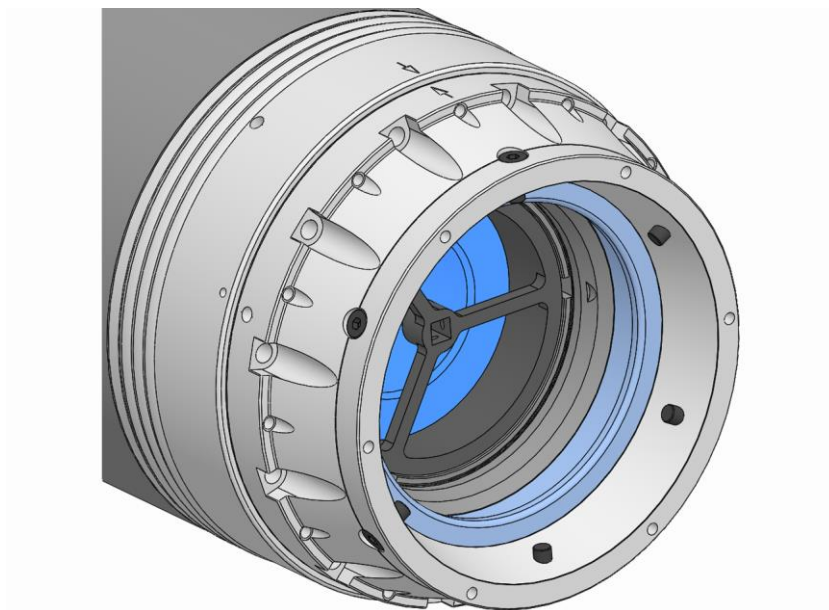

6. Using the mounting aid, screw the drawtube adapter of the functional unit firmly home on the machine drawtube.

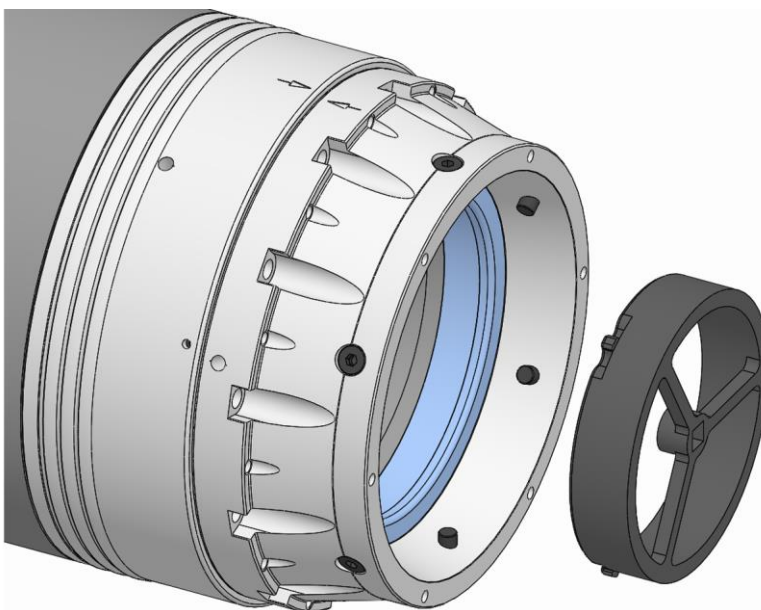

7. Remove the mounting aid from the functional unit.



WARNING

Serious crushing injuries caused by improper machine movement during installation!

- Never reach into the gap between machine tool, spindle flange and functional unit.

8. Using the least possible force and speed, move the drawtube on the machine to its rear limit stop [see »Preparing the machine for installation« chapter].

SPANNTOP mini pull-back Installation

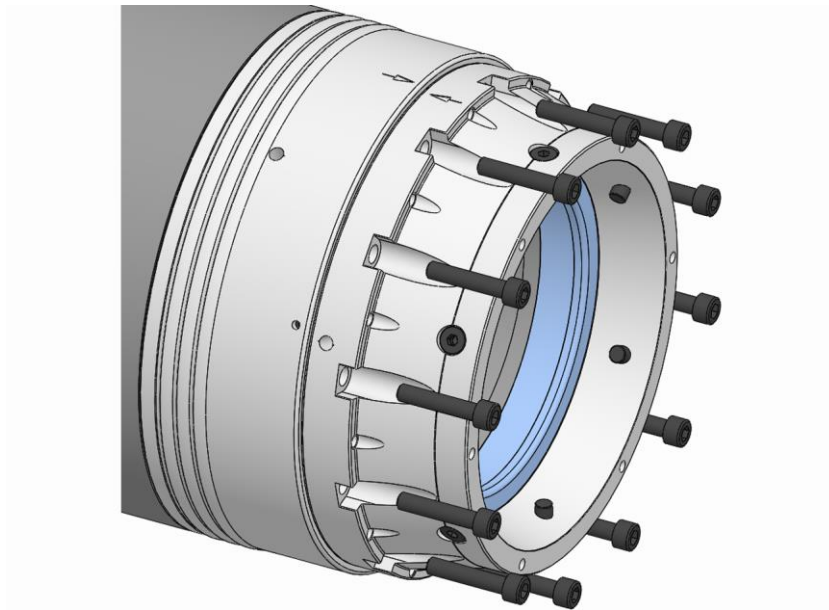

9. Screw in the fixing screws on the functional unit and tighten them gently.
10. Unfasten and remove any lifting gear that may have been required.
11. Remove the mounting aid on a vertically suspended spindle if one was used.
12. Check the face run-out on the test surface of the functional unit [ideally ≤ 0.01 mm] and, if necessary, correct carefully with a plastic hammer.

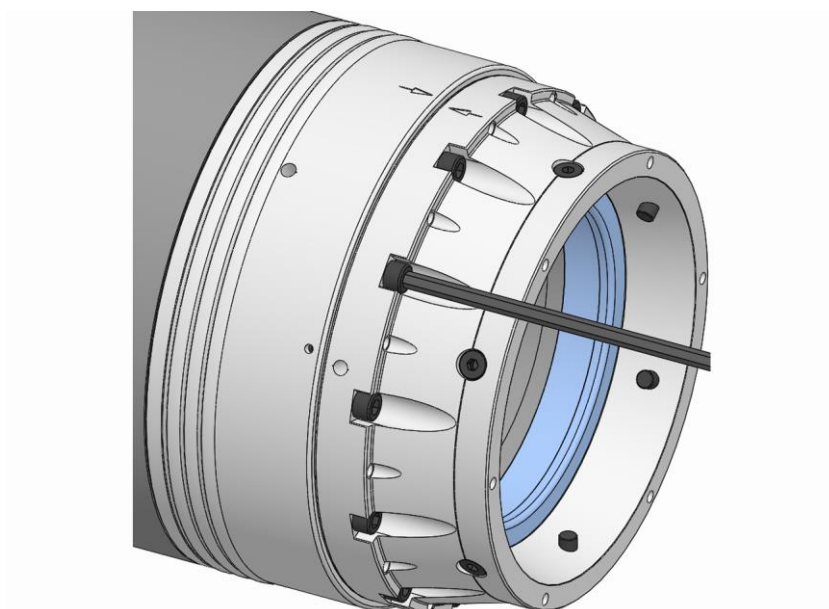

13. Tighten the fixing screws on the functional unit to the specified tightening torque [see »Screw tightening torques« chapter].
14. Check face run-out on the test surface of the functional unit [ideally ≤ 0.01 mm].

Whenever the face run-out is greater than the maximum permitted value:

15. Remove the functional unit.
16. Clean the locating face and the mating faces of the spindle flange and the functional unit.
17. If there is a burr or slight damage, rub down the locating face of the spindle flange or the functional unit gently with an oil stone.
18. Reinstall the functional unit.
19. Repeat the alignment process.
20. Repeat the face run-out test.

7.5.7 Installation of the functional unit of a non-alignable clamping device

1. Attach any lifting gear that may be required.
2. If necessary, fit the mounting aid onto a vertically suspended spindle.
3. Move the machine drawtube to the front limit stop.

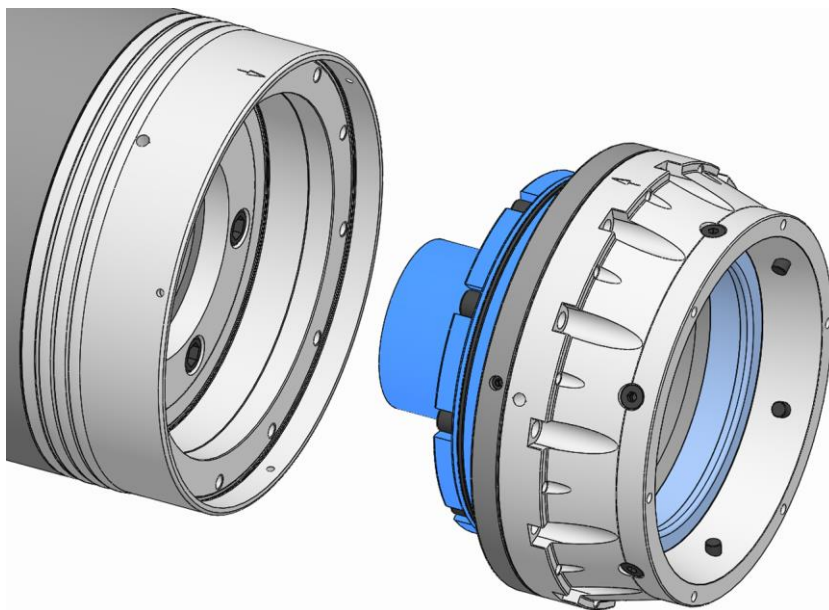

4. Fit the functional unit on the spindle flange until the balancing marks on the spindle flange are aligned with those on the functional unit.

SPANNTOP mini pull-back Installation

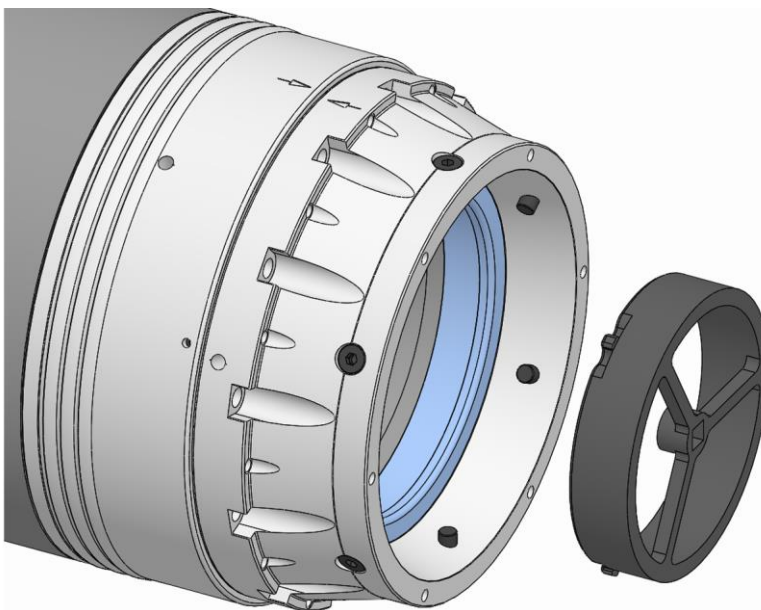

5. Install the mounting aid in the functional unit to enable the mounting aid to engage in the grooves of the drawtube adapter in the functional unit.

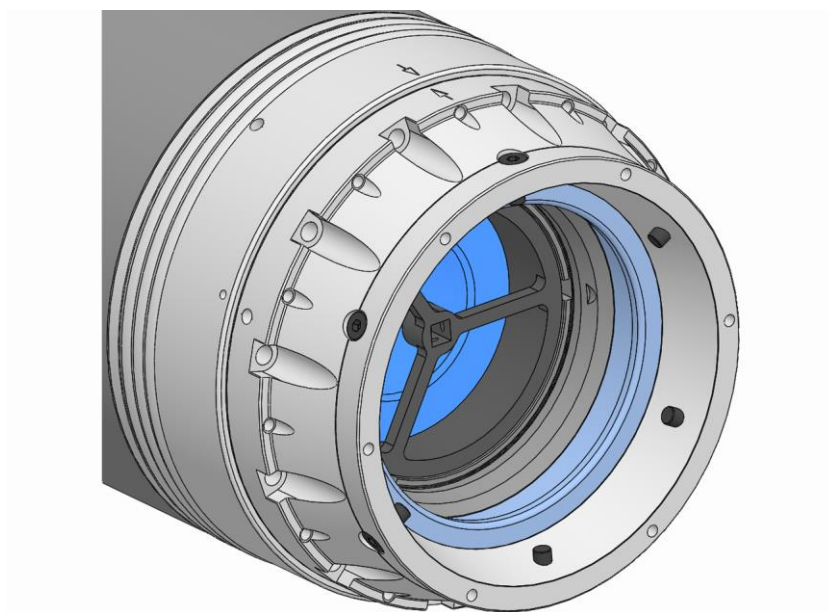

6. Using the mounting aid, screw the drawtube adapter of the functional unit firmly home on the machine drawtube.

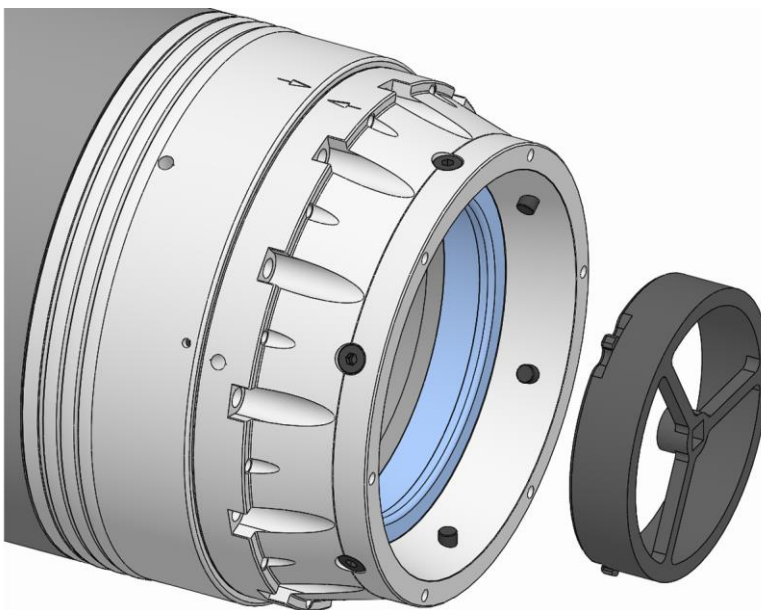

7. Remove the mounting aid from the functional unit.



WARNING

Serious crushing injuries caused by improper machine movement during installation!

- Never reach into the gap between machine tool, spindle flange and functional unit.

8. Using the least possible force and speed, move the drawtube on the machine to its rear limit stop [see »Preparing the machine for installation« chapter].

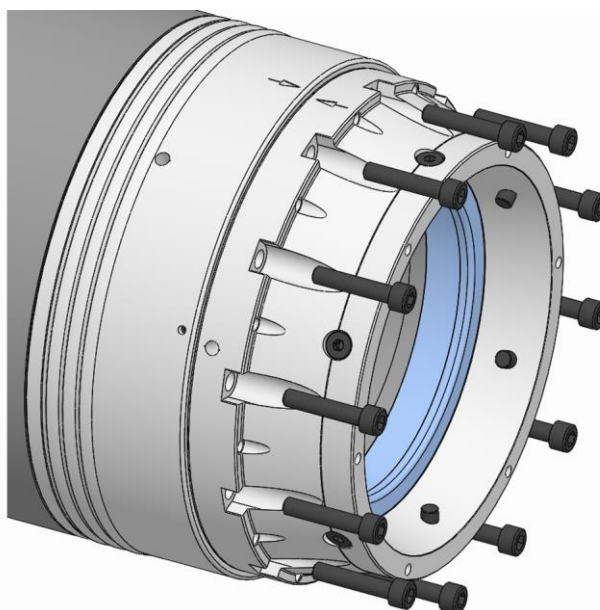

9. Screw in the fixing screws on the functional unit and tighten to the specified tightening torque [see »Screw tightening torques« chapter].

10. Unfasten and remove any lifting gear that may have been required.
11. Remove the mounting aid on a vertically suspended spindle if one was used.
12. Check face run-out on the test surface of the functional unit [ideally ≤ 0.01 mm].
13. Check axial run-out on the test surface of the functional unit [ideally ≤ 0.01 mm].

Whenever the face run-out and/or the axial run-out is greater than the maximum permitted value:

14. Remove the functional unit.
15. Clean the locating face and the mating faces of the spindle flange and the functional unit.
16. If there is a burr or slight damage, rub down the locating face of the spindle flange or the functional unit gently with an oil stone.
17. Reinstall the functional unit.
18. Repeat the face run-out test.
19. Repeat the axial run-out test.

7.6 Installation of the clamping element

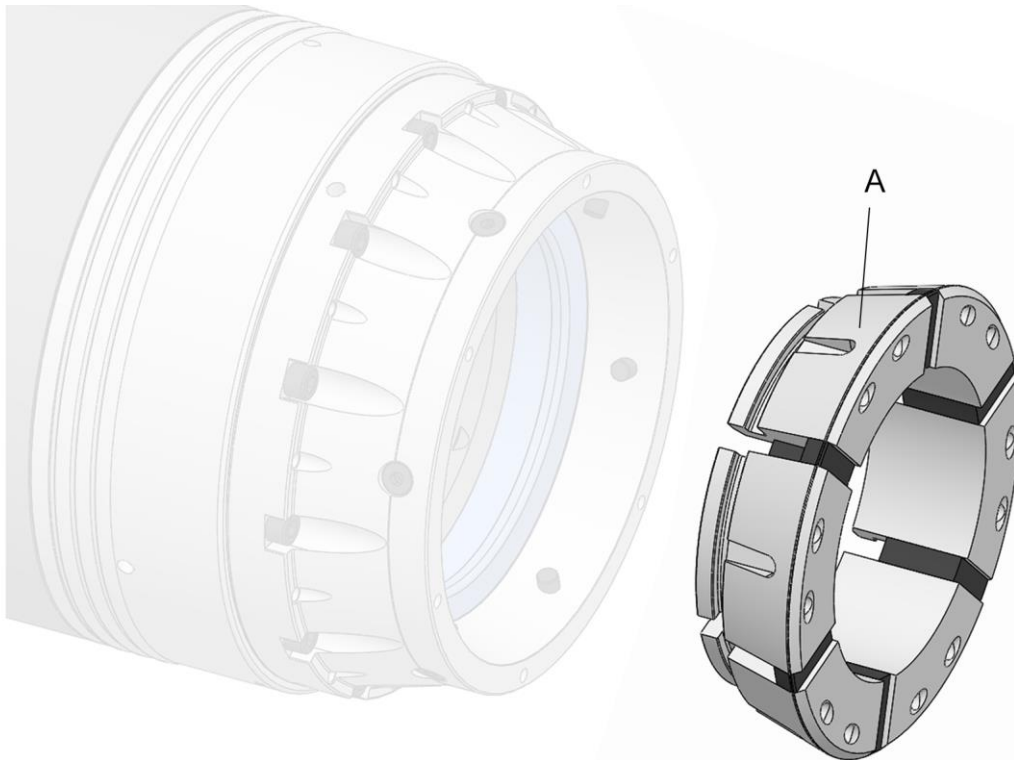

A Clamping head [clamping element]



INFORMATION

Before installing the clamping element, install the changing part if necessary, otherwise it can no longer be installed.

Special aids needed:

- Changing fixture
- 1. As described in the »Preparation of the machine for installation« chapter, prepare for the following steps.
- 2. Move the clamping device into release position.

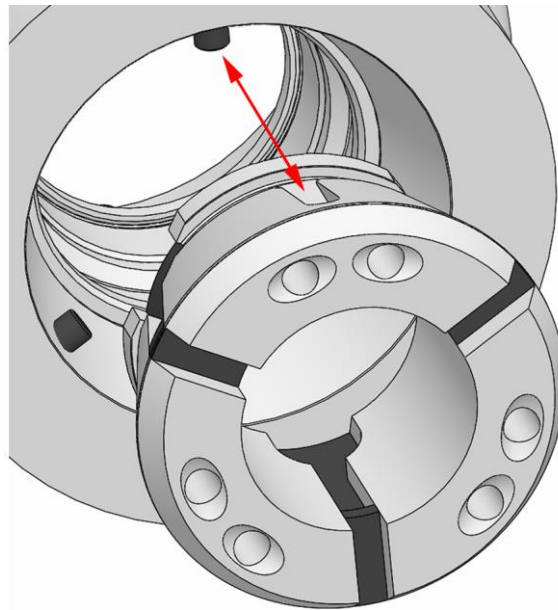

WARNING

Serious crushing injuries caused by reaching into the coupling / slot area in the clamping head or into the changing fixture!

- During actuation, never reach into the coupling / slot area in the clamping head or into the changing fixture.

3. Install the clamping head in the product with an appropriate changing fixture. For this the anti-twist devices in the clamping taper of the product and the grooves in the clamping head must be aligned.
4. Unfasten and remove the changing fixture.

7.7 Installation of the changing parts

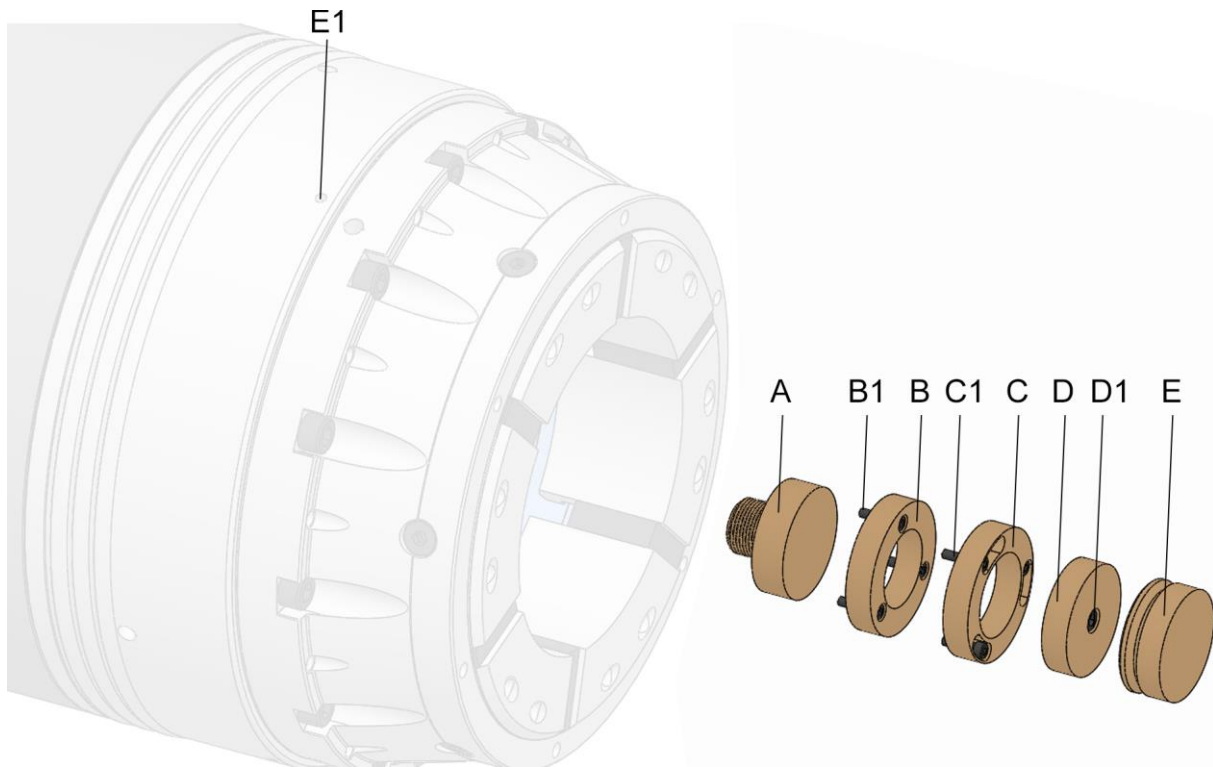

- A Changing part variant direct screw connection
- B Changing part variant x-times axial screw connection
- B1 Fixing screws changing part variant x-times axial screw connection
- C Changing part variant x-times axial screw connection bayonet
- C1 Fixing screws changing part variant x-times axial screw connection bayonet
- D Changing part variant central axial screw connection
- D1 Fixing screw changing part variant central axial screw connection
- E Changing part variant radially clamped
- E1 Clamping screw changing part variant radially clamped

The changing parts, such as the workpiece end-stop, can be installed in different ways.



If necessary, in addition to these operating instructions, you should also read and follow the operating instructions for the relevant changing parts.



INFORMATION

To be able to install the changing part, it may first be necessary to remove the clamping element.

1. As described in the »Preparation of the machine for installation« chapter, prepare for the following steps.
2. Move the clamping device into release position.



INFORMATION

If necessary, the changing part is positioned. Positioning can for example be performed by marks, or a cylindrical pin and a bore or a groove.

7.7.1 Installation of the variant, screwed directly

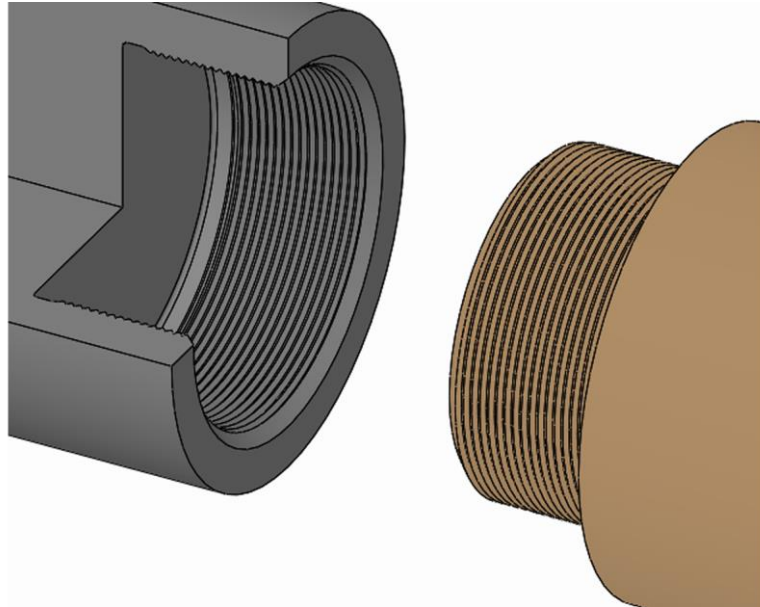

1. Screw the changing part into the product using its thread, and tighten it down.

7.7.2 Installation of the variant x-times with axial screw connection

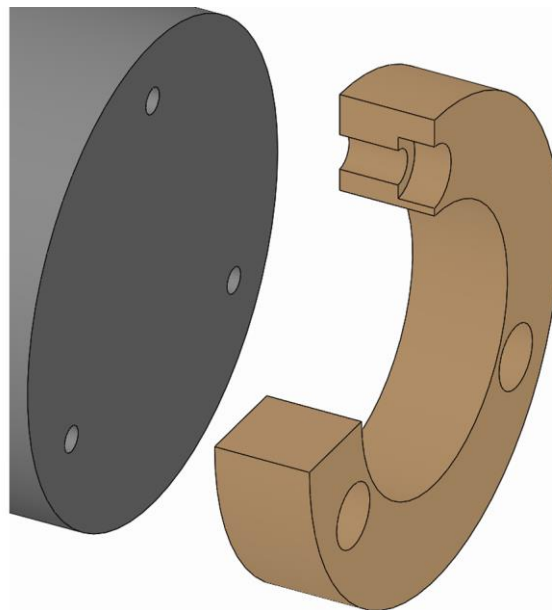

1. Place the changing part onto the product.

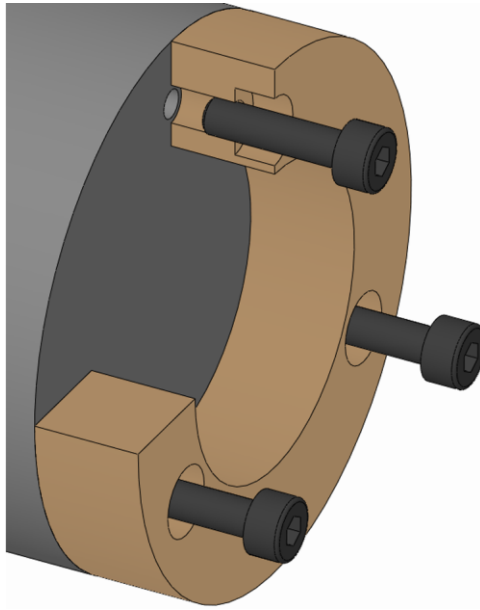

2. Screw in the changing part fixing screws on the changing part and tighten to the specified tightening torque [see »Screw tightening torques« chapter].

7.7.3 Installation of the variant x-times with bayonet axial screw connection



INFORMATION

Initial installation of the changing part with bayonet is in accordance with the variant with an x-times axial screw connection, see »Installation of x-times variant with axial screw connection«.

After initial installation, the changing part fixing screws remain in the clamping device.

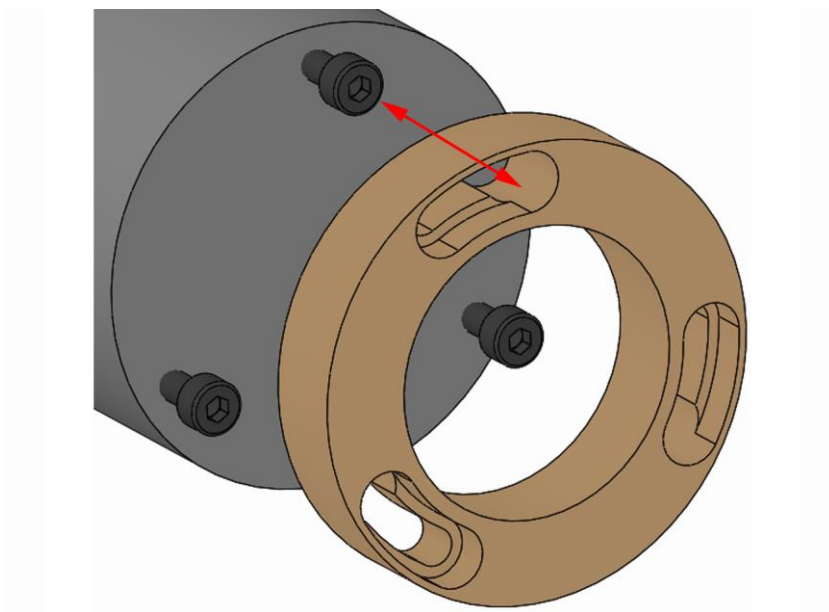

1. Place the changing part on the product so that the screw head on the changing part fixing screw fits through the bayonet opening.

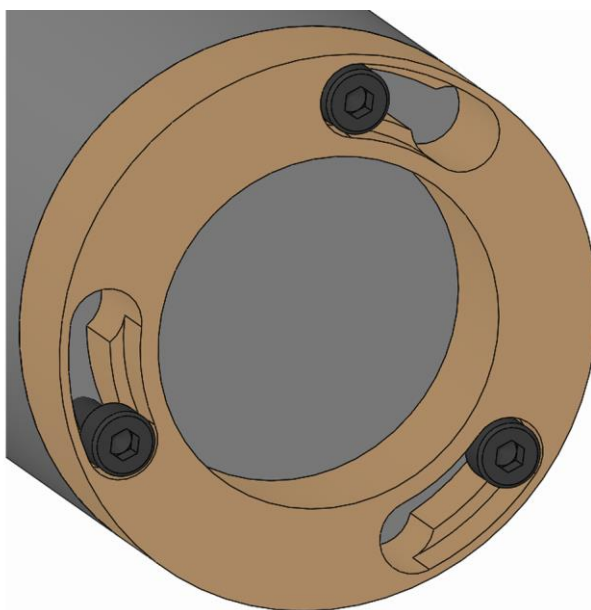

2. Twist the changing part until firmly home.

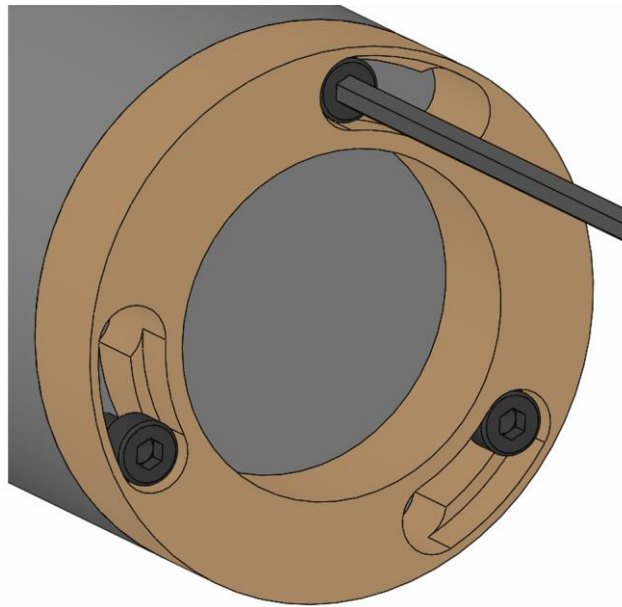

3. Screw in the changing part fixing screws and tighten to the specified tightening torque [see »Screw tightening torques« chapter].

7.7.4 Installation of the central variant with axial screw connection

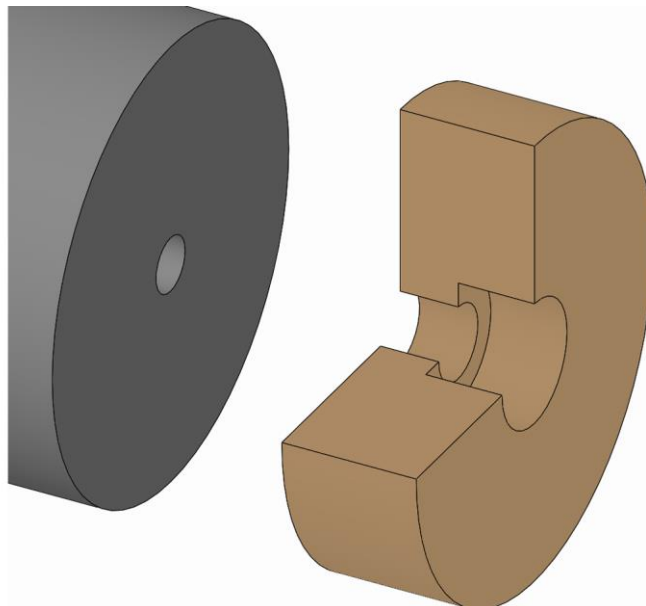

1. Place the changing part into the product.

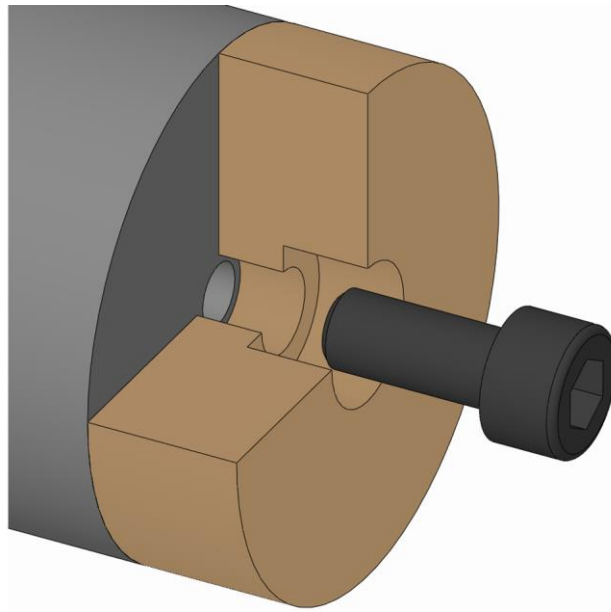

2. Screw in the changing part fixing screw and tighten it to the specified tightening torque [see »Screw tightening torques« chapter].

7.7.5 Installation of the radially clamped variant



INFORMATION

To install / remove the changing part in / from the product, it may be necessary to use a grab handle or an appropriate auxiliary tool.

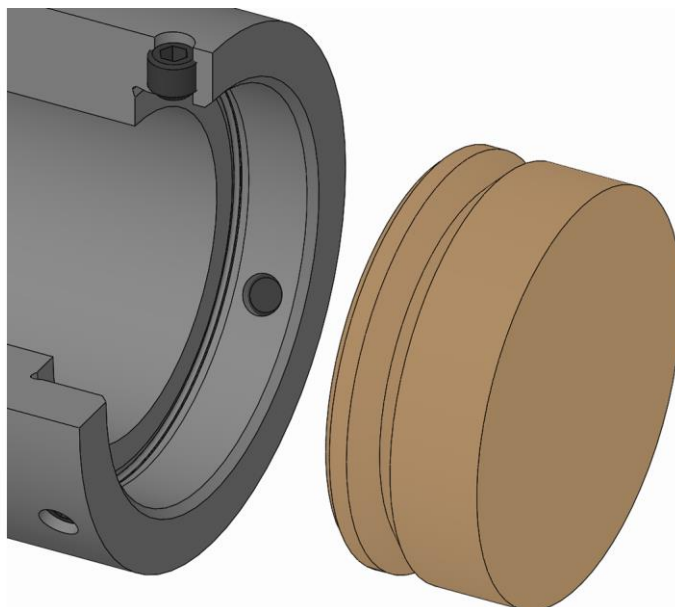

INFORMATION

When installing the changing part, ensure that it gets installed in the right direction to enable the clamping screw on the radially clamped changing part variant to engage in the groove in the changing part.
When installing the base end-stop, the ground side must face forwards.

1. Place the changing part into the product.

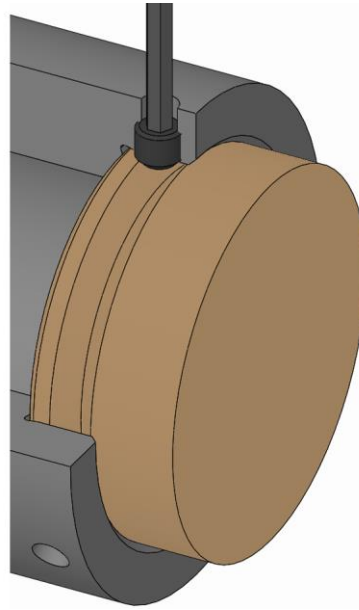

2. Screw in the clamping screws on the changing part and tighten to the specified tightening torque [see Nomenclature].
3. Unfasten and remove the grab handle if used, or the auxiliary tool.

7.8 Aligning the clamping device with the test specimen

To achieve the greatest possible accuracy, the clamping device must be aligned on the workpiece. For this, a test specimen can be used. A test specimen can take the form of a test ring, a test shaft or a test workpiece [this is approximated on the workpiece contour].

To align the clamping device using the test specimen, the functional unit fixing screws must be readily accessible.

1. As described in the »Preparation of the machine for installation« chapter, prepare for the following steps.
2. Install the appropriate clamping element for the test specimen and changing part [see »Installation of clamping element« and »Installation of changing parts« chapters].
3. Clamp the test specimen.
4. Check the axial run-out on a suitable test surface of the test specimen.

Whenever the axial run-out is greater than the maximum permitted value:

5. Unfasten the fixing screws of the functional unit and tighten them gently.
6. Check the axial run-out on a suitable test surface of the test specimen and correct the functional unit if necessary [see alignment procedure from chapter »Installation of the functional unit of an alignable clamping device«].
7. Tighten the fixing screws on the functional unit to the specified tightening torque [see »Screw tightening torques« chapter].
8. Repeat the axial run-out test on the test specimen.

8 Commissioning

For commissioning purposes, set the operating pressure to the permitted, established machining value.

The machine tool must not start up until full operating pressure has built up.

8.1 Commissioning safety



DANGER

Serious injuries caused by workpieces being ejected centrifugally or dropping out if clamping force is insufficient!

- Workpiece blanks must not be outside the clamping width diameter.
- Prior to commissioning, set the actuation force to the permitted, established machining value.
- Clamping of the workpiece must not be outside the defined limits [see »Limits of use« chapter].
- Check the clamping force at regular intervals and correct if necessary.



WARNING

Serious injuries can be caused if the machine tool starts up accidentally!

- Prior to commissioning, close all safety doors or hoods on the machine tool.



WARNING

Serious injuries caused by tools and items of test equipment being ejected centrifugally!

- Prior to commissioning, ensure that all tools and items of test equipment are removed from the working area of the machine.



NOTE

Serious damage to materials / the product caused by workpieces being ejected centrifugally or dropping out if clamping force is insufficient!

- Workpiece blanks must not be outside the clamping width diameter.
- Prior to commissioning, set the actuation force to the permitted, established machining value.
- Clamping of the workpiece must not be outside the defined limits [see »Limits of use« chapter].
- Check the clamping force at regular intervals and correct if necessary.



NOTE

Damage to components caused by cooling lubricants with sufficient levels of corrosion inhibitor!

- The components made of steel materials must be protected before the usual oxidation process.
- Only ever use cooling lubricants with sufficient levels of corrosion inhibitor.



NOTE

Damage to materials caused by contaminated / unprocessed cooling lubricants!

- For the product to function properly, in particular for internal flushing with cooling lubricants and/or when using tools with internal flushing, ensure that the cooling lubricant is cleaned / processed, and that it contains no particles measuring >100 microns [filtered with a mesh width of 100 microns].



NOTE

Damage to seals caused by using the wrong coolant lubricants!

- To clean the product, never use a cooling lubricant that attacks and damages the sealing elements installed. Those installed sealing elements can be made of NBR, Viton and PUR materials.
- Never use cooling lubricants that contain ester or a polar solvent.



NOTE

Damage to clamping elements caused by using the wrong cooling lubricants!

- Never use cooling lubricants that contain ester or a polar solvent.

8.2 Checking the total stroke



WARNING

Serious crushing injuries caused by moving parts when stroke positions are being tested!

- Set the machine into set-up mode.
- Reduce the operating pressure to a minimum.
- Never reach into moving parts.
- Pay attention to the gap dimensions of moving parts.

Prior to commissioning, check the complete stroke to ensure that there is sufficient reserve stroke and opening stroke.

For this, the same measurement of the moving part must be performed at fixed points in front and rear limit positions.

Then deduct the value obtained in the rear limit position from the value obtained from the front limit position. This figure must then be equal to or greater than the nominal total stroke.

For the axial nominal total stroke, the values of axial clamping reserve and axial release stroke must be added together [see »General information« chapter].

8.3 Tests



NOTE

Serious damage to, or destruction of, the machine tool and the workpiece caused by damaged, incomplete or incorrectly installed products!

- Only install undamaged and complete products properly.
- If in doubt, contact the manufacturer.

Assure the following points before every installation and/or before every time the products are put into service:

- The products used are undamaged.
- All fixing screws are present on the products, and are tightened to the correct tightening torque.
- None of the rubber segments on the clamping elements and attachments are torn or exhibit porous areas.
- Serrations and grooved profiles must not be excessively rounded because this would prevent the friction coefficient from being achieved.
- None of the edges and races are chipped or show any signs of wear.
- The speed set on the machine tool must not exceed the maximum speed of the product. Always take the lowest value of all maximum speeds for combined products indicated.
- Pay attention to the level of actuating force established to enable the workpiece to be clamped with sufficient clamping force.
- Do not exceed the maximum actuating force indicated on the product. Always take the lowest value of all actuating forces indicated for combined products.
- All installation tools are removed from the machining area.
- Clamping device and workpiece are compatible - check clamping diameter on a regular basis.
- Conduct a clamping force measurement.

8.4 Workpiece



DANGER

Serious injuries caused by parts being ejected centrifugally if level of workpiece clamping is insufficient!

- Never utilize the full clamping reserve.
- Do not exceed the permitted maximum clamping reserve stroke.
- The remaining clamping reserve must always be adapted to suit the workpiece material provided and its possible distortions.



WARNING

Crushing injuries to hands / fingers if workpiece is installed incorrectly!

- Do not place hands / fingers between workpiece and clamping device.
- Never reach into the clamping area.



CAUTION

Burns caused by high workpiece temperature!

- Give preference to automatic loading.
- Also wear the following items of personal protective equipment, in addition to the basic equipment:



8.5 Procedure after a collision

In the event of a collision, the product and its components must be checked for cracks and damage before being used again.

For this, remove the product from the machine [see »Removal of the product« chapter] and dismantle it [for level of disassembly, see »Cleaning« chapter].

9 Activities after end of production

1. Move product into release position.
2. Switch off machine tool and secure it to prevent it from being switched back on.
3. Open the safety door / hood.



WARNING

Eye injuries and cuts caused by failure to wear protective clothing during cleaning operation!

- Never use compressed air to clean the product.
- Also wear the following items of personal protective equipment, in addition to the basic equipment:



4. Clean the product of swarf and production residue with a soft, lint-free cloth and apply a light coating of oil.
5. Close the safety door / hood.

10 Removal

If a break in production occurs that lasts for more than three days, the product must be removed and stored safely in accordance with the manufacturer's stipulations [see »Transport, packaging, storage« chapter].

10.1 Safe removal



WARNING

Serious injuries caused by unskilled staff during installation / removal!

- Installation and removal must be performed by skilled staff from the relevant specialist field.



WARNING

Serious injuries can be caused if the machine tool starts up accidentally!

- Set the machine tool into set-up mode.
- Remove all tools, auxiliary equipment and items of test equipment immediately from the working area of the machine.
- Remove all lifting gear from the product and from the working area of the machine.



WARNING

Serious injuries caused by the escape of media under high pressure!

- Shut down media delivery during installation and removal.
- Relieve any pressure trapped in the system.
- Shut down the system.



WARNING

Serious crushing injuries and breakages caused by falling parts during incorrect installation or removal!

- Ensure that the product cannot roll away or fall.
- If necessary, use an appropriate mounting aid for installation or removal on a vertically suspended machine spindle.



WARNING

Serious crushing injuries caused by improper machine movement during installation or removal!

- Machine movements are only permitted in set-up mode during installation and removal.
- Never reach into a gap.
- Pay attention to the gap dimensions of moving parts.



WARNING

Serious head injuries caused by bending into the working area of the machine!

- Only ever bend into the working area of the machine if there are no cutting tools or sharp objects in it, or if these are covered.
- Never move body parts under parts in the working area of the machine with the potential to drop down.
- Depending on weight, use an appropriate mounting aid for installation or installing on a vertically suspended machine spindle.



WARNING

High level of physical strain due to the weight of the product or of its components if not transported properly!

- From a weight of 10 kg, use appropriate transport equipment, lifting gear and lifting tackle.



CAUTION

Serious cut injuries caused by sharp-edged changing parts and/or clamping elements!

- All installation / removal of changing parts and clamping elements must be performed by skilled staff from the relevant specialist field.



INFORMATION

If necessary, use any forcing / extraction threads in the components of the product, changing parts or clamping elements.

10.2 Preparing the machine for removal

1. Set the machine into set-up mode.



INFORMATION

The minimum operating pressure is reached when the drawtube can still just be moved without triggering an error message.

2. Reduce the operating pressure to a minimum.
3. Remove cutting tools and/or sharp objects from the working area of the machine, or cover them.
4. Remove operating and auxiliary materials as well as remaining processing materials and dispose of them in an environmentally responsible manner.

10.3 Removal of the changing parts

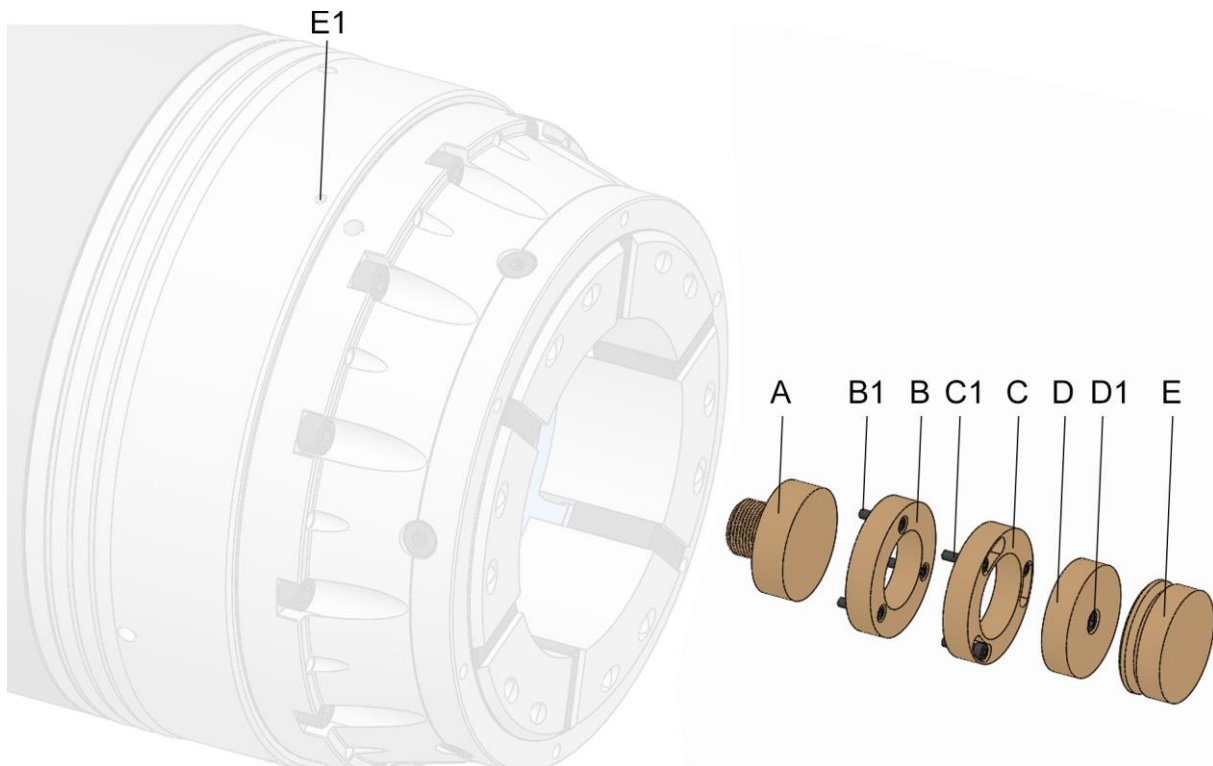

- A Changing part variant direct screw connection
- B Changing part variant x-times axial screw connection
- B1 Fixing screws changing part variant x-times axial screw connection
- C Changing part variant x-times axial screw connection bayonet
- C1 Fixing screws changing part variant x-times axial screw connection bayonet
- D Changing part variant central axial screw connection
- D1 Fixing screw changing part variant central axial screw connection
- E Changing part variant radially clamped
- E1 Clamping screw changing part variant radially clamped

Depending on the version of changing parts, they can be removed as follows.



If necessary, in addition to these operating instructions, you should also read and follow the operating instructions for the relevant changing parts.



INFORMATION

To be able to remove the changing part, it may be necessary to remove the clamping element first.

1. As described in the »Preparing the machine for removal« chapter, prepare for the following steps.
2. Move the clamping device into release position.

10.3.1 Removal of the variant with direct screw connection

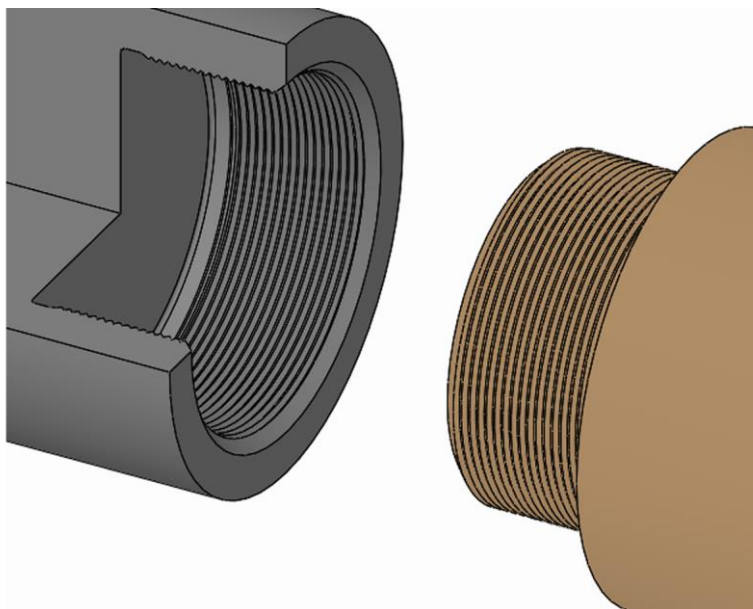

1. Unscrew the changing part from the product using its thread.

10.3.2 Removal of the variant x-times with axial screw connection

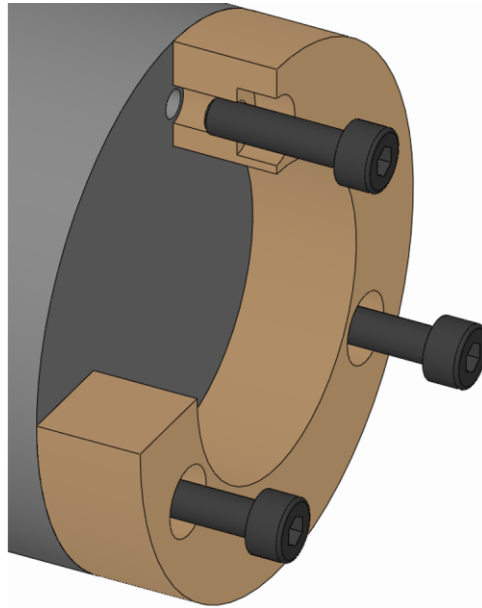

1. Unfasten and remove the fixing screws on the changing part.

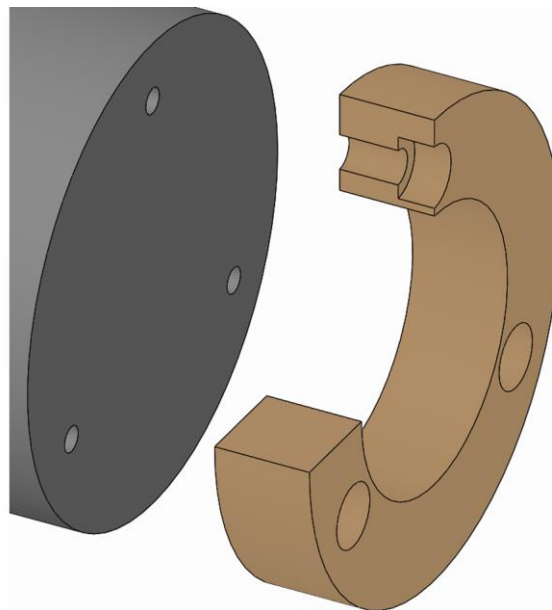

2. Take the changing part off the product.

10.3.3 Removal of the variant x-times with axial screw connection bayonet

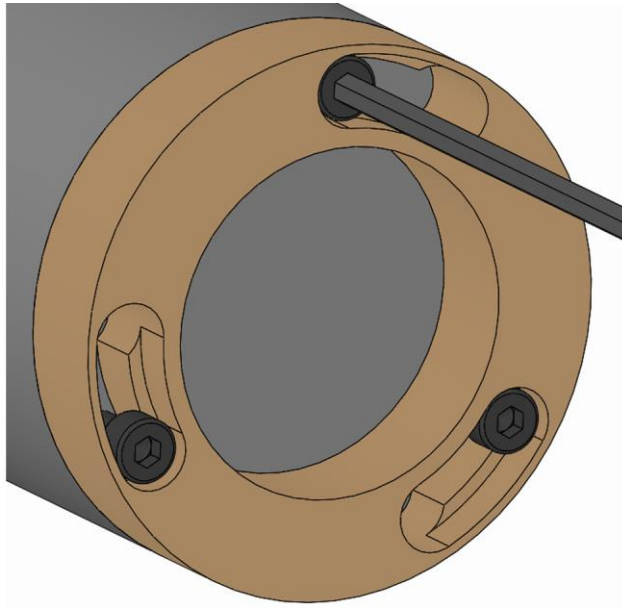

1. Unfasten the fixing screws on the changing body a few turns without removing them.

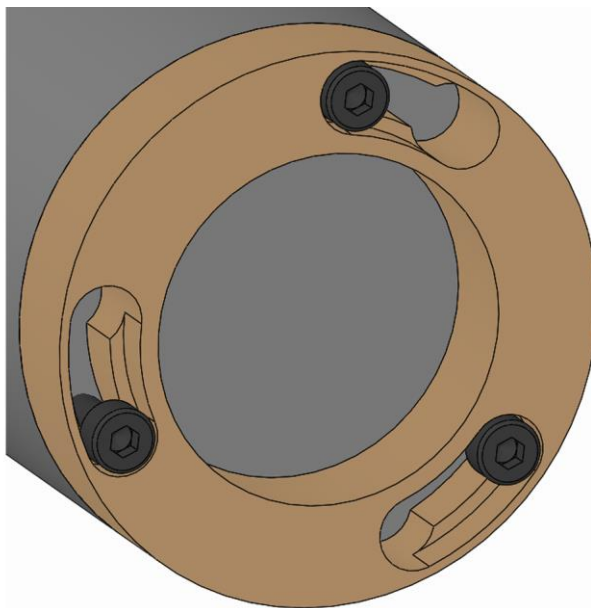

2. Turn the changing part until the screw head on the changing part fixing screw fits through the bayonet opening.

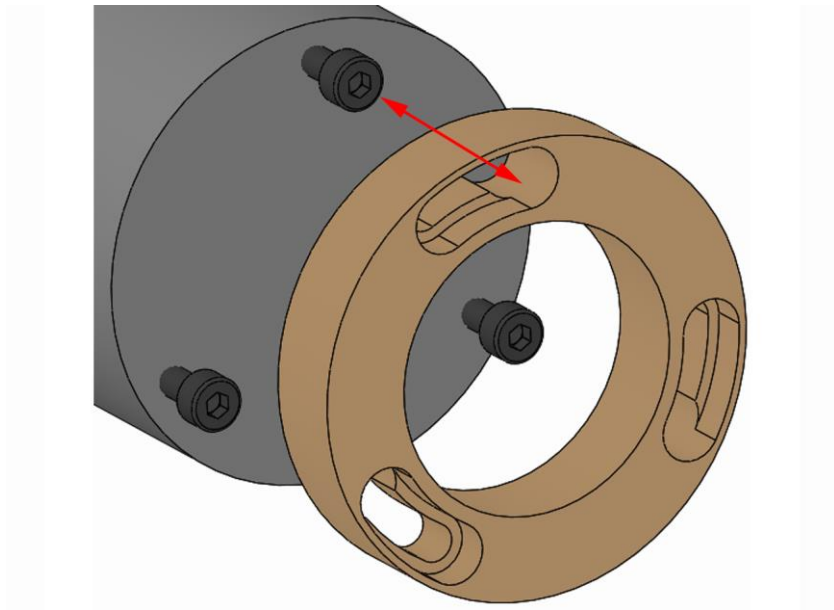

3. Take the changing part off the product.

10.3.4 Removal of the central variant with axial screw connection

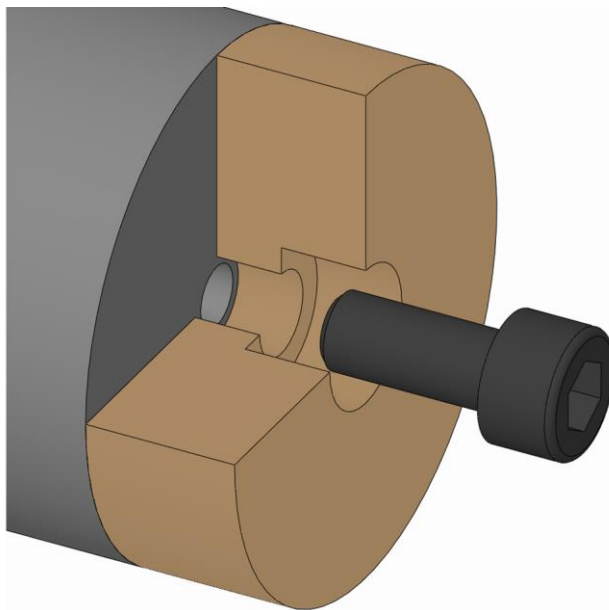

1. Unfasten and remove the fixing screw on the changing part.

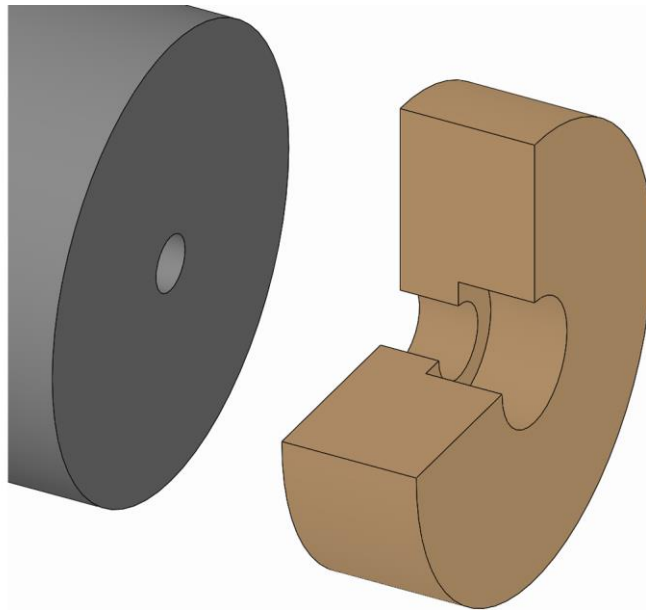

2. Take the changing part out of the product.

10.3.5 Removal of the radially clamped variant



INFORMATION

To install / remove the changing part in / from the product, it may be necessary to use a grab handle or an appropriate auxiliary tool.

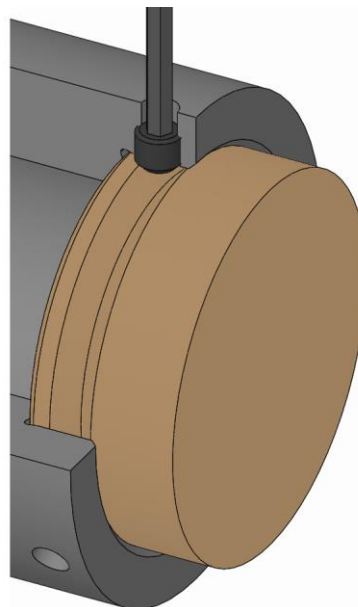

1. Unscrew the clamping screws from the changing part until the changing part can be lifted out.

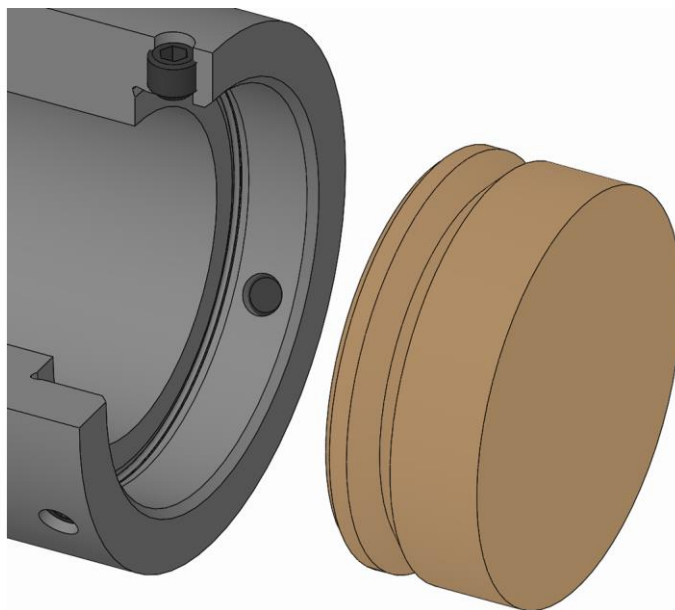

2. Take the changing part out of the product.

10.4 Removal of the clamping element

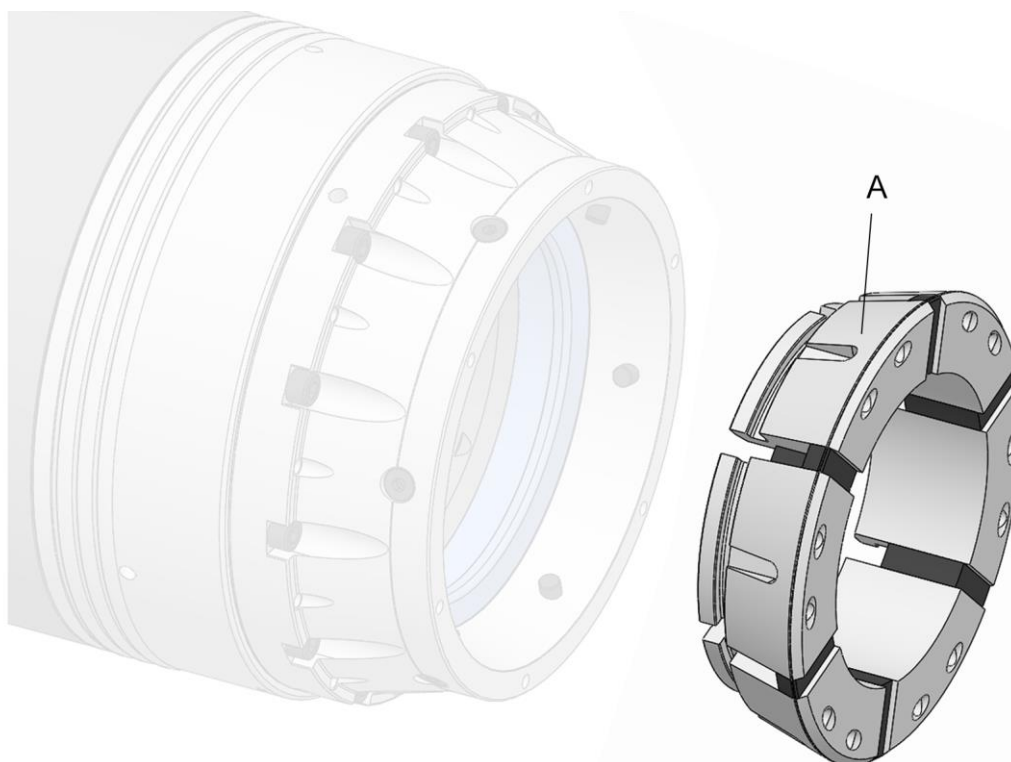

A Clamping head [clamping element]

Special aids needed:

■ Changing fixture

1. As described in the »Preparing the machine for removal« chapter, prepare for the following steps.
2. Move the clamping device into release position.

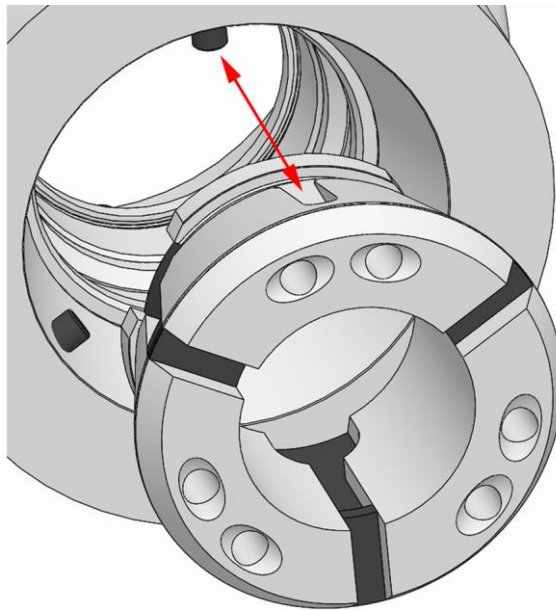

WARNING

Serious crushing injuries caused by reaching into the coupling / slot area in the clamping head or into the changing fixture!

- During actuation, never reach into the coupling / slot area in the clamping head or into the changing fixture.

3. Remove the clamping head from the product with an appropriate changing fixture.

10.5 Removal of the product

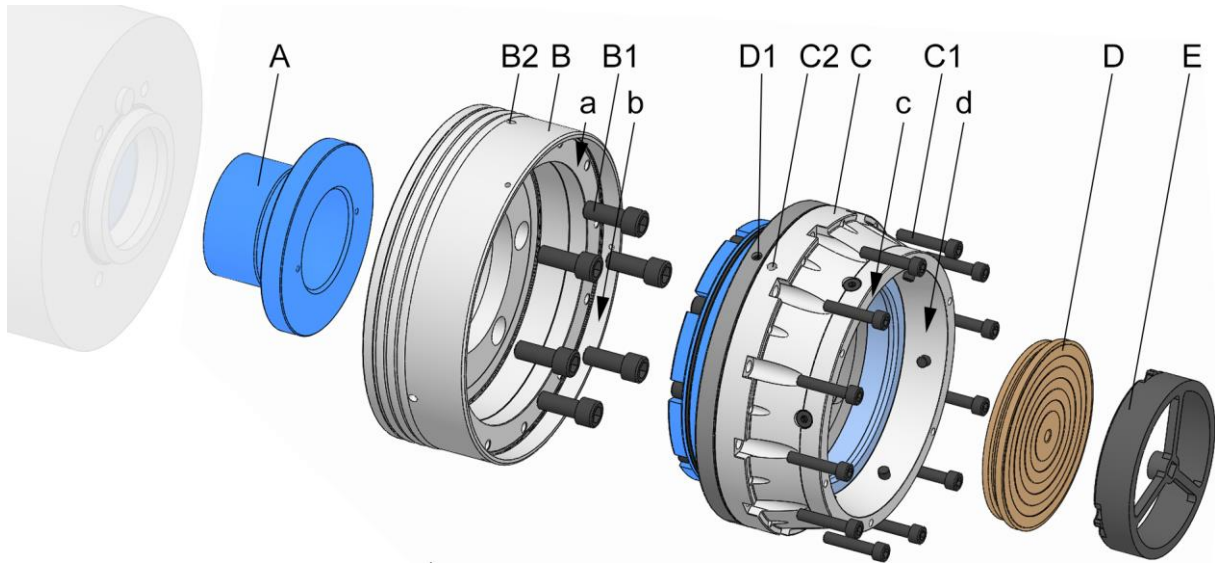

- A Drawtube adapter
- B Spindle flange
- B1 Fixing screws, spindle flange
- B2 Transport thread spindle flange
- C Functional unit
- C1 Fixing screws functional unit
- C2 Transport thread functional unit
- D Base end-stop
- D1 Clamping screw base end-stop
- E Assembly wrench adapter
- a Test surface face run-out spindle flange
- b Test surface axial run-out spindle flange
- c Test surface face run-out functional unit
- d Test surface axial run-out functional unit

Special aids needed:

- Assembly wrench adapter
1. As described in the »Preparing the machine for removal« chapter, prepare for the following steps.

10.5.1 Removal of the functional unit



INFORMATION

Before removing the functional unit, the base end-stop needs to be removed [see »Removal of the changing parts« chapter].

1. Attach any lifting gear that may be required.
2. If necessary, fit the mounting aid onto a vertically suspended spindle.
3. Move the machine drawtube to its rear limit stop.

SPANNTOP mini pull-back Removal

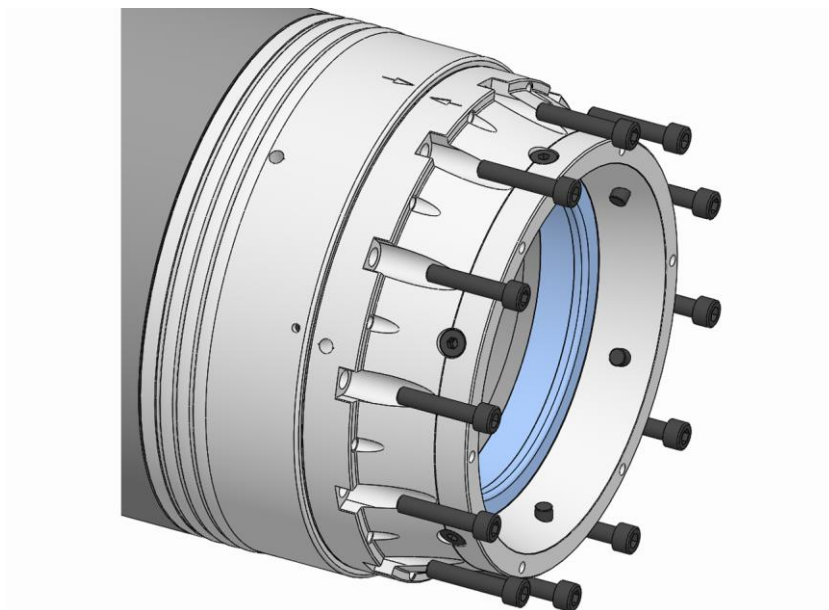

4. Unfasten and remove the fixing screws on the functional unit.
5. Using the least possible force and speed, move the drawtube on the machine to its front limit stop [see »Preparing the machine for removal« chapter].

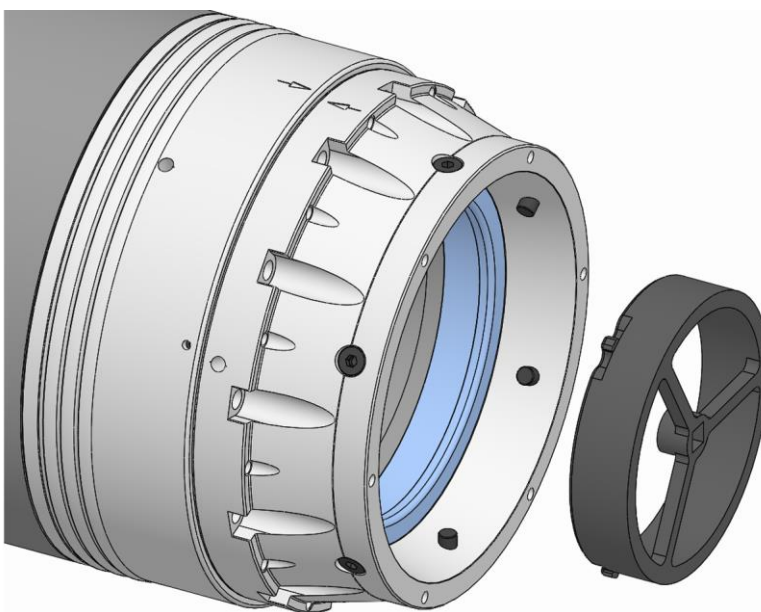

6. Install the mounting aid in the functional unit to enable the mounting aid to engage in the grooves of the drawtube adapter in the functional unit.

SPANNTOP mini pull-back Removal

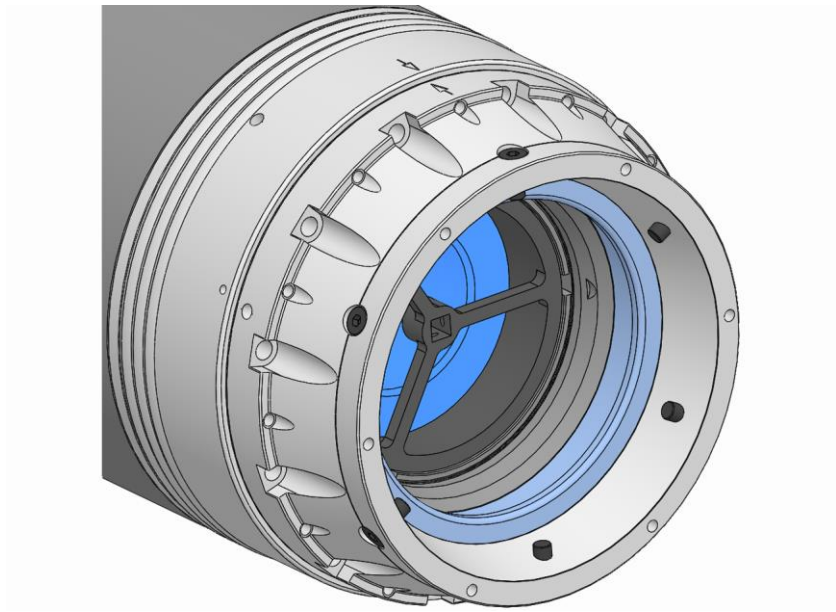

7. Using the mounting aid, unscrew and remove the draw-tube adapter on the functional unit from the machine drawtube.

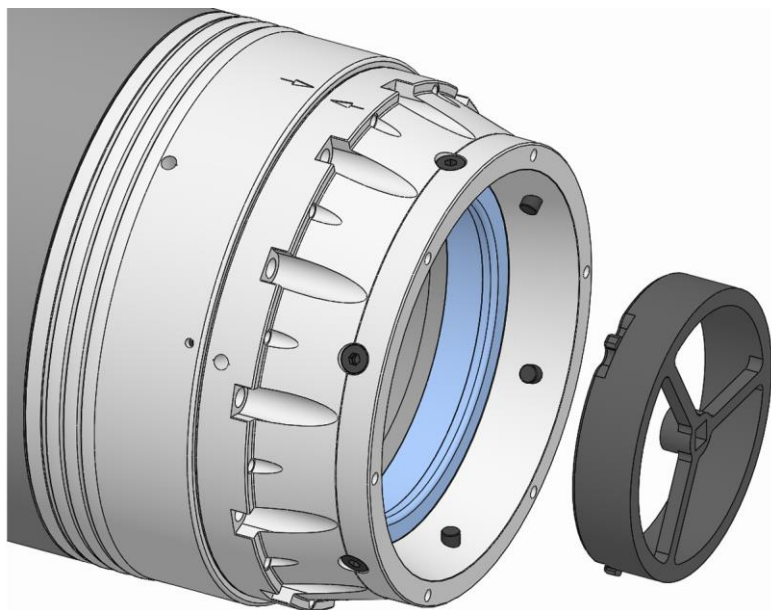

8. Remove the mounting aid from the functional unit.

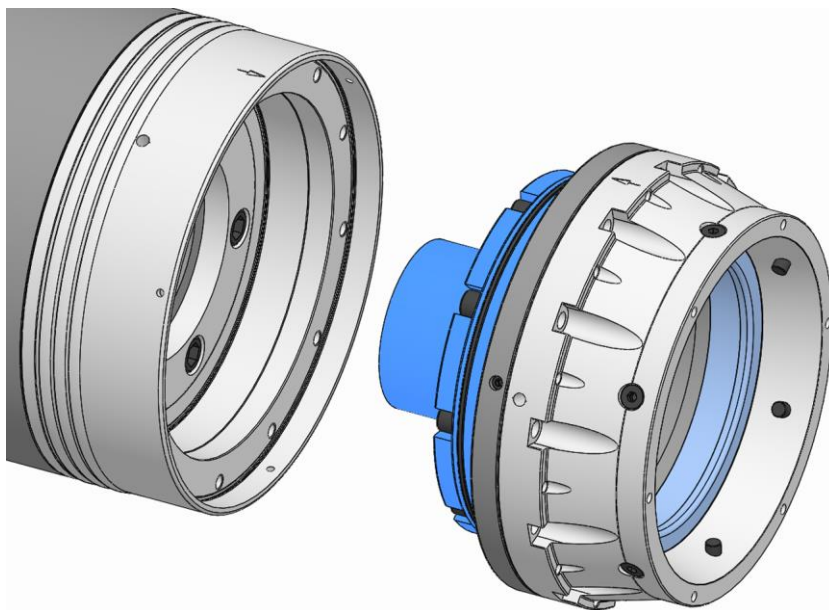

9. Take down the functional unit from the spindle flange.

10.5.2 Removal of the spindle flange

1. Attach any lifting gear that may be required.
2. If necessary, fit the mounting aid onto a vertically suspended spindle.

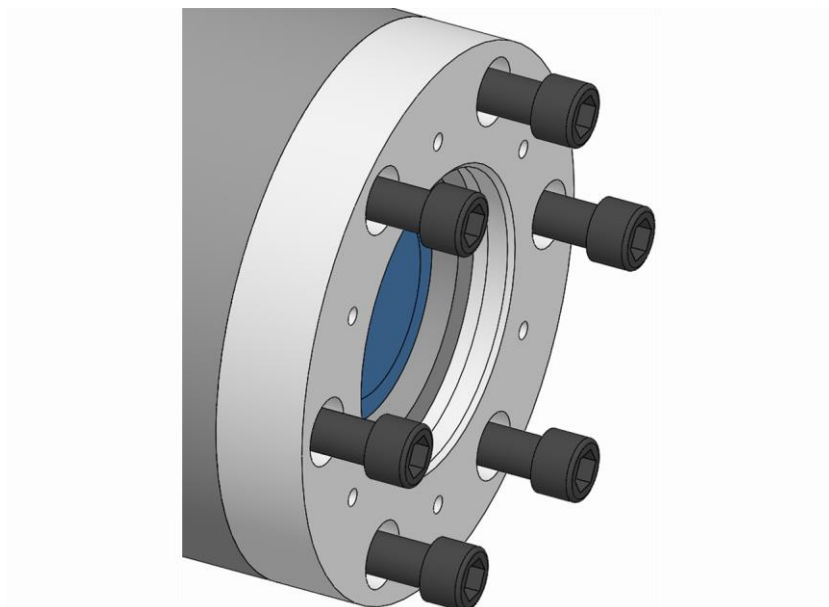

3. Unfasten and remove the fixing screws on the spindle flange.

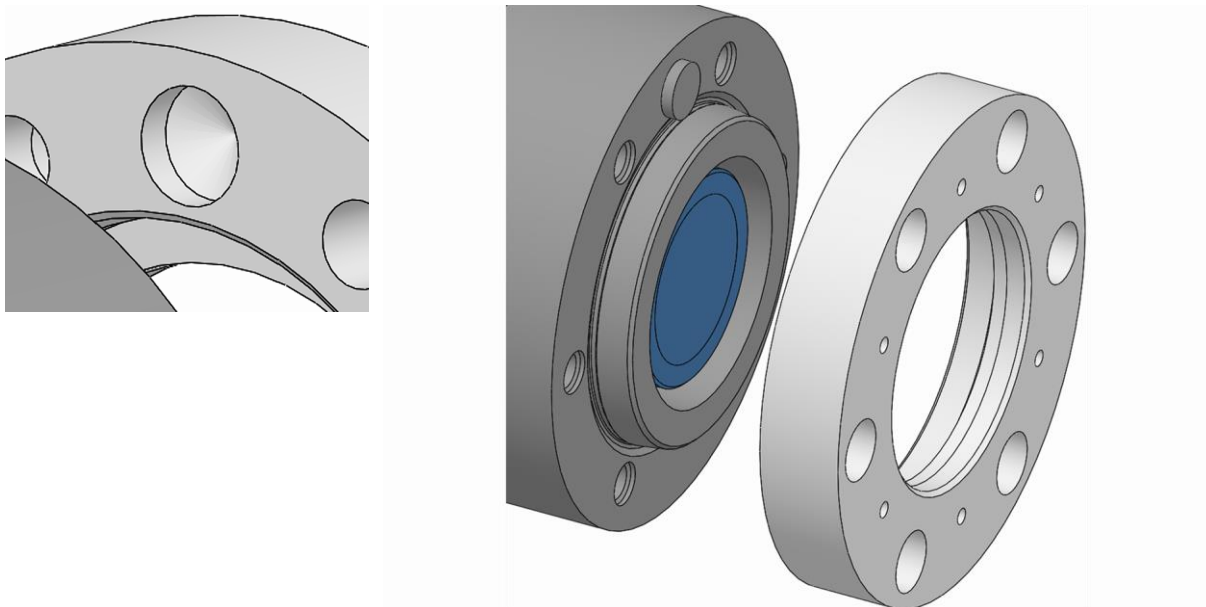

4. Take down the spindle flange from the machine spindle.

10.5.3 Removal of the drawtube adapter

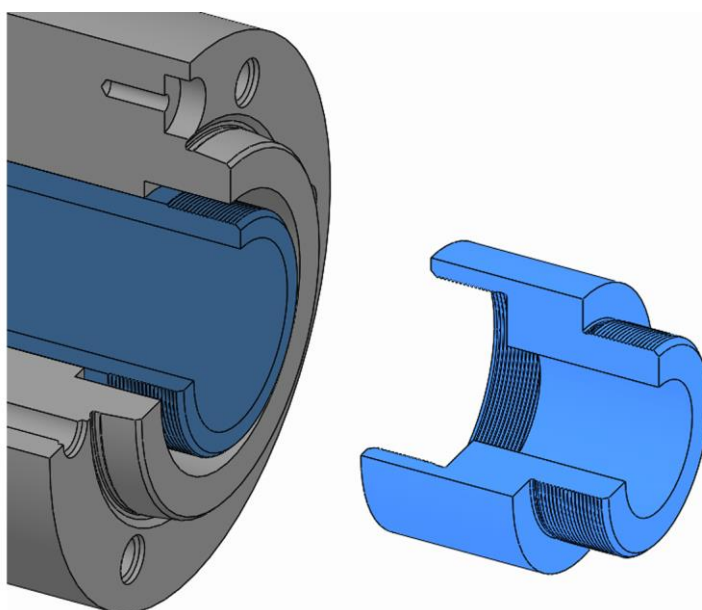

1. If the drawtube adapter was mounted on the machine drawtube, use its thread to unscrew and remove it from the machine drawtube.

11 Maintenance

11.1 Maintenance safety



WARNING

Serious injuries caused by parts being ejected centrifugally after a loss of clamping power!

- Maintain the maintenance and cleaning intervals of the product at all times.
- It is essential to check the maintenance status of the product at regular intervals with a structural clamping force measurement.



CAUTION

Health risks caused by incorrect handling of cleaning agents!

- Pay attention to hazard specifications and the safety data sheet of the manufacturer.



INFORMATION

If necessary, use any forcing / extraction threads in the components of the product, changing parts or clamping elements.

11.2 Maintenance schedule

The following sections describe the maintenance work needed to ensure optimum and fault-free operation.

If increased levels of wear are detected during regular checks, shorten the maintenance intervals to reflect the actual rate at which signs of wear appear.

Contact the manufacturer for questions relating to maintenance work and maintenance intervals [see »Contact« chapter].

SPANNTOP mini pull-back Maintenance

Interval	Maintenance work
daily	Visual inspection of clamping and mating surfaces for signs of wear, nicks and cracks [see »Visual inspection« chapter]
	Visual inspection of rubber on clamping element for signs of wear, nicks and cracks [see »Visual inspection« chapter]
	Complete cleaning if heavily soiled [see »Cleaning« chapter]
	Conduct a structural clamping force measurement
weekly or after 40- operating hours*	Remove the clamping element [see »Removal of the clamping element« chapter]
	Clean the clamping element, clamping taper and coupling area [see »Cleaning« chapter]
six-monthly or after 1500 operating hours*	Completely clean the product [see »Cleaning« chapter]
	Lubricate the product [see »Lubricating the product« chapter]
with storage	See »Storage« chapter

* depending upon which stipulation is achieved first

Table 18: Maintenance table

11.3 Cleaning

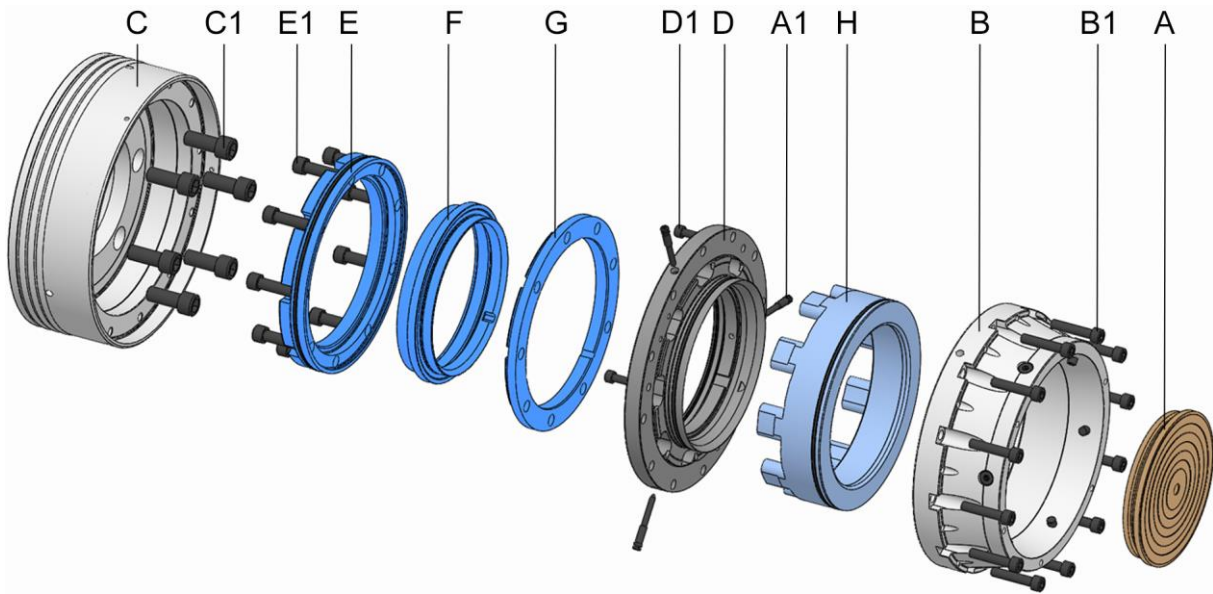

- A Base end-stop
- A1 Clamping screw base end-stop
- B Clamping element receiver
- B1 Fixing screws clamping element receiver
- C Spindle flange
- C1 Fixing screws, spindle flange
- D Centering disc
- D1 Fixing screws centering disc
- E Ring
- E1 Ring fixing screws
- F Adapter
- G Disc
- H Coupling



WARNING

Eye injuries and cuts caused by failure to wear protective clothing during cleaning operation!

- Never use compressed air to clean the product.
- Also wear the following items of personal protective equipment, in addition to the basic equipment:





NOTE

Damage to seals caused by the wrong solvent!

- To clean the product, never use a solvent that attacks and damages the sealing elements installed. Those installed sealing elements can be made of NBR, Viton and PUR materials.
- To clean the product, never use a solvent that contains ester, nor a polar solvent.



NOTE

Damage to clamping elements caused by the wrong solvent!

- To clean the product, never use a solvent that contains ester, nor a polar solvent.



NOTE

Damage to materials caused by incorrect installation of sealing elements!

- Replace missing or damaged sealing elements.
- Ensure that the sealing elements do not fall out or get damaged during installation / removal, and apply a thin coat of grease if necessary.

Cleanliness of the relevant limit stop and guide diameter are essential for achieving axial and face run-out tolerances.

1. Remove the changing parts and the clamping element from the product [see »Removal of changing parts« and »Removal of clamping element« chapters].
2. Remove the product from the machine [see »Removal of the product« chapter].



WARNING

Serious injuries caused by imbalance resulting from incorrect reassembly!

- The product components must be installed back in the same position.
- If necessary, mark out the relative positions of components prior to disassembly.



NOTE

Damage to materials caused by incorrect Removal of the product!

- More extensive disassembly than shown on the exploded drawing is prohibited.

3. Dismantle the product as shown on the exploded drawing. Pay attention to the following during disassembly:
 - To separate the centering disc from the clamping element receiver, using forcing threads if necessary.
4. Clean all oil and grease residues off all components with an ester-free, non-polar, soft, lint-free cloth and check for visible signs of damage.
5. Assemble the product in accordance with the exploded drawing and lubricate during assembly [see »Lubricating the product« chapter]. Pay attention to the following during assembly:
 - There must not be any gap between the centering disc and the clamping element receiver after the joining process.
 - Replace worn or damaged fixing screws.
 - Tighten all fixing screws to the specified tightening torque [see nomenclature and/or »Screw tightening torques« chapter]. When tightening the screws, do so evenly to prevent any distortion under load.
 - Only apply lubricant to the mechanical mating surfaces. Pay attention to notes about lubricants [see »Use of lubricants« chapter].
 - Avoid too much lubricant on the locating face because this can cause face run-out errors.
 - Apply grease to the sealing elements [for example O-rings, rectangular rings] and sealing surfaces. Pay attention to notes about greases [see »Use of lubricants« chapter].
 - Align the washer with the clamping taper [ideally ≤ 0.01 mm].

11.4 Visual inspection

Perform a daily visual inspection of the product to identify any damage to the product at an early stage.

Check the product for cracks and damage, in particular on the clamping and end-stop surfaces.

The rubber on the clamping element also needs to be examined for cracks and signs of damage.

A check is also required to ensure that all fixing screws are tightened down.

If damage is detected, the relevant components must be exchanged immediately for genuine spare parts from the manufacturer.

Complete cleaning of the product is required if heavily soiled [see »Cleaning« chapter].

11.5 Lubricating the product



DANGER

Serious injuries caused by workpiece being ejected centrifugally due to insufficient lubrication of the product!

- Never drop below the lower limit value for clamping force [see »Clamping force diagram« chapter].
- Always comply with the maintenance intervals [see »Maintenance schedule« chapter].

Lubrication takes place every time the system is cleaned, maintained or assembled, and also when required.

1. Dismantle the product for lubrication purposes. Consult the »Cleaning« chapter for details of the level of disassembly required.
2. At all lubrication points, remove escaping, consumed or surplus grease, and dispose of it in accordance with locally enforceable legislative provisions.
3. After lubrication, perform the entire stroke several times.

11.6 Use of lubricants

To achieve ultimate performance from the products, use the specified lubricants.

Only use grease that complies with the fundamental requirements governing adhesion, pressure resistance and solubility in coolants. Furthermore, there must be no particles of dirt in the grease because these cause an operational malfunction if they come between two interference fit surfaces. For this, the following lubricants are recommended:

GP 355 universal grease

[see the HAINBUCH product catalogue]

Alternatively:

Lubricants	Manufacturer	Product designation
Grease	MicroGleit	GP 355
	Klüber	QNB 50
	Zeller & Gmelin	DIVINOL SD24440
	Bremer & Leguill	RIVOLTA W.A.P.

Table 19: Selection of lubricants



NOTE

Malfunction of the product due to a combination of different greases!

- Never mix different greases with one another.
- Clean the product completely before using a different grease.

12 Disposal

If no agreement exists for return or disposal, send dismantled components off for recycling.



NOTE

Substantial damage to the environment can result from incorrect disposal of environmentally hazardous substances!

- Products containing composites [mineral casting, CFK] must be returned to HAINBUCH for disposal.



NOTE

Substantial damage to the environment can result from incorrect disposal of environmentally hazardous substances!

- Lubricants, auxiliary materials and operating fluids are governed by legislation for the processing of special-category waste: All disposal to be performed by authorized waste disposal specialists.

Catch exchanged oils and greases in suitable containers and dispose of them in accordance with applicable local provisions.

The local municipal authority or specialist waste disposal companies can provide information about environmentally compliant disposal.

13 Faults

The following chapter describes possible causes for faults, and the work involved in remedial action.

If multiple faults occur, shorten the maintenance intervals in accordance with actual load levels.

Contact the manufacturer if faults occur that cannot be remedied by following these instructions [see »Contact« chapter].

13.1 Procedure with faults

This applies in all cases:

1. With faults that constitute an immediate danger to people or capital equipment, press the Emergency Stop button on the machine tool immediately.
2. Establish the cause of the fault.
3. If troubleshooting requires work to be conducted in the danger area, switch the machine tool into set-up mode.
4. Notify the person on location of the fault immediately.
5. Depending on the type of fault, get it remedied by authorized and appropriately skilled specialists.



INFORMATION

The troubleshooting table in the following section provides information about who is authorized to remedy a given fault.

6. In the event of a fault not caused by the product, the fault may be caused by something close to the machine tool. For this, refer to the operating instructions of the machine tool.

13.2 Fault table

Fault	Possible cause	Remedial action	Remedied by
Defective axial strokes in the clamping device	Dirt in the parts in the power flow	Remove and clean the clamping element and, if necessary, remove, dismantle and clean the clamping device	Skilled specialist
	Defective drawtube adapter	Discussion with the manufacturer	Manufacturer
	Incorrect drawtube position	Check drawtube position and align with the clamping device	Skilled specialist
Clamping element cannot be swapped in or out	Defective axial strokes in the clamping device	See fault »Defective axial strokes in the clamping device«	
Clamping force is too weak	Workpiece outside the clamping width diameter	Use a suitable clamping element	
	Axial actuating force on drawtube too weak	Check machine setting and correct if necessary	Skilled specialist
	Stroke limitation by the workpiece end-stop	Use an appropriate workpiece end-stop	
Clamping force is too high	Axial actuating force on drawtube too high	Check machine setting and correct if necessary	Skilled specialist
Geometry deviation on the workpiece	Axial run-out error on the clamping device	Check axial run-out of the clamping device and correct if necessary	
	Face run-out error of the clamping device	Check face run-out of the clamping device and clean the mating surfaces if necessary	
	Dirty end-stop area	Remove the workpiece end-stop and clean the mating surfaces	Skilled specialist
	Dirty coupling area in the clamping element	Remove the clamping element, clean the coupling area and the clamping element	
	Dirty clamping taper	Remove the clamping element and clean the clamping taper	
Geometry error on the workpiece due to incorrect type of clamping element	Use a suitable clamping element		

Fault	Possible cause	Remedial action	Remedied by
	Elastic distortion	Reduce the clamping force to the level applicable for the clamping device and the workpiece <hr/> Check the workpiece material	
	Clamping force is too high	Reduce the clamping force to the level applicable for the clamping device and the workpiece	
	Incorrect type of clamping element	Use a suitable clamping element	
Indentations on the clamping surface	Dirty clamping element	Clean the clamping element	Skilled specialist
	Damaged clamping element	Replace the clamping element	
	Dimensional difference between workpiece diameter and clamping bore is too big	Use clamping element with a suitable clamping diameter	

Table 20: Fault table

13.3 Commissioning after a fault has been remedied

After the fault has been remedied, perform the following steps to recommission it:

1. Reset the emergency stop equipment.
2. Acknowledge the fault on the control unit of the machine tool.
3. Ensure that no-one is in the danger area.
4. Start the machine tool.

14 Annex

14.1 Contact

The following hotlines are available to you for orders, schedule tracking and emergencies.

Order hotline

Ordered quickly, supplied swiftly. Just phone:

+49 7144. 907-333

Tracking hotline

Current status of your order? Just call:

+49 7144. 907-222

24 hour emergency phone line

Has a system crash occurred, or some other technical emergency?

Our experts are there for you around the clock:

+49 7144. 907-444

For advice or help, you can contact the sales partners and service staff listed in www.hainbuch.com.

14.2 Manufacturer certification

Manufacturer certification is supplied with the product and with this manual.

Index directory

A		Limits of use	29
Accessories, optional		Lubricants.....	21, 112
MANDO Adapt.....	27	M	
Accessories, required		Maintenance schedule	106
Clamping head	27	Misuse.....	14
Drawtube adapter	27	O	
Workpiece end-stop.....	27	Operating conditions	25
Accessories, special aids		P	
Assembly wrench.....	28	Packaging	52
Pneumatic changing fixture	28	Performance values	22
Accessories, spindle flange required	27	Personnel requirements	12
B		Electricians.....	13
Balancing quality.....	23	Hydraulics specialist	13
Brief description	26	Pneumatics specialist	13
C		Skilled specialist.....	13
Checking the total stroke	87	Trainees	13
Cleaning.....	108	Preservation	53
Copyright	9	Protective equipment	
D		Hair net	16
Definition of terms	8	Hard hat	16
E		Protective gloves.....	16
End of production.....	90	Protective goggles	16
Environmental protection	21	Safety footwear	16
F		Workplace clothing.....	16
Fault table	115	R	
Faults	114	Removal	
H		Clamping element.....	99
Hazards	17	Preparation of the machine	93
I		Product.....	101
Installation		Spindle flange	104
Changing part	76	Removal of changing parts.....	93
Clamping element.....	74	S	
Preparation of the machine.....	58	Safety	
Preparation of the product	60	Commissioning	85
Product	59	General	11
Installation of spindle flange.....	63, 65	Maintenance	106
Installation safety	54	Removal.....	91
Intended use	14	Transport, packaging, storage	50
K		Scope of delivery.....	9
Key to symbols.....	7	Screw tightening torques	
L		Aluminum components.....	57
Layout	26	Metric control threads	57
Liability.....	9	Screw plugs	58

Spare parts	10	Transportation, internal	52
Speed	23	Type designation	25
Storage	53	U	
Symbols on the packaging	51	Unpacking	52
T		Use	29
Technical data	22	W	
Tests	88	Warranty	10
Transport inspection	51		



HAINBUCH GMBH · SPANNENDE TECHNIK

Postfach 1262 · 71667 Marbach / Erdmannhäuser Strasse 57 · 71672 Marbach · Germany

Tel. +49 7144.907-0 · Fax +49 7144.18826 · verkauf@hainbuch.de · www.hainbuch.com

24 hour emergency phone line + 49 7144.907-444

01.2024 · 012.01/0121 EN · Technical modifications reserved