

Operating instructions

[incl. installation manual]

Monteq

Size S / M

EN

Translation of the original operating instructions

Contents

- 1 General..... 6
 - 1.1 Information about this manual..... 6
 - 1.2 Key to symbols..... 6
 - 1.3 Definition of terms 7
 - 1.3.1 Release setting..... 7
 - 1.3.2 Complete clamping reserve 7
 - 1.4 Limitation of liability 8
 - 1.5 Copyright..... 8
 - 1.6 Scope of delivery 8
 - 1.7 Spare parts and accessories..... 9
 - 1.8 Warranty terms 9
- 2 Safety 10
 - 2.1 Responsibility of the operator..... 10
 - 2.2 Personnel requirements..... 10
 - 2.3 Intended use 12
 - 2.4 Personal protective equipment..... 13
 - 2.5 Particular hazards 14
 - 2.6 Other safety instructions 15
 - 2.7 Screws 15
 - 2.8 Functionality..... 16
 - 2.9 Environmental protection 16
- 3 Technical data 17
 - 3.1 General information..... 17
 - 3.2 Performance values 17
 - 3.3 Operating conditions 17
 - 3.4 Type designation..... 18
- 4 Layout and function 19
 - 4.1 Overview and brief description 19
- 5 Use and limits of use 20
 - 5.1 Use..... 20
 - 5.2 Limits of use..... 20
- 6 Transport, packaging, storage 21
 - 6.1 Safety, transport, packaging, storage 21
 - 6.2 Symbols on the packaging 22
 - 6.3 Transport inspection..... 22
 - 6.4 Unpacking and internal transportation..... 23
 - 6.5 Packaging 23
 - 6.6 Storage 24
 - 6.7 Preservation..... 24
 - 6.8 Return to storage 24
- 7 Use 25

7.1	Use-related safety	25
7.2	Preparation of machine for use	26
7.3	Installation of the quick change-over unit	26
7.4	Removal of the quick change-over unit	32
7.5	Tests	36
7.6	Exceptional inspection	36
8	Maintenance	37
8.1	Maintenance safety	37
8.2	Maintenance schedule	37
8.3	Inspection.....	38
8.4	Cleaning.....	38
8.5	Visual inspection	39
8.6	Lubricating the product.....	39
9	Disposal.....	40
10	Faults.....	41
10.1	Procedure with faults.....	41
10.2	Fault table	42
10.3	Commissioning after a fault has been remedied	42
11	Annex	43
11.1	Contact.....	43
11.2	Conformity declaration	43

Directory of tables

Table 1:	Technical data	17
Table 2:	Operating conditions	17
Table 3:	Fault table.....	42

1 General

1.1 Information about this manual

This manual enables you to work safely and efficiently with the product.

This manual is part of the product and must be kept in a location directly beside the product that is accessible to the personnel at all times. The personnel must have read this manual carefully and understood its contents before starting any work. The basic requirement for safe work is compliance with all stipulated safety notices and work-related instructions in this manual.

If the product is passed onto a third party, this manual must accompany it.

Illustrations in this manual are there to facilitate a basic understanding, and may differ from the actual design configuration of the product.



WARNING

Serious injuries caused by individual products or by inappropriate combinations of them!

- Read and pay attention to all operating instructions for individual products and combinations of them.

1.2 Key to symbols

Safety instructions in this manual are designated by symbols. The safety notices are invoked by signal words that express the level of hazard involved.

Always comply with safety notices and exercise caution to avoid accidents, injury to people and damage to materials.

Safety notices



DANGER

... indicates an immediate and hazardous situation that can lead to death or serious injury if not avoided.



WARNING

... indicates a potentially hazardous situation that can lead to death or serious injury if not avoided.



CAUTION

... indicates a potentially hazardous situation that can lead to moderate or slight injuries if not avoided.



NOTE

... indicates a potentially hazardous situation that can lead to damage to materials if not avoided.

Tips and recommendations



INFORMATION

... highlights useful tips and recommendations as well as information for efficient and problem-free operation.



... refers to other documents relating to personal and general safety.

Warning symbols may appear on the product or its components.

Always pay attention to warning symbols, and exercise caution to avoid accidents, injury to people and damage to materials.



... warns of stored energy [for example involving springs].



... warns of hand injuries.



... draws attention to the fact that the operating instructions of the product must be read.

1.3 Definition of terms

1.3.1 Release setting

Release setting means that the clamping device is released. If the clamping device is released, this also releases the workpiece.

1.3.2 Complete clamping reserve

Complete clamping reserve means that the clamping device is clamped without a workpiece. The complete stroke has been used up, which means that the clamping device is therefore at the limit position for clamping reserve.

1.4 Limitation of liability

All details and notices in this manual were compiled with due reference to applicable standards and specifications, state-of-the-art technology and our many years of expertise and experience.

The manufacturer accepts no liability for damage arising from any of the following:

- Non-compliance with this manual
- Unintended use
- Use of untrained personnel
- Autonomous conversion work
- Technical modifications
- Use of non-approved spare parts
- Use of non-approved accessories

Subject to any commitments agreed to in the supplier contract, the General Terms & Conditions of Business and the delivery terms of the manufacturer and all legislative stipulations valid at the time of conclusion of this contract.

1.5 Copyright

This manual is protected by copyright, and are only intended for internal use.

The dissemination of this manual to third parties, reproductions in any shape or form - even in part - as well as commercial use and/or communication of their contents are prohibited for anything other than internal use, except with the written consent of the manufacturer.

Infringements oblige the offending party to pay compensation. Without restriction on further claims.

1.6 Scope of delivery

The scope of delivery of this product includes:

- Monteq
- The operating instructions

1.7 Spare parts and accessories



WARNING

Serious injuries can be caused by incorrect or defective spare parts!

- Always use genuine spare parts made by the original manufacturer.



NOTE

Damage, malfunctions or total failure of the product or the machine tool caused by an incorrect or defective spare parts!

- Always use genuine spare parts made by the original manufacturer.

Spare parts and accessories can be sourced from contract dealers or directly from the manufacturer [see »Contact« chapter].

Without exception, wearing parts and components in contact with the workpiece are not covered by warranty.

1.8 Warranty terms

The warranty terms are included in the manufacturer's General Terms & Conditions of Business.

2 Safety

This section provides an overview of all the important safety aspects for optimum protection of personnel, and for safe and problem-free operation.

2.1 Responsibility of the operator

The product is used in the industrial sector. The operator of the product is therefore governed by the provisions of Health & Safety at Work legislation.

As well as the safety notices in this manual, the area of use of the product must also comply with locally applicable safety, accident prevention and environmental protection specifications as well as those in the manual for the machine tool.

No modifications must be made to the product. The operator is wholly and solely responsible for any resultant personal injury and/or damage to materials.

2.2 Personnel requirements



WARNING

Serious injuries caused by incorrect handling of the product by insufficiently skilled or trained personnel!

- All activities must be performed by skilled staff from the relevant specialist field.



WARNING

Serious injuries caused by unauthorized presence of unauthorized personnel in the working area!

- Keep unauthorized people away from the working area.
- If in doubt, speak to people and direct them to leave the working area.
- Interrupt work until unauthorized people have left the working area.



NOTE

Serious damage to materials caused by incorrect handling of the product by insufficiently skilled or trained personnel!

- All activities must be performed by skilled staff from the relevant specialist field.

This manual name the following skills sets required for various different areas of activity:

Skilled specialist

Skilled specialists, due to their professional training, knowledge and experience and awareness of applicable provisions, are capable of carrying out the work entrusted to them and independently to identify and avoid potential hazards.

Specialist / empowered person for lifting gear and load handling equipment

A specialist is someone with sufficient knowledge of load handling equipment, obtained through vocational training and experience, and who is sufficiently familiar with the applicable government health & safety at work specifications and generally recognized technical regulations [e.g. BG rules, DIN standards, VDE stipulations, the technical regulations of other member states of the European Union or Turkey, or other contracting countries to the European Economic Area Treaty] to assess the safe working condition of load handling equipment.

Hydraulics specialist

Hydraulics specialists are trained in the specific task profile for which they are employed, and are familiar with the relevant standards and legislative provisions.

Due to their vocational training and experience, hydraulics specialists can work on hydraulic systems and can independently identify and avoid potential hazards.

Pneumatics specialist

Pneumatics specialists are trained in the specific task profile for which they are employed, and are familiar with the relevant standards and legislative provisions.

Due to their vocational training and experience, pneumatics specialists can work on pneumatic systems and can independently identify and avoid potential hazards.

Electricians

Electricians are trained in the specific task profile for which they are employed, and are familiar with the relevant standards and legislative provisions.

Due to their vocational training and experience, electricians can work on electrical systems and can independently identify and avoid potential hazards.

Trainees

Trainees can only work on the machine under the supervision and direction of staff skilled in the relevant specialist field.

The only people admitted as personnel are those who can reasonably be expected to carry out their work to a reliable standard. People whose response capabilities are impaired, for example by drugs, alcohol or medication, are prohibited.

For the selection of personnel, pay attention to the stipulations applicable at the place of work governing age and specific vocational requirements.

2.3 Intended use

The lifting equipment is intended for the installation / removal of clamping devices. It must not remain in the machine tool but must instead be removed before the start of machining.

The product is only intended for the type of use described in this manual [see »Use« chapter]. Furthermore, an extended form of use can be agreed contractually between manufacturer and operator.

Only skilled staff from the appropriate specialist fields may operate and clean the product [see »Personnel requirements« chapter].

Never exceed the technical values stipulated for the product [see »General information« and »Operating conditions« chapters].

Maintain the product at regular intervals [see »Maintenance schedule« chapter].

When used for its intended purpose, the operational safety of the product is assured, subject to compliance with relevant safety stipulations, to the full extent foreseeable.

Intended use also includes compliance with all stipulations in this manual.

Any form of use beyond the scope of intended use, or other forms of use of the product, is considered as misuse, and can lead to dangerous situations.



WARNING

Serious injuries caused by misuse of the product!

- Never use in a machine while it is operating.
- Only use for the type of use indicated [see »Use« chapter].
- Only skilled staff from the appropriate specialist fields may use the product [see »Personnel requirements« chapter].
- Never exceed the technical data indicated on the product [see »General information« and »Operating conditions« chapters].
- Maintain the product at regular intervals [see »Maintenance schedule« chapter].
- Only use with compatible products.
- Only use on products authorized by the manufacturer.



NOTE

Damage to materials caused by incorrect use of the product!

- Never use in a machine while it is operating.
- Only use for the type of use indicated [see »Use« chapter].
- Only skilled staff from the appropriate specialist fields may use the product [see »Personnel requirements« chapter].
- Never exceed the technical data indicated on the product [see »General information« and »Operating conditions« chapters].
- Maintain the product at regular intervals [see »Maintenance schedule« chapter].
- Only use with compatible products.
- Only use on products authorized by the manufacturer.

Claims of all kinds will be rejected that are due to unintended use.

Here are some examples of unintended use of the product

- If the lifting equipment is used on non-intended products;

2.4 Personal protective equipment

During work, it is essential to wear personal protective equipment to minimize the health hazards.

Always wear the required personal protective equipment when working on any given job.

Always pay attention to any notices about personal protective equipment displayed in the working area.

Always wear



When working, always wear the following items:

Workplace clothing

Workplace clothing should be close-fitting, with low tear-resistance, narrow cuffs and no protruding parts. It serves primarily to protect the wearer from coming into contact with moving machine parts. Do not wear rings, chains or other jewelry.

Safety footwear

To protect the wearer from any heavy items that may fall, and from losing their footing on slippery ground.



Protective goggles

To protect the eyes from projectile parts and liquid splashes.



Hair net

To protect long hair from getting snagged in rotating parts on the machine tool.

Additional personal protective equipment

When carrying out certain work, additional personal protective equipment is required. Separate reference is made to this in the individual chapters of this manual. The following section explains these additional items of personal protective equipment:



Protective gloves

To protect the hands from friction, chafing, stabbing or deeper injuries and from contact with hot surfaces.



Hard hat

To protect against falling and projectile parts and materials.

2.5 Particular hazards

The following section names residual risks resulting from the use of lifting equipment. In all cases, the residual risks detected during a risk assessment of the machine tool need to be named by the operator.

Pay attention to the safety instructions named here, as well as the warning notices in other chapters of these operating instructions to reduce the risk of health hazards and to prevent dangerous situations.

Improper use



WARNING

Serious injuries caused by dropping parts ejected when lifting equipment is used improperly!

- Do not exceed the maximum suspended load.
- Remove damaged lifting equipment immediately to prevent it from continuing to be used [see »Fault table« chapter].
- Before lifting a load, check to ensure that the ball locking pins are fully engaged.
- Only unfasten the ball locking pins if the product is secured by being placed on a secure base, or is fully installed on the machine adapter.

Tilting the bracket



CAUTION

Crushing injuries caused by improper tilting of the bracket!

- The bracket must only be unlocked to install the product on the machine adapter.
- Never place fingers in the operating range of the bracket when tilting the bracket.

2.6 Other safety instructions



WARNING

Serious head injuries caused by bending into the working area of the machine!

- Only ever bend into the working area of the machine if there are no cutting tools or sharp objects in it, or if these are covered.
- Never move body parts under parts in the working area of the machine with the potential to drop down.

2.7 Screws



WARNING

Serious injuries caused by accidental opening of the fixing screws!

- All fixing screws must not be opened.
- If in doubt, contact the manufacturer immediately to determine how best to proceed.

2.8 Functionality



WARNING

Serious injuries caused by severe contamination of the product!

- Always comply with the cleaning instructions and intervals [see »Cleaning« chapter].

2.9 Environmental protection



NOTE

Substantial damage to the environment can result from non-compliant handling or incorrect disposal of environmentally hazardous substances!

- If environmentally hazardous substances enter the environment accidentally, take immediate remedial action.
- If in doubt, notify the relevant municipal authorities about the incident.

The following environmentally hazardous substances are used:

Lubricants, auxiliary materials and operating fluids

Lubricants such as grease and oil can contain toxic substances. These must not enter the environment.

Dispose of environmentally hazardous substances properly [see »Disposal« chapter].

3 Technical data

3.1 General information

Size	Torsional angle [°]	Angle of locking ball pin [°]	Outside diameter [mm]	Adjustment travel [mm]	Weight [kg]	Maximum load [kg] WLL
S	30	120	224.0	90.0	8.0	60
M	30	120	320.0	90.0	17.0	130

Table 1: Technical data

3.2 Performance values



NOTE

Material damage to the products use and/or to the machine tool caused by exceeding the maximum performance values!

- Do not exceed the maximum performance values [see »General information« chapter].
- On all products used, do not exceed the lowest of the maximum performance values.



INFORMATION

Details of maximum performance values can be found on each product.

3.3 Operating conditions

Indication	Value	Unit
Ambient temperature range	15 - 40	°C
Humidity	≤ 80	%

Table 2: Operating conditions

3.4 Type designation

The type designation is on the product and it includes the following indications:

- Manufacturer
- Product designation
- ID number [marked with a # symbol]
- Build year
- Maximum suspended load [*kg*]
- Unladen weight [*kg*]
- CE marking

4 Layout and function

4.1 Overview and brief description

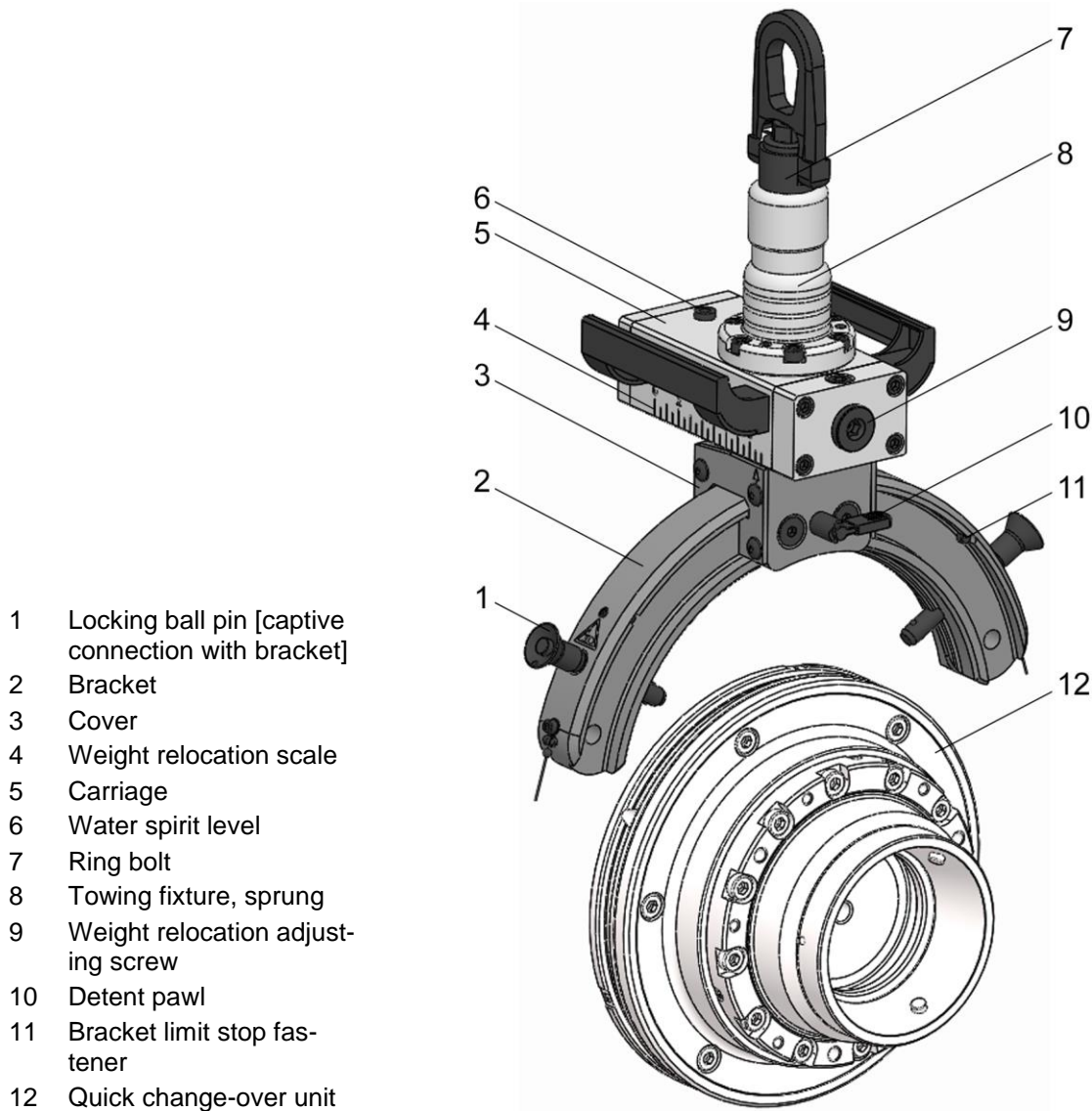

The lifting equipment is designed specifically for the installation of clamping devices with quick change-over adapters [quick change-over units].

All quick change-over units with appropriate locating geometry can be transported in this way.

With an adjusting screw, the quick change-over unit can be aligned horizontally until it is suspended above its center of gravity.

With the help of the tiltable holder, the quick change-over unit can be placed on the machine adapter of the quick change-over system.

5 Use and limits of use

5.1 Use

This product serves only to lift and centre HAINBUCH quick change-over units / quick change-over adapters in a horizontal orientation.

The product can only be used on a suitable quick change-over unit / a suitable quick change-over adapter from HAINBUCH.

As well as for its general field of application, this product was designed and developed for use, when necessary, in a specific and documented application [see clamping situation drawing or order confirmation].

Any other fields of application require the explicit approval of the manufacturer.

5.2 Limits of use

Limits are set on load handling equipment involved in the lifting and transporting of quick change-over units with load handling equipment.



DANGER

Serious injuries caused by dropping parts if the suspended load is outside permitted limits!

- Never exceed the maximum suspended load of the load handling equipment [see »General information« chapter].



NOTE

Damage to materials caused by unauthorized conversion of the bracket!

- It is prohibited to convert the unit to a different bracket.

6 Transport, packaging, storage

6.1 Safety, transport, packaging, storage



WARNING

High level of physical strain due to the weight of the product or of its components if not transported properly!

- From a weight of 10 kg, use appropriate transport equipment, lifting gear and lifting tackle.



WARNING

Serious crushing injuries and breakages caused by falling parts if transported incorrectly!

- Ensure that the product cannot roll away or fall.
- Place on a non-slip surface.
- When using lifting gear, use appropriate load-bearing equipment and lifting tackle.



WARNING

Serious injuries caused by transporting off-center equipment!

- Pay attention to marks on the packaging items.
- Attach the crane hook directly above the center of gravity.
- Raise carefully and correct the lifting points if necessary.



WARNING

Serious injuries caused by incorrect transport with lifting gear!

- Never raise loads above people.
- Never step under suspended loads.
- Pay attention to information about the intended lifting points. Ensure that the lifting gear is mounted on a secure base.
- Only use authorized and undamaged lifting gear, load-bearing equipment and lifting tackle.
- Never exceed the maximum load-bearing capacity of lifting gear, load-bearing equipment and lifting tackle.



NOTE

Damage to materials caused by falling parts if transported incorrectly!

- Ensure that the product cannot roll away or fall.
- Place on a non-slip surface.
- When using lifting gear, use appropriate load-bearing equipment and lifting tackle.

6.2 Symbols on the packaging



Fragile

Designates packaging items with fragile or breakable contents.

Handle the packaging item with care. Do not drop it and protect it against collision impacts.



Keep it dry

Keep packaging items dry and protect them from the ingress of water.



Position designation

Points to the correct upright position of the packaging item.

6.3 Transport inspection

Check the delivery on receipt immediately to ensure it is complete and has not been damaged in transit.

Proceed as follows if you find any externally visible signs of damage while in transit:

- Refuse to accept the delivery, or only subject to later approval
- Make a note of the extent of damage on the transportation documents or on the delivery note of the transportation company
- Initiate a complaint



INFORMATION

Raise a complaint for every defect as soon as it is discovered. Compensation claims can only be enforced during the applicable complaint periods.

6.4 Unpacking and internal transportation

The total weight of the product depends on its size.

1. The product is packaged in a stable position, and it has a ring bore for transportation.
2. Attach end-stop chain in the ring bolt and the crane hook.
3. Subject to weight, use lifting gear to lift the product out of its packaging safely, and place it down on a stable, flat surface.
4. Secure the product to prevent it from rolling away.
5. When transporting on a trolley or car, ensure that the product is securely mounted on a non-slip surface before starting to move it.

6.5 Packaging

The individual packaging items are packaged in an appropriate manner for the type of transportation involved. Always use environmentally compatible materials for packaging purposes.

Packaging should protect individual components from damage in transit, corrosion and other forms of damage, up until installation. For this reason, do not destroy the packaging, and do not remove it until shortly before installation.



INFORMATION

The packaging units are packaged, wrapped in airtight film and placed in cardboard boxes. On the individual weights of each of the sizes [see »General information« chapter].

Dispose of packaging material in accordance with applicable legislative provisions and local regulations.



NOTE

Damage to the environment caused by improper disposal of packaging materials!

- Dispose of packaging materials in an environmentally responsible manner.
- Pay attention to local disposal regulations and, if necessary, appoint a specialist waste disposal company with this work.

6.6 Storage



INFORMATION

The packaged items may display information relating to storage and readmission to storage that extend beyond the scope of these requirements. Pay attention to these notices.

Store packaged items under the following conditions:

- Safe for storage.
- Do not store outdoors.
- Store in a dry, dust-free place.
- Avoid exposure to aggressive media.
- Protect against direct sunlight.
- Avoid mechanical vibration.
- Storage temperature: 15 to 35°C.
- Relative humidity: Maximum 60%.
- In the event of storage for more than 3 months:
 - On a regular basis, check the general condition of all parts and packaging.
 - If necessary, refresh the preservation or replace it.

6.7 Preservation

1. Clean the product [see »Cleaning« chapter].
2. Apply a light coating of preserving oil to the inner and outer faces of the product. Wipe away surplus preserving oil with a sort, lint-free, tear-resistant cloth.
3. Pack product air-tight in foil.
4. Return product to storage [see »Return to storage« chapter].

6.8 Return to storage

Return product to storage under the following conditions:

1. Preserve the product [see »Preservation« chapter].
2. The product must be stored in a safe condition. Use an appropriate container for the product, on a non-slip surface, or fit the floor of the shelving unit with an all-round safety border.
3. For storage conditions, see the »Storage« chapter.

7 Use

7.1 Use-related safety



WARNING

Serious injuries caused by unskilled staff when using load handling equipment!

- Load handling equipment can only be operated by skilled staff from the relevant specialist field.



WARNING

Serious head injuries caused by bending into the working area of the machine!

- Only bend down into the working area of the machine if it contains no cutting tools or sharp objects, or if these are covered.
- Never move body parts under parts in the working area of the machine with the potential to drop down.



WARNING

Serious injuries when lifting a load caused by improper installation of the clamping device / quick change-over adapter!

- In addition to these operating instructions, you should also read and follow the operating instructions for the associated clamping device / quick change-over adapter.



WARNING

Serious injuries caused by failure to follow the commissioning procedure for the quick change-over system!

- In addition to these operating instructions, you should also read and follow the operating instructions for the associated machine adapter.



CAUTION

Serious crushing injuries caused by improper use of the Monteq unit!

- Never reach into the movement range of the bracket.

7.2 Preparation of machine for use

1. Set the machine into set-up mode.
2. Reduce the operating pressure to a minimum.
3. Remove cutting tools and/or sharp objects from the working area of the machine, or cover them.

7.3 Installation of the quick change-over unit

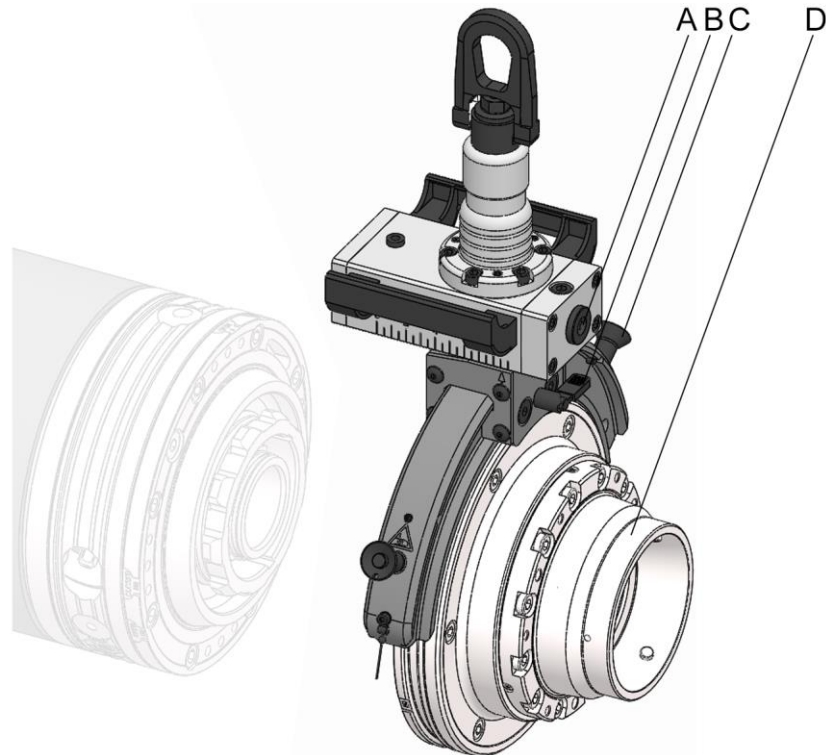

- A Weight relocation adjusting screw
- B Detent pawl
- C Locking ball pin
- D Quick change-over unit

1. As described in the »Preparing the machine for use« chapter, prepare for the following steps.
2. Install the clamping device for attaching to the lifting equipment.
3. Use a crane to pick up the lifting equipment.
4. With the help of the detent pawl, lock the center of the bracket.

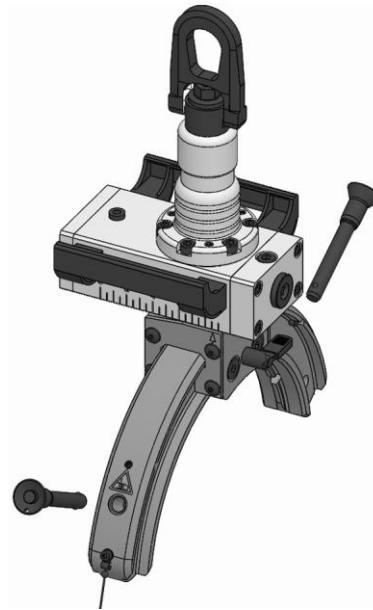

5. Remove the ball locking pin by actuating the relevant button on the face end.

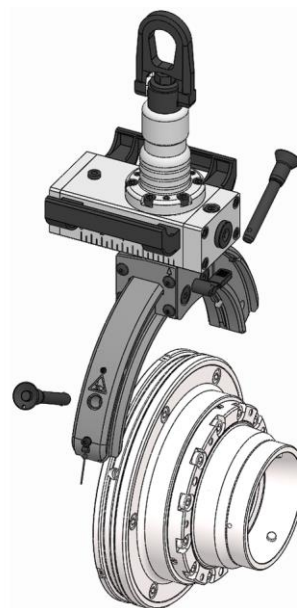
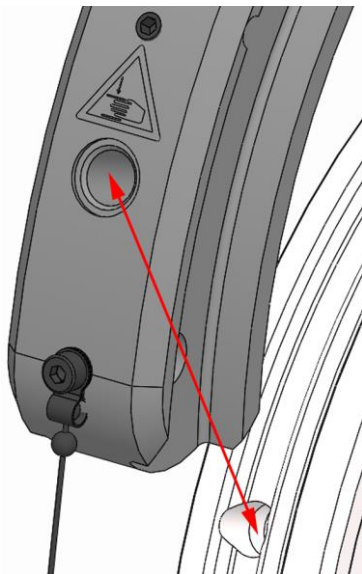

INFORMATION

Depending on the version of quick change-over adapter, its bores in the groove can be equipped with a spring-loaded protective cover.

6. Install the load-carrying equipment in the relevant groove of the quick change-over adapter so that the bores for the ball locking pins in the lifting equipment bracket are aligned with the bores in the groove of the quick change-over adapter.
7. Press and hold down the button of the ball locking pin and install firmly home until the locking ball pins engage in the bore of the quick change-over adapter.

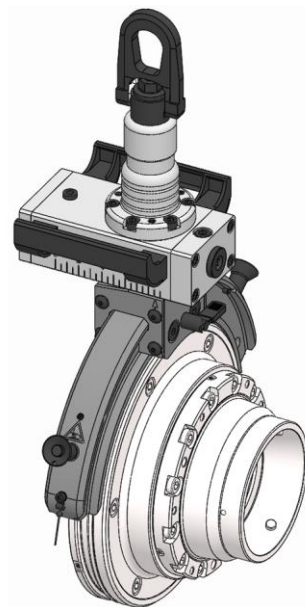

DANGER

Serious injuries caused by improper installation of the Monteq unit!

- Before lifting the load, check to ensure that the ball locking pins are engaged correctly.
- Ensure that only the quick change-over unit is being lifted.
- Do not exceed the maximum suspended load.

8. Raise the lifting equipment together with the quick change-over unit.

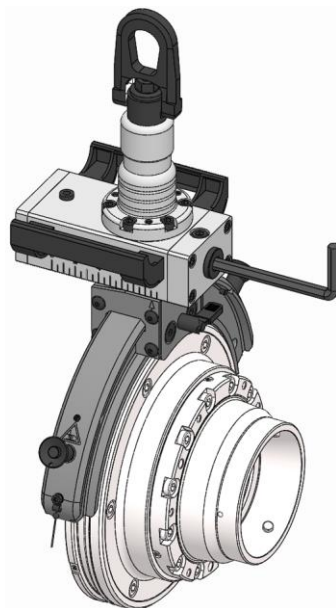

9. Align the combination horizontally with the help of the weight relocation adjusting screw and the water spirit level.



INFORMATION

Mark the position of the quick change-over unit for removal.



NOTE

Damage to materials caused by a defective end-stop on the machine adapter during installation / removal of the quick change-over unit!

- If the operating instructions for the quick change-over unit specify a different end-stop for the machine adapter than the one described below, compliance is mandatory.

10. Move the machine adapter to its front end-stop.

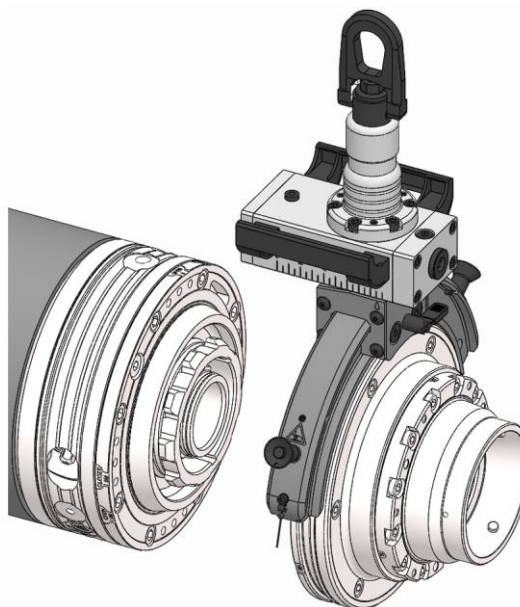

11. Use a crane to position the combination in front of the machine adapter.
12. With the help of the detent pawl, unlock the bracket directly beside the machine adapter.

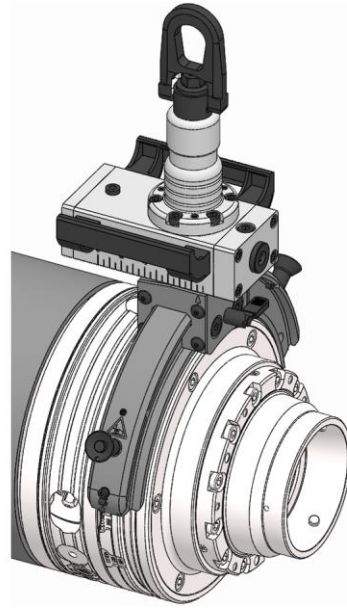

13. Fit the quick change-over unit to the machine adapter so that the mark on the quick change-over unit is aligned with the »OPEN« mark on the machine adapter.

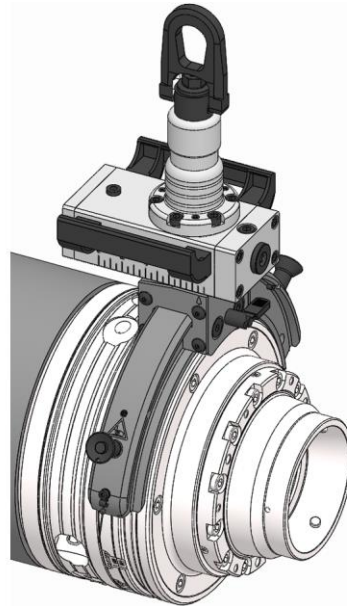

14. Twist the quick change-over unit to face the machine adapter so that the mark on the quick change-over unit is aligned with the »CLOSED« mark on the machine adapter.
15. If necessary, move the machine adapter to its rear end-stop.
16. Secure the quick change-over unit on the machine adapter [see operating instructions for the machine adapter].
17. Relieve load on the crane without unfastening the lifting equipment from the crane.

18. With the help of the detent pawl, lock the center of the bracket.

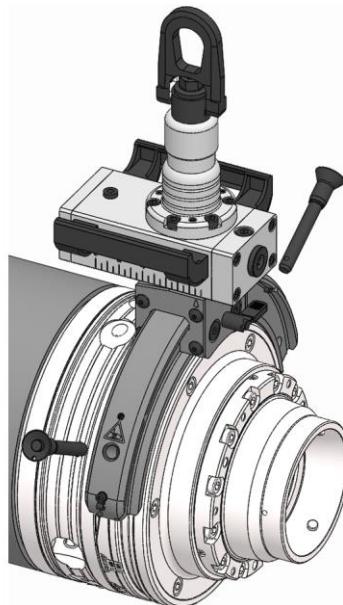

19. Remove the ball locking pin by actuating the relevant button on the face end.

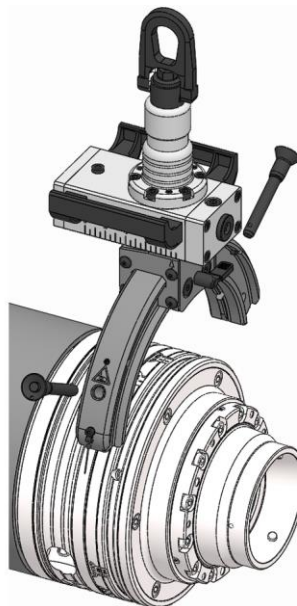

20. Remove the lifting gear from the clamping element and from the working area of the machine.



WARNING

Serious injuries caused by failure to follow the commissioning procedure for the clamping device!

- In addition to these operating instructions, you should also read and follow the operating instructions for the associated clamping device / quick change-over adapter.

7.4 Removal of the quick change-over unit

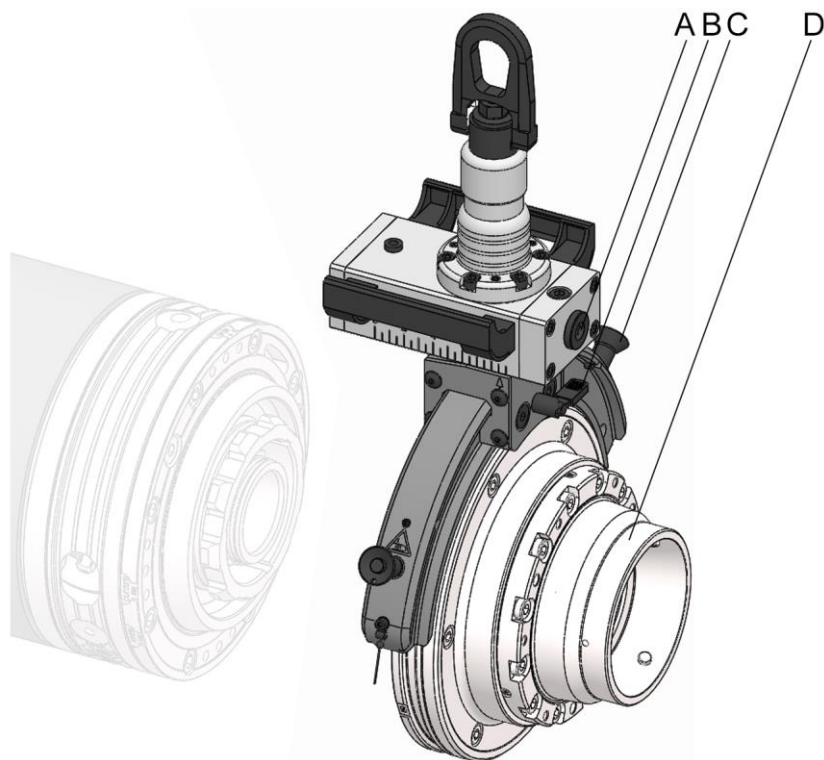

- A Weight relocation adjusting screw
- B Detent pawl
- C Locking ball pin
- D Quick change-over unit

1. As described in the »Preparing the machine for use« chapter, prepare for the following steps.
2. Move the machine adapter to its front end-stop.
3. Use a crane to pick up the lifting equipment.
4. With the help of the detent pawl, lock the center of the bracket.

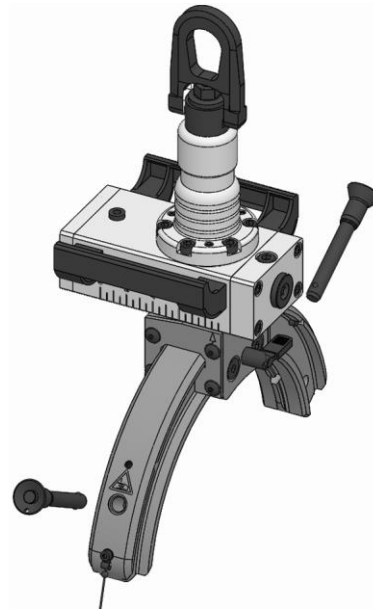

5. Remove the ball locking pin by actuating the relevant button on the face end.

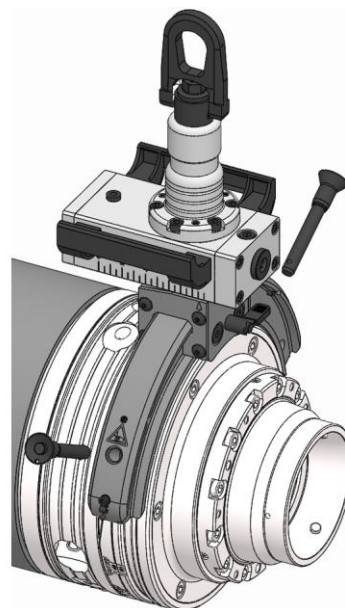
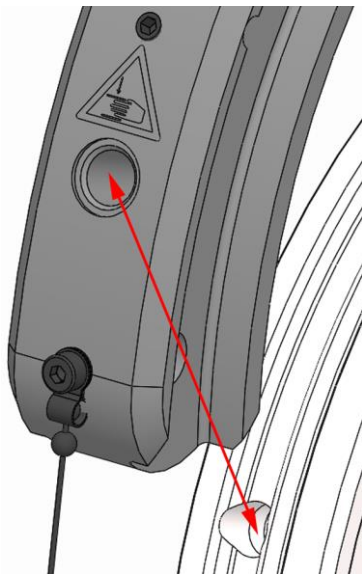

INFORMATION

Depending on the version of quick change-over adapter, its bores in the groove can be equipped with a spring-loaded protective cover.

6. Install the load-carrying equipment in the relevant groove of the quick change-over adapter so that the bores for the ball locking pins in the lifting equipment bracket are aligned with the bores in the groove of the quick change-over adapter.
7. Relieve load on the crane without unfastening the lifting equipment from the crane.

8. Press and hold down the button of the ball locking pin and install firmly home until the locking ball pins engage in the bore of the quick change-over adapter.



DANGER

Serious injuries caused by improper installation of the Monteq unit!

- Before lifting the load, check to ensure that the ball locking pins are engaged correctly.
 - Ensure that only the quick change-over unit is being lifted.
 - Do not exceed the maximum suspended load.
9. Use the crane to apply tension to the lifting equipment.
 10. Unfasten the mounting of the quick change-over unit on the machine adapter [see operating instructions for the machine adapter].
 11. With the help of the detent pawl, unlock the bracket.

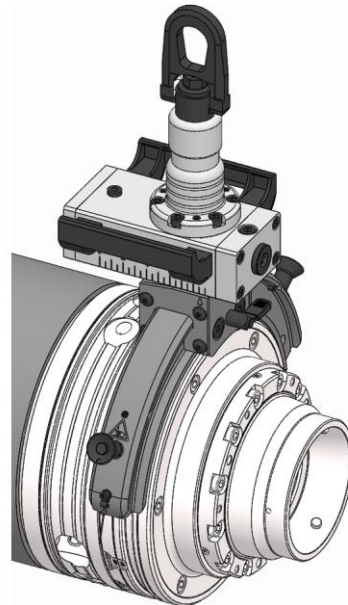

12. Twist the quick change-over unit to face the machine adapter so that the mark on the quick change-over unit is aligned with the »OPEN« mark on the machine adapter.

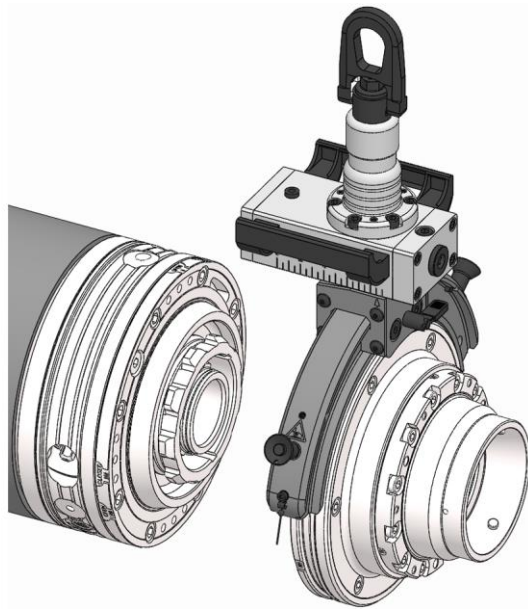

13. Disconnect the combination from the machine adapter.
14. With the help of the detent pawl, lock the center of the bracket.
15. Use the crane to move the combination to the storage location of the quick change-over unit and set down securely.

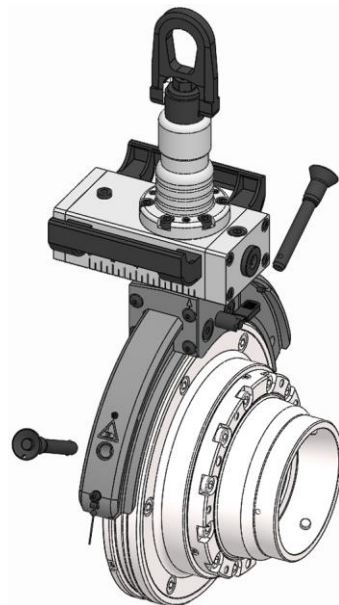

16. Remove the ball locking pin by actuating the relevant button on the face end.
17. Unfasten and remove the lifting gear.

7.5 Tests



NOTE

Serious damage to, or destruction of, the machine tool and the workpiece caused by damaged, incomplete or incorrectly installed products!

- Only install undamaged and complete products properly.
- If in doubt, contact the manufacturer.

7.6 Exceptional inspection

In the event of a collision, overload or other events that could affect load capacity, the load handling equipment must be subjected to an exceptional inspection by a specialist.

8 Maintenance

8.1 Maintenance safety



WARNING

Serious injuries caused by parts dropping!

- Maintain the inspection, maintenance and cleaning intervals of the product at all times.



WARNING

Serious injuries caused by the release of stored energy!

- The towing fixture must not be opened.
- All maintenance must be carried out by the manufacturer.



WARNING

Serious injuries caused by parts dropping if the sliding guides are worn!

- Only the manufacturer can replace worn sliding guides.



CAUTION

Health risks caused by incorrect handling of cleaning agents!

- Pay attention to hazard specifications and the safety data sheet of the manufacturer.

8.2 Maintenance schedule

The following sections describe the maintenance work needed to ensure optimum and fault-free operation.

Contact the manufacturer for questions relating to maintenance work and maintenance intervals [see »Contact« chapter].



WARNING

Serious injuries caused by non-compliant maintenance!

- All maintenance on the product must be carried out by the manufacturer.

8.3 Inspection

The operator must ensure that the product is inspected at regular, specified intervals by a qualified specialist.

To assure the lasting safety of the product, it must be inspected every six months.

During this inspection, the operating company must check and assure the following points:

- Operational capability / rolling capability of the rolling bearings
- Distortion of the locking ball pins
- Visible damage to components / cracks
- Seal lacquer points present and correct
- Spring function in balance
- Stopping function of the carriage
- Bracket does not scrape the cover [only Monteq S]

If one of these points is not satisfied, the product must be maintained by the manufacturer.

8.4 Cleaning



WARNING

Eye injuries and cuts caused by failure to wear protective clothing during cleaning operation!

- Never use compressed air to clean the product.
- Also wear the following items of personal protective equipment, in addition to the basic equipment:



NOTE

Damage to materials caused by incorrect Removal of the product!

- Never remove the product.



NOTE

Damage to seals caused by the wrong solvent!

- To clean the product, never use a solvent that attacks and damages the sealing elements installed. Those installed sealing elements can be made of NBR, Viton and PUR materials.
- To clean the product, never use a solvent that contains ester, nor a polar solvent.

1. Check the sliding guides for wear [only Monteq S].

2. Clean all surfaces on the product that can be accessed without disassembly, using an ester-free, non-polar cleaning agent and a soft, lint-free, tear-resistant cloth, wiping away all oil and grease residue and checking for visual signs of damage.

8.5 Visual inspection

Perform a daily visual inspection of the product to identify any damage to the product at an early stage.

Check the product for cracks and damage.

A check is also required to ensure that all fixing screws are tightened down.

If damage is detected, the relevant components must be exchanged immediately for genuine spare parts from the manufacturer.

Complete cleaning of the product is required if heavily soiled [see »Cleaning« chapter].

8.6 Lubricating the product

The product has lifetime lubrication and does not need to be relubricated by the operator.

9 Disposal

If no agreement exists for return or disposal, send dismantled components off for recycling.



NOTE

Substantial damage to the environment can result from incorrect disposal of environmentally hazardous substances!

- Lubricants, auxiliary materials and operating fluids are governed by legislation for the processing of special-category waste: All disposal to be performed by authorized waste disposal specialists.

Catch exchanged oils and greases in suitable containers and dispose of them in accordance with applicable local provisions.

The local municipal authority or specialist waste disposal companies can provide information about environmentally compliant disposal.

10 Faults

The following chapter describes possible causes for faults, and the work involved in remedial action.

Contact the manufacturer if faults occur that cannot be remedied by following these instructions [see »Contact« chapter].

10.1 Procedure with faults

This applies in all cases:

1. With faults that constitute an immediate danger to people or materials, press the Emergency Stop button on the machine tool and the crane immediately.
2. Establish the cause of the fault.
3. If troubleshooting requires work to be conducted in the danger area, switch the machine tool into set-up mode.
4. Notify the person on location of the fault immediately.
5. Depending on the type of fault, get it remedied by authorized and appropriately skilled specialists.



INFORMATION

The troubleshooting table in the following section provides information about who is authorized to remedy a given fault.

6. In the event of a fault not caused by the product, the fault may be caused by something close to the machine tool. For this, refer to the operating instructions of the machine tool.

10.2 Fault table

Fault	Possible cause	Remedial action	Remedied by
The bracket is difficult to move	Dirt in the bracket groove [bearing race]	Clean the lifting gear	Skilled specialist
	Dirt in the bearings of the carriage	Clean the bearings	HAINBUCH
Unlocking/locking of the ball locking pins does not function	Dirt or defect of internal mechanism of the locking ball pins	Replace the locking ball pins	HAINBUCH
	Crane load not relieved	Relieve load on crane	Skilled specialist
Bracket scrapes the cover [only Monteq S]	Wear on the sliding guide	Replacement of the sliding guide	HAINBUCH

Table 3: Fault table

10.3 Commissioning after a fault has been remedied

After the fault has been remedied, perform the following steps to recommission it:

1. Reset the emergency stop equipment.
2. Acknowledge the fault on the control unit of the machine tool.
3. Ensure that no-one is in the danger area.
4. Start the machine tool.

11 Annex

11.1 Contact

The following hotlines are available to you for orders, schedule tracking and emergencies.

Order hotline

Ordered quickly, supplied swiftly. Just phone:

+49 7144. 907-333

Tracking hotline

Current status of your order? Just call:

+49 7144. 907-222

24 hour emergency phone line

Has a system crash occurred, or some other technical emergency?

Our experts are there for you around the clock:

+49 7144. 907-444

For advice or help, you can contact the sales partners and service staff listed in www.hainbuch.com.

11.2 Conformity declaration

The conformity declaration is supplied with the product and with its manual.

Index directory

B		Hydraulics specialist	11
Brief description	19	Pneumatics specialist	11
C		Skilled specialist.....	11
Cleaning.....	38	Trainees	11
Copyright	8	Preservation	24
D		Protective equipment	
Definition of terms	7	Hair net	14
E		Hard hat	14
Environmental protection	16	Protective gloves.....	14
Exceptional inspection	36	Protective goggles	14
F		Safety footwear	13
Fault table	42	Workplace clothing.....	13
Faults	41	R	
H		Removal	
Hazards	14	Quick change-over unit	32
I		S	
Inspection	38	Safety	
Installation		General	10
Quick change-over unit.....	26	Maintenance	37
Intended use	12	Transport, packaging, storage	21
K		Use	25
Key to symbols.....	6	Scope of delivery.....	8
L		Spare parts.....	9
Layout	19	Storage.....	24
Liability.....	8	Symbols on the packaging	22
Limits of use.....	20	T	
Lubricants	16	Technical data.....	17
M		Tests	36
Maintenance schedule	37	Transport inspection.....	22
Misuse	12	Transportation, internal	23
O		Type designation.....	18
Operating conditions	17	U	
P		Unpacking	23
Packaging	23	Use.....	20
Performance values	17	Preparation of machine	26
Personnel requirements.....	10	W	
Electricians	11	Warranty.....	9



HAINBUCH GMBH · SPANNENDE TECHNIK

Postfach 1262 · 71667 Marbach / Erdmannhäuser Strasse 57 · 71672 Marbach · Germany

Tel. +49 7144.907-0 · Fax +49 7144.18826 · verkauf@hainbuch.de · www.hainbuch.com

24 hour emergency phone line + 49 7144.907-444